

# FLM HD20

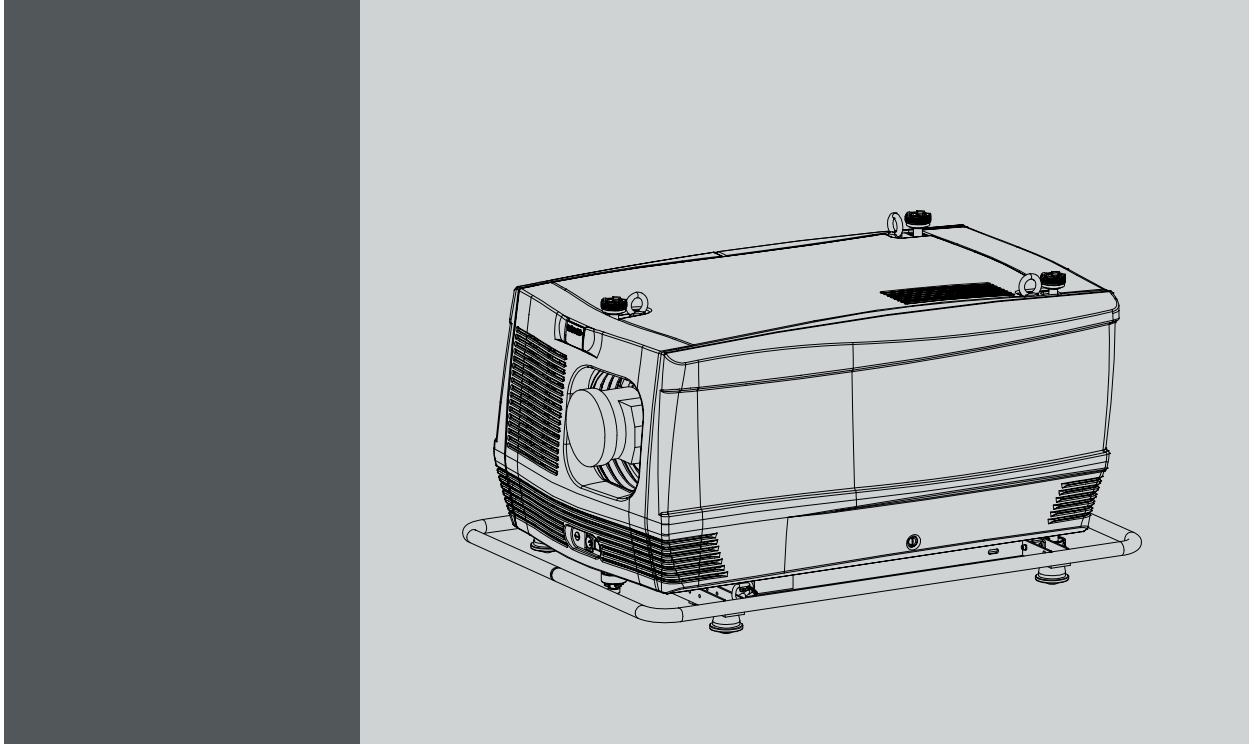

## User guide

**Barco nv Media & Entertainment Division**

Noordlaan 5, B-8520 Kuurne

Phone: +32 56.36.82.11

Fax: +32 56.36.883.86

E-mail: [sales.events@barco.com](mailto:sales.events@barco.com)

Visit us at the web: [www.barco.com](http://www.barco.com)

## Changes

Barco provides this manual 'as is' without warranty of any kind, either expressed or implied, including but not limited to the implied warranties or merchantability and fitness for a particular purpose. Barco may make improvements and/or changes to the product(s) and/or the program(s) described in this publication at any time without notice.

This publication could contain technical inaccuracies or typographical errors. Changes are periodically made to the information in this publication; these changes are incorporated in new editions of this publication.

## Copyright ©

All rights reserved. No part of this document may be copied, reproduced or translated. It shall not otherwise be recorded, transmitted or stored in a retrieval system without the prior written consent of Barco.

## Trademarks

Brand and product names mentioned in this manual may be trademarks, registered trademarks or copyrights of their respective holders. All brand and product names mentioned in this manual serve as comments or examples and are not to be understood as advertising for the products or their manufacturers.

## Federal Communications Commission (FCC Statement)

This equipment has been tested and found to comply with the limits for a class A digital device, pursuant to Part 15 of the FCC rules. These limits are designed to provide reasonable protection against harmful interference when the equipment is operated in a commercial environment. This equipment generates, uses, and can radiate radio frequency energy and, if not installed and used in accordance with the instruction manual, may cause harmful interference to radio communications. Operation of this equipment in a residential area may cause harmful interference, in which case the user will be responsible for correcting any interference at his own expense

## EN55022/CISPR22 Class A ITE (Information Technology Equipment)

Class A ITE is a category of all other ITE which satisfies the class A ITE limits but not the class B ITE limits. Such equipment should not be restricted in its sale but the following warning shall be included in the instructions for use:

**Warning :** This is a class A product. In a domestic environment this product may cause radio interference in which case the user may be required to take adequate measures.

## Software License Agreement

You should carefully read the following terms and conditions before using this software. Your use of this software indicates your acceptance of this license agreement and warranty.

### Terms and Conditions:

1. No redistribution of the software is allowed.
2. Reverse-Engineering. You may not reverse engineer, decompile, disassemble or alter anyhow this software product.

### Disclaimer of Warranty:

This software and the accompanying files are sold "as is" and without warranties as to performance or merchantability or any other warranties whether expressed or implied. In no event shall Barco be liable for damage of any kind, loss of data, loss of profits, business interruption or other pecuniary loss arising directly or indirectly. Any liability of the seller will be exclusively limited to replacement of the product or refund of purchase price.

## GNU-GPL code

If you would like a copy of the GPL source code contained in this product shipped to you on CD, please contact Barco. The cost of preparing and mailing a CD will be charged.

## Disposal Information

This equipment has required the extraction and use of natural resources for its production. It may contain hazardous substances for health and environment. In order to avoid the dissemination of those substances in the environment and to diminish the pressure on natural resources, we encourage you to use the appropriate take-back systems. Those systems will reuse or recycle most of the materials of your end of life equipment in a sound way.



The crossed-out wheeled bin symbol invites you to use those systems. If you need more information on the collection, reuse and recycling systems, please contact your local or regional waste administrator. You can also contact us for more information on the environmental performances of our products.



# TABLE OF CONTENTS

|  |           |
|--|-----------|
| <b>1. Safety</b>   | <b>5</b>  |
| 1.1 General  | 5         |
| 1.2 Important safety instructions                            | 6         |
| 1.3 Important warnings concerning FLM flight cases           | 9         |
| <b>2. General</b>  | <b>11</b> |
| 2.1 Installation requirements                                | 11        |
| 2.2 Unpacking the projector                                  | 12        |
| 2.3 Box content  | 13        |
| 2.4 FLM flight case  | 14        |
| 2.5 Projector configurations                                 | 14        |
| 2.6 Projector air inlets and outlets                         | 18        |
| 2.7 Free download of Projector Toolset                       | 18        |
| <b>3. Physical installation</b>                              | <b>19</b> |
| 3.1 Remote control unit (RCU)                                | 19        |
| 3.1.1 RCU battery installation                               | 20        |
| 3.1.2 RCU rugged case installation                           | 21        |
| 3.1.3 RCU XLR adaptor installation                           | 21        |
| 3.1.4 Using the XLR adaptor of the RCU                       | 21        |
| 3.1.5 RCU usage possibilities                                | 22        |
| 3.2 Lenses   | 23        |
| 3.2.1 Available lenses                                       | 23        |
| 3.2.2 Lens selection   | 23        |
| 3.2.3 Lens formulas  | 24        |
| 3.2.4 Lens installation                                      | 24        |
| 3.2.5 Lens removal   | 26        |
| 3.3 Alignment of a table mount FLM projector                 | 27        |
| 3.4 Alignment of a ceiling mount FLM projector               | 27        |
| 3.5 Suspension of the FLM projector with rigging clamps      | 28        |
| <b>4. Stacking FLM projectors</b>                            | <b>31</b> |
| 4.1 Stacking FLM projectors                                  | 31        |
| 4.2 Aligning stacked FLM projectors                          | 33        |
| <b>5. Connections</b>  | <b>35</b> |
| 5.1 Power connection   | 35        |
| 5.2 Input source connections                                 | 37        |
| 5.3 Communication connections                                | 38        |
| <b>6. Getting started</b>                                    | <b>43</b> |
| 6.1 RCU & Local keypad                                       | 43        |
| 6.2 Terminology overview                                     | 43        |
| 6.3 Operating the projector                                  | 45        |
| 6.3.1 Switching on   | 45        |
| 6.3.2 Errors, warnings and messages during start up          | 46        |
| 6.3.3 Switching to standby                                   | 46        |
| 6.3.4 Switching off  | 47        |
| 6.4 Using the RCU  | 47        |
| 6.5 Quick setup adjustments                                  | 49        |
| 6.5.1 Text boxes ON or OFF                                   | 49        |
| 6.5.2 Quick Lens Adjustment                                  | 49        |
| 6.5.2.1 Quick Lens Adjustment via LENS key                   | 49        |
| 6.5.2.2 Direct Lens Adjustment (RCU)                         | 50        |
| 6.5.3 Quick picture in picture                               | 50        |
| 6.5.4 Quick layout selection with Rigging key                | 51        |
| 6.5.5 Quick language selection                               | 51        |
| 6.6 Projector address  | 52        |
| 6.6.1 Displaying and Programming addresses                   | 52        |
| 6.6.2 Controlling the projector                              | 53        |
| 6.7 Source selection   | 53        |
| 6.8 Controlling the Projector                                | 54        |
| <b>7. Start up of the Adjustment Mode</b>                    | <b>55</b> |
| 7.1 About the adjustment mode                                | 55        |
| 7.2 About the use of the remote control and the local keypad | 55        |
| 7.3 Start up the adjustment mode                             | 55        |
| 7.4 Navigation and adjustments                               | 56        |
| 7.5 On screen menus versus LCD display menus                 | 56        |
| 7.6 Test patterns in adjustment mode                         | 57        |
| 7.7 Menu memory  | 57        |

|  |            |
|--|------------|
| <b>8. Input menu</b>                         | <b>59</b>  |
| 8.1 Overview flow                            | 59         |
| 8.2 Slot module type                         | 59         |
| 8.2.1 About Input Setup                      | 59         |
| 8.2.2 Input configuration                    | 60         |
| 8.3 Input locking                            | 61         |
| 8.4 Minimum delay                            | 63         |
| 8.5 Native resolution                        | 63         |
| 8.6 Source switching                         | 65         |
| 8.7 No signal                                | 65         |
| 8.7.1 Background color                       | 66         |
| 8.7.2 Shutdown setting                       | 66         |
| 8.7.3 Shutdown retarding time                | 66         |
| <b>9. Image menu</b>                         | <b>69</b>  |
| 9.1 Overview flow                            | 69         |
| 9.2 How to select the image adjustments?     | 70         |
| 9.3 Image Settings                           | 70         |
| 9.3.1 Contrast                               | 71         |
| 9.3.2 Brightness                             | 71         |
| 9.3.3 Saturation                             | 72         |
| 9.3.4 Tint (hue)                             | 73         |
| 9.3.5 Phase                                  | 73         |
| 9.3.6 Sharpness                              | 74         |
| 9.3.7 Noise reduction                        | 75         |
| 9.3.8 Color temperature                      | 76         |
| 9.3.8.1 Predefined color temperature         | 76         |
| 9.3.8.2 Set a custom color temperature       | 77         |
| 9.3.9 Input balance                          | 78         |
| 9.3.9.1 Introduction to Input Balance        | 78         |
| 9.3.9.2 Adjusting the input balance          | 79         |
| 9.4 Aspect ratio                             | 82         |
| 9.5 Timings                                  | 83         |
| 9.5.1 Source timings                         | 83         |
| 9.5.2 Advanced settings                      | 84         |
| 9.5.3 Advanced settings, film mode detection | 86         |
| 9.6 Image files services                     | 87         |
| 9.6.1 Files and file manipulations           | 87         |
| 9.6.2 Manual Load file                       | 88         |
| 9.6.3 Delete file                            | 89         |
| 9.6.4 Delete all custom files                | 89         |
| 9.6.5 Rename a file                          | 90         |
| 9.6.6 Copy a file                            | 91         |
| 9.6.7 File options                           | 91         |
| 9.7 Save custom settings                     | 92         |
| <b>10. Layout menu</b>                       | <b>95</b>  |
| 10.1 Overview flow                           | 95         |
| 10.2 Main window                             | 95         |
| 10.2.1 Source selection                      | 96         |
| 10.2.2 Size adjustment                       | 96         |
| 10.2.3 Position adjustment                   | 99         |
| 10.3 PIP window                              | 100        |
| 10.3.1 Introduction to PIP                   | 100        |
| 10.3.2 Picture in Picture activation         | 101        |
| 10.3.3 Picture in Picture source selection   | 101        |
| 10.3.4 Picture in Picture size of the window | 102        |
| 10.3.5 Picture in Picture, position window   | 105        |
| 10.4 Layout file services                    | 106        |
| 10.4.1 Load layout                           | 106        |
| 10.4.2 Rename a layout                       | 107        |
| 10.4.3 Delete a layout                       | 107        |
| 10.4.4 Copy / Save as a layout               | 108        |
| 10.5 Zoom - Focus                            | 109        |
| <b>11. Lamp menu</b>                         | <b>111</b> |
| 11.1 Overview flow                           | 111        |
| 11.2 Lamp power mode                         | 111        |
| 11.3 Lamp power                              | 112        |
| 11.4 Lamp Identification                     | 113        |
| 11.5 Z-axis adjustment                       | 113        |
| <b>12. Alignment menu</b>                    | <b>115</b> |
| 12.1 Overview flow                           | 115        |
| 12.2 Orientation                             | 116        |
| 12.3 Lens adjustment                         | 117        |
| 12.4 Side keystone                           | 118        |

|            |   |            |
|------------|---|------------|
| 12.5       | Warp geometry settings .....                        | 119        |
| 12.5.1     | About Warp geometry settings .....                  | 119        |
| 12.5.2     | Warp Status .....                                   | 120        |
| 12.5.3     | Horizontal keystone correction .....                | 121        |
| 12.5.4     | Vertical keystone correction .....                  | 122        |
| 12.5.5     | Rotation .....                                      | 123        |
| 12.5.6     | Pincushion - Barrel correction .....                | 124        |
| 12.5.7     | 4 corner correction .....                           | 125        |
| 12.5.8     | Reset warp settings .....                           | 126        |
| 12.5.9     | Load warp file .....                                | 127        |
| 12.6       | Contrast enhancement .....                          | 128        |
| 12.7       | Blanking .....                                      | 128        |
| 12.8       | Gamma .....   | 130        |
| 12.9       | Internal pattern .....                              | 130        |
| 12.10      | Color space .....                                   | 131        |
| 12.11      | ScenergiX .....                                     | 132        |
| 12.11.1    | Introduction .....                                  | 132        |
| 12.11.2    | Preparations .....                                  | 133        |
| 12.11.3    | ScenergiX activation .....                          | 133        |
| 12.11.4    | ScenergiX overlap zone (horizontal ScenergiX) ..... | 134        |
| 12.11.5    | ScenergiX overlap zone (vertical ScenergiX) .....   | 135        |
| 12.11.6    | ScenergiX size adjustment (White level) .....       | 137        |
| 12.11.7    | Adjusting the black level of the images .....       | 139        |
| <b>13.</b> | <b>Projector control .....</b>                      | <b>143</b> |
| 13.1       | Overview flow .....                                 | 143        |
| 13.2       | Projector address .....                             | 144        |
| 13.2.1     | Individual projector address .....                  | 144        |
| 13.2.2     | Common address .....                                | 145        |
| 13.3       | Serial communication .....                          | 146        |
| 13.3.1     | Baud rate setup .....                               | 146        |
| 13.3.2     | Interface standard .....                            | 146        |
| 13.3.3     | RS422 termination .....                             | 147        |
| 13.4       | Network .....                                       | 147        |
| 13.4.1     | Introduction to a Network connection .....          | 148        |
| 13.4.2     | DHCP setup .....                                    | 148        |
| 13.4.3     | IP-address set up .....                             | 149        |
| 13.4.4     | Subnet-mask set up .....                            | 149        |
| 13.4.5     | Default Gateway set up .....                        | 150        |
| 13.5       | IR control switching .....                          | 151        |
| 13.6       | Art-Net DMX .....                                   | 151        |
| 13.6.1     | DMX address .....                                   | 152        |
| 13.6.2     | DMX universe .....                                  | 152        |
| 13.6.3     | DMX monitor .....                                   | 153        |
| 13.6.4     | DMX mode .....                                      | 154        |
| 13.6.5     | Art-Net activation .....                            | 155        |
| 13.6.6     | Home lens at startup .....                          | 155        |
| 13.7       | Buttons .....                                       | 156        |
| 13.7.1     | Standby button .....                                | 156        |
| 13.7.2     | APA (auto) button .....                             | 157        |
| 13.7.3     | Shortcut keys .....                                 | 157        |
| 13.8       | Menu position .....                                 | 158        |
| 13.8.1     | On screen menu .....                                | 158        |
| 13.8.2     | Bar scale .....                                     | 159        |
| 13.9       | Local LCD .....                                     | 159        |
| 13.9.1     | Local LCD time out .....                            | 159        |
| 13.9.2     | Local LCD contrast .....                            | 160        |
| 13.10      | Language selection .....                            | 160        |
| <b>14.</b> | <b>Service menu .....</b>                           | <b>163</b> |
| 14.1       | Overview flow .....                                 | 163        |
| 14.2       | Identification .....                                | 163        |
| 14.3       | Diagnosis .....                                     | 165        |
| 14.3.1     | How to start up the diagnosis? .....                | 165        |
| 14.3.2     | Versions .....                                      | 165        |
| 14.3.3     | Voltages .....                                      | 166        |
| 14.3.4     | I <sup>2</sup> C diagnosis .....                    | 167        |
| 14.3.5     | Temperatures .....                                  | 167        |
| 14.3.6     | Fan speeds overview .....                           | 168        |
| 14.3.7     | SPI .....   | 169        |
| 14.3.8     | Error logging overview .....                        | 170        |
| 14.4       | Convergence .....                                   | 170        |
| 14.5       | Internal service patterns .....                     | 171        |
| 14.6       | Restore factory defaults .....                      | 172        |
| 14.7       | Reset formatter .....                               | 173        |
| 14.8       | Save custom settings .....                          | 174        |

|  |            |
|--|------------|
| 14.9 Refill mode .....   | 174        |
| 14.10 Broadcast mode .....                                     | 175        |
| 14.11 USB memory .....   | 176        |
| <b>15. Maintenance .....</b>                                   | <b>179</b> |
| 15.1 Replacement of the dust filter on the front side .....    | 179        |
| 15.2 Replacement of the dust filter on the bottom side .....   | 180        |
| 15.3 Replacement of the dust filter on the top side .....      | 181        |
| 15.4 Pressure verification of the liquid cooling circuit ..... | 181        |
| 15.5 Cleaning the lens .....                                   | 182        |
| 15.6 Cleaning the exterior of the projector .....              | 182        |
| <b>16. Servicing .....</b>                                     | <b>183</b> |
| 16.1 Removal of the lamp house .....                           | 183        |
| 16.2 Removal of the input & communication unit .....           | 184        |
| 16.3 Removal of an input module .....                          | 185        |
| 16.4 Installation of the lamp house .....                      | 186        |
| 16.5 Installation of the input & communication unit .....      | 187        |
| 16.6 Installation of an input module .....                     | 188        |
| 16.7 Realignment of the lamp in its reflector .....            | 189        |
| <b>17. Removal of the projector covers .....</b>               | <b>191</b> |
| 17.1 Removal of the front cover .....                          | 191        |
| 17.2 Removal of the side cover .....                           | 192        |
| 17.3 Removal of the lamp cover .....                           | 193        |
| 17.4 Removal of the input cover .....                          | 193        |
| 17.5 Installation of the front cover .....                     | 194        |
| 17.6 Installation of the side cover .....                      | 195        |
| 17.7 Installation of the lamp cover .....                      | 196        |
| 17.8 Installation of the input cover .....                     | 197        |
| <b>18. Dimensions .....</b>                                    | <b>199</b> |
| 18.1 Dimensions of the FLM HD20 .....                          | 199        |
| 18.2 Dimensions of the FLM flight case .....                   | 200        |
| 18.3 Dimensions of the rigging clamps .....                    | 201        |
| <b>19. Standard Source Files .....</b>                         | <b>203</b> |
| 19.1 Table overview .....                                      | 203        |
| <b>20. DMX chart .....</b>                                     | <b>205</b> |
| 20.1 DMX chart, basic .....                                    | 205        |
| 20.2 DMX chart, Extended .....                                 | 206        |
| 20.3 DMX chart, Full .....                                     | 207        |
| <b>21. Troubleshooting .....</b>                               | <b>211</b> |
| 21.1 Error codes .....   | 211        |
| <b>22. Specifications .....</b>                                | <b>219</b> |
| 22.1 Specifications FLM HD20 .....                             | 219        |
| 22.2 Specifications FLM 5 cable input (multi purpose) .....    | 222        |
| 22.3 Specifications FLM HDSDI – SDI input .....                | 223        |
| 22.4 Specifications FLM DVI input .....                        | 224        |
| 22.5 Specifications FLM DVI HDCP input .....                   | 225        |
| <b>23. Order information .....</b>                             | <b>227</b> |
| 23.1 Spare part order info .....                               | 227        |
| <b>Glossary .....</b>  | <b>229</b> |
| <b>Index .....</b>   | <b>231</b> |

# 1. SAFETY

## 1.1 General



**WARNING:** Ensure you understand and follow all the safety guidelines, safety instructions, warnings and cautions mentioned in this manual.



**WARNING:** Be aware of suspended loads.



**WARNING:** Wear a hard hat to reduce the risk of personal injury.



**WARNING:** Be careful while working with heavy loads.



**WARNING:** Mind your fingers while working with heavy loads.



**CAUTION:** High pressure lamp may explode if improperly handled.

### Notice on safety

This equipment is built in accordance with the requirements of the international safety standards IEC60950-1, EN60950-1, UL60950-1 and CAN/CSA C22.2 No.60950-1, which are the safety standards of information technology equipment including electrical business equipment. These safety standards impose important requirements on the use of safety critical components, materials and insulation, in order to protect the user or operator against risk of electric shock and energy hazard, and having access to live parts. Safety standards also impose limits to the internal and external temperature rises, radiation levels, mechanical stability and strength, enclosure construction and protection against the risk of fire. Simulated single fault condition testing ensures the safety of the equipment to the user even when the equipment's normal operation fails.

### Restricted access location

The FLM HD20 must be installed in a restricted access location, due to the temperature rise of parts of the equipment (air outlet).



#### Restricted access location

A location for equipment where both of the following paragraphs apply:

- 1) Access can only be gained by SERVICE PERSONS or by USERS who have been instructed about the reasons for the restriction applied to the location and about the precautions that shall be taken.
- 2) Access is through the use of the tool or lock and key, or other means of security, and is controlled by the authority responsible for the location.

## 1.2 Important safety instructions

---

### To prevent the risk of electrical shock

- This product should be operated from a mono phase AC power source. Power input voltage range must be between 200-240 VAC, 50/60Hz, 20 amps at 230 VAC.
- The power cord of the FLM HD20 is equipped with a 3-wire grounding plug, a plug having a third (grounding) pin. This plug will only fit into a grounding-type IEC 60309 power outlet. This is a safety feature. Mains power cord with IEC 60309 plug:



**Warning:** This apparatus must be grounded (earthed) via the supplied 3 conductor AC power cable. If the supplied power cable is not the correct one, consult your dealer.

If you are unable to insert the plug into the outlet, contact your electrician to replace your obsolete outlet with respect to the local regulations. Do not defeat the purpose of the grounding-type plug.

- Do not allow anything to rest on the power cord. Do not locate this product where persons will walk on the cord. To disconnect the cord, pull it out by the plug. Never pull the cord itself.
- If an extension cord is used with this product, make sure that the total of the ampere ratings on the products plugged into the extension cord does not exceed the extension cord ampere rating.
- Use only the power cord supplied with your device. While appearing to be similar, other power cords have not been safety tested at the factory and may not be used to power the device. For a replacement power cord, contact your dealer.
- Never push objects of any kind into this product through cabinet slots as they may touch dangerous voltage points or short out parts that could result in a risk of fire or electrical shock.
- Never spill liquid of any kind on the product. Should any liquid or solid object fall into the cabinet, unplug the set and have it checked by qualified service personnel before resuming operations.
- Lightning - For added protection for this video product during a lightning storm, or when it is left unattended and unused for long periods of time, unplug it from the wall outlet. This will prevent damage to the device due to lightning and AC power-line surges.

## To prevent personal injury

- Isolated electrically before re-lamping. Caution : hot lamp (house).
- Caution: High pressure lamp may explode if improperly handled. Refer servicing to qualified service personnel. The customer should never attempt to disassemble the lamp casing or to dispose of the lamp casing other than by returning it to Barco.
- To reduce the lamp heat of the projector, switch the projector first to standby and let the projector lamp cool down for at least 5 minutes. Then the projector may be switched off with the power switch.
- To prevent injury and physical damage, always read this manual and all labels on the system before inserting the lamp casing, connecting to the wall outlet or adjusting the projector.
- To prevent injury, take note of the weight of the projector. Minimum 4 persons are needed to carry the FLM HD20.
- To prevent injury, ensure that the lens and all cover plates are correctly installed. See installation procedures.
- Warning: high intensity light beam. NEVER look into the lens ! High luminance could result in injury to the eye.
- Before attempting to remove any of the projector's covers, you must disconnect from the wall outlet.
- When performing setup work to a ceiling mounted projector, to prevent injury caused by falling objects or the system, set out a keep out area.
- Consult a professional structural engineer prior to suspending the projector from a structure not intended for that use. Always ensure that the working load limit of the structure can handle the load of the projector.
- Never stack more than two (2) FLM projectors in a hanging configuration (truss) and never stack more than three (3) FLM projectors in a base stand configuration (table mount).
- The power input at the projector side is considered as the disconnect device. When required to switch off the device, to access parts inside, always disconnect the power cord at the base of the device. In case the power input at the base of the device is not accessible (e.g. ceiling mount), the socket outlet supplying the device shall be installed nearby the device and be easily accessible, or a readily accessible general disconnect device shall be incorporated in the fixed wiring.
- Do not place this equipment on an unstable cart, stand, or table. The product may fall, causing serious damage to it and possible injury to the user.
- When mounting the device to the ceiling or to a rigging system, always mount security chains.
- It is hazardous to operate without lens or shield. Shields, lenses or ultra-violet screens shall be changed if they have become visible damaged to such an extent that their effectiveness is impaired. For example by cracks or deep scratches.
- **Warning: Protection from ultraviolet radiation:** Do not look directly in the light beam. The lamp contained in this product is an intense source of light and heat. One component of the light emitted from this lamp is ultraviolet light. Potential eye and skin hazards are present when the lamp is energized due to ultraviolet radiation. Avoid unnecessary exposure. Protect yourself and your employees by making them aware of the hazards and how to protect themselves. Protecting the skin can be accomplished by wearing tightly woven garments and gloves. Protecting the eyes from UV can be accomplished by wearing safety glasses that are designed to provide UV protection. In addition to the UV, the visible light from the lamp is intense and should also be considered when choosing protective eye wear.
- **Exposure to UV radiation:** Some medications are known to make individuals extra sensitive to UV radiation. The American Conference of Governmental Industrial Hygienists (ACGIH) recommends occupational UV exposure for an 8-hour day to be less than 0.1 microwatts per square centimeters of effective UV radiation. An evaluation of the workplace is advised to assure employees are not exposed to cumulative radiation levels exceeding these government guidelines.
- **Cooling liquid circuit.** The device head contains a cooling circuit filled with Blue antifreeze diluted (1/3 ethanediol – 2/3 Demi water).  
When the cooling circuit leaks, switch off the device and contact a service technician.  
The liquid is not for household use. Keep out of reach of children. Harmful by oral intake. Avoid exposure to pregnant women. Avoid contact with eyes, skin and clothing. Avoid inhale of the noxious fumes.

## To prevent device damage

- The FLM HD20 has been designed for use with a specific lamp (house) type. See installation instructions for its correct type.
- If the air filters are not regularly replaced, the air flow inside the projector could be disrupted, causing overheating. Overheating may lead to the projector shutting down during operation.
- In order to ensure that correct airflow is maintained, and that the device complies with electromagnetic compatibility (EMC) requirements, and for safety requirements, it should always be operated with all of its covers in place.
- Slots and openings in the cabinet are provided for ventilation. To ensure reliable operation of the product and to protect it from overheating, these openings must not be blocked or covered. The openings should never be blocked by placing the product on a bed, sofa, rug, or other similar surface. This product should never be placed near or over a radiator or heat register. The device should not be placed in a built-in installation or enclosure unless proper ventilation is provided.
- Do not block the projector cooling fans or free air movement under and around the projector. Loose papers or other objects may not be nearer to the projector than 10 cm (4") on any side.
- The device must always be mounted in a manner which ensures free flow of air into its air inlets and unimpeded evacuation of the hot air exhausted from its cooling system. Heat sensitive materials should not be placed in the path of the exhausted air. Leave at least a free safety area of 1 meter (40") at the rear of the projector.
- Ensure that nothing can be spilled on, or dropped inside the projector. If this does happen, switch off and unplug the mains supply immediately. Do not operate the projector again until it has been checked by qualified service technicians.
- Consult a professional structural engineer when you have the intention to use this projector as ceiling mounted projector. Always ensure the working load limit of the structure supporting the projector.
- Do not use this equipment near water.

- **Special Care for Laser Beams:** Special care should be used when DLP projectors are used in the same room as high power laser equipment. Direct or indirect hitting of a laser beam on to the lens can severely damage the Digital Mirror Devices™ in which case there is a loss of warranty.
- Never place a FLM HD20 in direct sun light. Sun light on the lens can severely damage the Digital Mirror Devices™ in which case there is a loss of warranty.
- Save the original packing material; they will come in handy if you ever have to ship your equipment. For maximum protection, repack your set as it was originally packed at the factory.
- Unplug this product from the wall outlet before cleaning. Do not use liquid cleaners or aerosol cleaners. Use a damp cloth for cleaning. Never use strong solvents, such as thinner or benzine, or abrasive cleaners, since these will damage the cabinet. Stubborn stains may be removed with a cloth lightly dampened with mild detergent solution.
- To ensure the highest optical performance and resolution, the projection lenses are specially treated with an anti-reflective coating, therefore, avoid touching the lens. To remove dust on the lens, use a soft dry cloth. Do not use a damp cloth, detergent solution, or thinner.
- Rated maximum ambient temperature,  $t_a = 40\text{ °C}$  (104°F).
- The lamp house shall be replaced if it has become damaged or thermally deformed.

### To prevent battery explosion

- Danger of explosion if battery is incorrectly installed.
- Replace only with the same or equivalent type recommended by the manufacturer.
- Dispose of used batteries according to the manufacturer's instruction.

### To prevent fire hazard

- Warning "Risk of fire". Do not place flammable or combustible materials near the projector !  
This projector radiates heat on its external surfaces and from ventilation ducts during normal operation, which is both normal and safe. Exposing flammable or combustible materials into close proximity of this projector could result in the spontaneous ignition of that material, resulting in a fire. For this reason, it is absolutely necessary to leave an "exclusion zone" around all external surfaces of the projector whereby no flammable or combustible materials are present. The exclusion zone must be not less than 40 cm (18"). The exclusion zone on the lens side must be at least 2 m (80").
- Do not cover the projector or the lens with any material while the projector is in operation.
- Mount the device in a well ventilated area away from sources of ignition and out of direct sun light.
- Never expose the projector to rain or moisture.
- In the event of fire, use sand, CO<sub>2</sub>, or dry powder fire extinguishers; never use water on an electrical fire.
- This product should never be placed near or over a radiator or heat register.
- This projector should not be placed in a built-in installation or enclosure unless proper ventilation is provided.
- The operation room must be well ventilated or cooled in order to avoid build up of heat.

### On servicing

- Do not attempt to service this product yourself, as opening or removing covers may expose you to dangerous voltage potentials and risk of electric shock.
- Refer all servicing to qualified service personnel.
- Fence off a restricted area of at least 3 meters around the projector using an eye-catching fence and "KEEP OUT" signs. This to prevent unauthorized persons coming near the projector during servicing.
- Unplug this product from the wall outlet and refer servicing to qualified service technicians under the following conditions:
  - When the power cord or plug is damaged or frayed.
  - If liquid has been spilled into the equipment.
  - If the product has been exposed to rain or water.
  - If the product does not operate normally when the operating instructions are followed. Adjust only those controls that are covered by the operating instructions since improper adjustment of the other controls may result in damage and will often require extensive work by a qualified technician to restore the product to normal operation.
  - If the product has been dropped or the cabinet has been damaged.
  - If the product exhibits a distinct change in performance, indicating a need for service.
- Replacement parts: When replacement parts are required, be sure the service technician has used original Barco replacement parts. Unauthorized substitutions may result in degraded performance and reliability, fire, electric shock or other hazards. Unauthorized substitutions may void warranty.
- Safety check: Upon completion of any service or repairs to this device, ask the service technician to perform safety checks to determine that the product is in proper operating condition.
- Lamp replacement: high pressure lamp may explode if improperly handled.



## 1.3 Important warnings concerning FLM flight cases

---

### Important warnings concerning stacking/transporting FLM rental flight cases

- Stack maximum two (2) FLM rental flight cases high. Never higher.
- Surface on which flight case is standing must be level to ensure that the total load is evenly spread out among the four wheels. The surface must also be able to support the load safely.
- Before stacking or transporting flight cases, check the wheels and their fixation screws for wear or defects.
- Before stacking or transporting flight cases, check that the four lock handles on each flight case are in good working order and locked securely.
- When stacked, make sure the wheels of the upper flight case are precisely positioned in the stacking dishes of the flight case below.
- Stacked flight cases may not be moved. Before stacking, the lower flight case must already be in its final resting position before placing the second upon it.
- Never stack loaded flight cases in a truck or other transport medium, unless each flight case is rigidly strapped tight.
- In the event of a wheel breaking, flight cases must be rigidly strapped tight to prevent a stack collapsing.
- Use an appropriate forklift to raise flight cases and take the necessary precautions to avoid personnel injury.



---

## 2. GENERAL

### About this chapter

Read this chapter before installing your FLM HD20. It contains important information concerning installation requirements for the FLM HD20, such as minimum and maximum allowed ambient temperature, humidity conditions, required safety area around the installed projector, required power net, compatible signal sources, etc.

Furthermore, careful consideration of things such as image size, ambient light level, projector placement and type of screen to use are critical to the optimum use of the projection system.

### Overview

- Installation requirements
- Unpacking the projector
- Box content
- FLM flight case
- Projector configurations
- Projector air inlets and outlets
- Free download of Projector Toolset

---

## 2.1 Installation requirements

### Ambient temperature conditions

The maximum allowed ambient temperature for an operating Barco FLM HD20 may not exceed +40 °C (+104 °F).

The minimum allowed ambient temperature for an operating Barco FLM HD20 may not drop below +10 °C (+50 °F).

The projector will not operate if the ambient air temperature falls outside this range (+10 °C → +40 °C or +50 °F → +104 °F). Be aware that room heat rises to the ceiling. Check if the temperature near the installation site is not excessive.

The minimum storage temperature is -35 °C (-31 °F) and the maximum storage temperature is +65 °C (+149 °F).

### Humidity conditions

Storage: 0 to 98% relative humidity, non-condensing.

Operation: 0 to 95% relative humidity, non-condensing.

### Projector weight

Do not underestimate the weight of one Barco FLM HD20, which is about ±100 kg (±225 lb.). Be sure that the table or truss installation on which the projector(s) has to be installed is capable of handling five (5) times the complete load of the complete system.

### Power requirements

One Barco FLM HD20 requires 200-240 VAC, 50/60Hz, 20 amps at 230 VAC.

### Clean air environment

A projector must always be mounted in a manner which ensures the free flow of clean air into the projectors ventilation inlets. For installations in environments where the projector is subject to airborne contaminants such as that produced by smoke machines or similar (these deposit a thin layer of greasy residue upon the projectors internal optics and imaging electronic surfaces, degrading performance), then it is highly advisable and desirable to have this contamination removed prior to it reaching the projectors clean air supply. Devices or structures to extract or shield contaminated air well away from the projector are a prerequisite, if this is not a feasible solution then measures to relocate the projector to a clean air environment should be considered.

Only ever use the manufacturer's recommended cleaning kit which has been specifically designed for cleaning optical parts, never use industrial strength cleaners on the projector's optics as these will degrade optical coatings and damage sensitive optoelectronics components. Failure to take suitable precautions to protect the projector from the effects of persistent and prolonged air contaminants will culminate in extensive and irreversible ingrained optical damage. At this stage cleaning of the internal optical units will be noneffective and impracticable. Damage of this nature is under no circumstances covered under the manufacturer's warranty and may deem the warranty null and void. In such a case the client shall be held solely responsible for all costs incurred during any repair. It is the clients responsibility to ensure at all times that the projector is protected from the harmful effects of hostile airborne particles in the environment of the projector. The manufacturer reserves the right to refuse repair if a projector has been subject to knowingly neglect, abandon or improper use.

### Which screen type ?

There are two major categories of screens used for projection equipment. Those used for front projected images and those for rear projection applications.

Screens are rated by how much light they reflect (or transmit in the case of rear projection systems) given a determined amount of light projected toward them. The 'GAIN' of a screen is the term used. Front and rear screens are both rated in terms of gain. The gain of screens range from a white matte screen with a gain of 1 (x 1) to a brushed aluminized screen with a gain of 10 (x 10) or more. The choice between higher and lower gain screens is largely a matter of personal preference and another consideration called the viewing angle. In considering the type of screen to choose, determine where the viewers will be located and go for the highest gain screen possible. A high gain screen will provide a brighter picture but reduce the viewing angle. For more information about screens, contact your local screen supplier.

### What image size? How big should the image be?

The projector is designed for projecting an image size : minimum 1 meter (3.3 ft.) to maximum 18 meter (59 ft.) (depending on the ambient light conditions), with an aspect ratio of 16 to 9 (recommended between 1 m (3.3ft) - 12 m (39.4ft)).

## 2.2 Unpacking the projector

### What has to be done ?

At delivery the projector is packed in a carton box upon a wooden pallet and secured with banding and fastening clips. Furthermore, to provide protection during transportation, the projector is surrounded with foam. Once the projector is arrived at the installation site, it has to be removed from the carton box and wooden pallet in a safe manner without damaging the projector.

### Necessary tools

- Side cutter.
- 8 mm Allen key.

### How to unpack the projector ?

1. Remove the banding around the carton box, by releasing the fastening clips as illustrated, and remove the top cover.

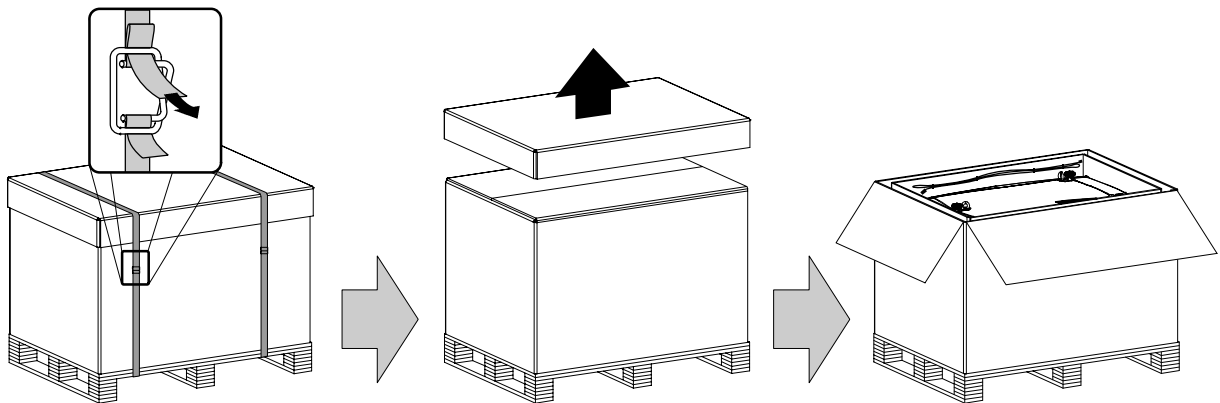

Image 2-1

2. Remove the power cord, which is attached to the packaging with a cable ties, and the two smaller carton boxes, located between the inner carton sleeve and outer carton box.

**Note:** The two smaller carton boxes contain the manuals, the remote control unit (RCU), two standard batteries size AA and four rigging clamps for projector suspension.

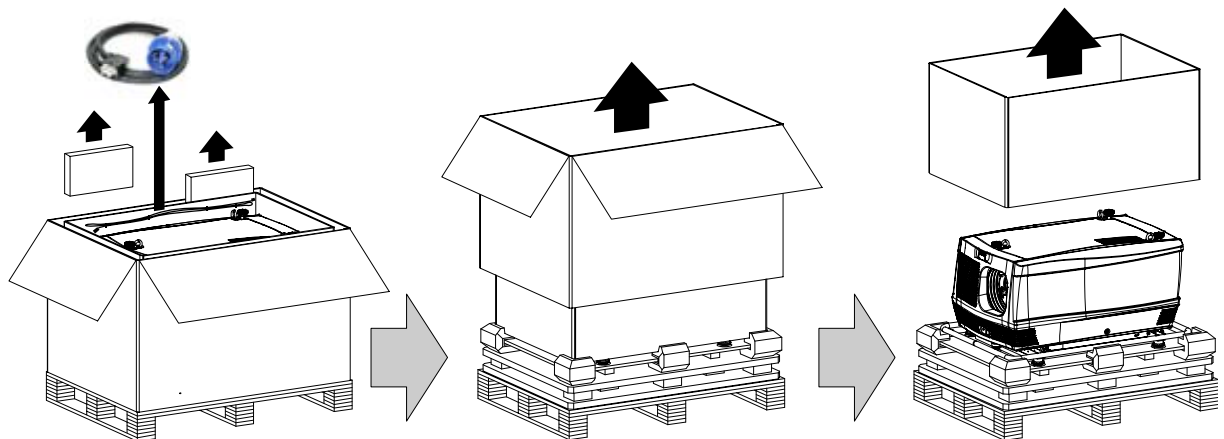

Image 2-2

- Remove the carton box, the inner carton sleeve and the foam around the projector. See image 2-2.

**Note:** The projector is still attached to a wooden plate, which is detached from the below pallet.

- Gently turn the projector upside down to gain access to the four bolts, which secure the projector. Note that this wooden plate is detached from the pallet.

**Tip:** Lay a blanket (or the earlier removed foam) on the floor to protect the projector housing from scratches while turning.

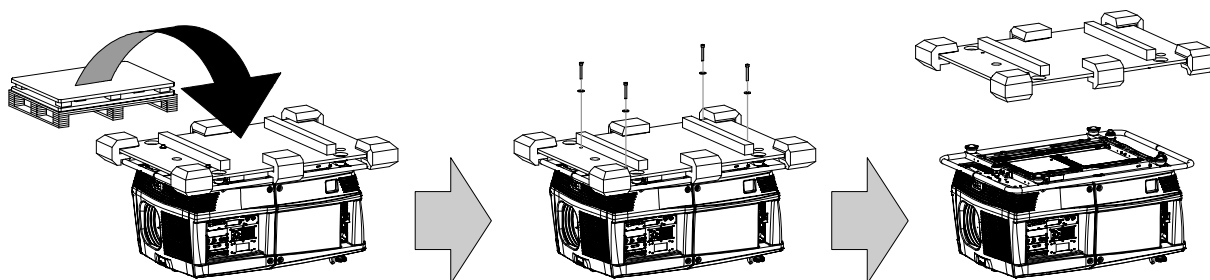

Image 2-3

- Remove the wooden plate from the projector bottom, by releasing the four bolts. Use an 8 mm Allen key. See image 2-3.
- Gently turn the projector back on its feet.
- Remove the foam rubber around the carrying handle.



**Save the original shipping carton and packing material, they will be necessary if you ever have to ship your projector. For maximum protection, repack your projector as it was originally packed at the factory.**



**A rubber foam inside a plastic bag is placed into the lens opening of the projector. It's recommended to reuse this foam and plastic back each time you transport the projector. This to prevent intrusion of dust and foreign particles.**

## 2.3 Box content

### Content

- One Barco FLM HD20, weight  $\pm 100$  kg ( $\pm 225$  lb.).
- One Remote Control Unit (RCU).
- Two AA size batteries for the RCU.
- One power cord of 2,5 meter with EN60-309 plug.
- Four rigging clamps for projector suspension.
- One user manual.

### Initial inspection

Before shipment, the projector was inspected and found to be free of mechanical and electrical defects. As soon as the projector is unpacked, inspect for any damage that may have occurred in transit. Save all packing material until the inspection is completed. If damaged is found, file claim with carrier immediately. The Barco sales and service office should be notified as soon as possible.



**The packaging of the FLM HD20 is provided with a shock-watch label. If this shock-watch label was triggered (red colored at arrival) during transport, indicates that the package was possibly roughly handled by the transport company. In this case, the instructions mentioned on the label, should be followed, which are: adding a note on the "bill of lading" and informing the transport company and the Barco sales and service office as soon as possible.**

### Mechanical check

This check should confirm that there are no broken knobs or connectors, that the cabinet and panel surfaces are free of dents and scratches, and that the meter face and operating panel are not scratched or cracked. The Barco sales and service office should be notified as soon as possible.

## 2.4 FLM flight case

### Introduction of the FLM flight case

The FLM flight case is designed to transport the FLM HD20 in a safe and secure manner. The four caster wheels, provided with breaks, and the eight handles make the FLM flight case easy to handle. The floor of the flight case wagon is equipped with two small covered compartments to store the remote control and the rigging clamps. Furthermore, three Velcro strips are attached to the bottom for fastening the power cord of the projector.

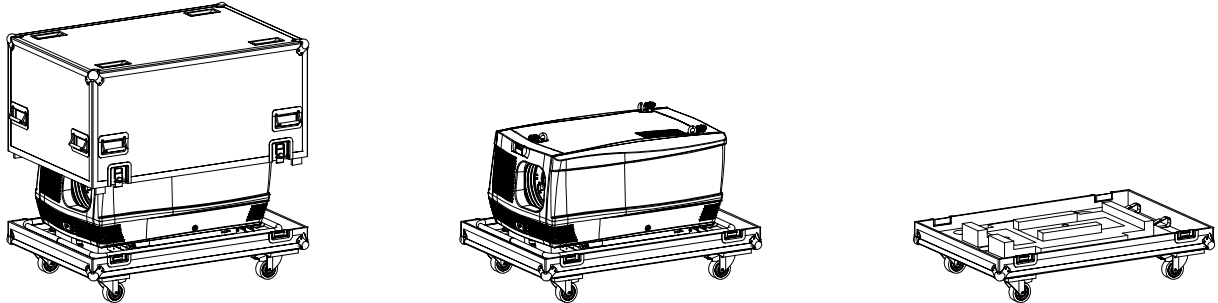

Image 2-4  
FLM flight case (R9854510).

The dimensions of the FLM flight case are optimal for maximum utilization of the floor area of a truck. The cover of the FLM flight case has four stacking dishes, which allows to stack the flight cases.

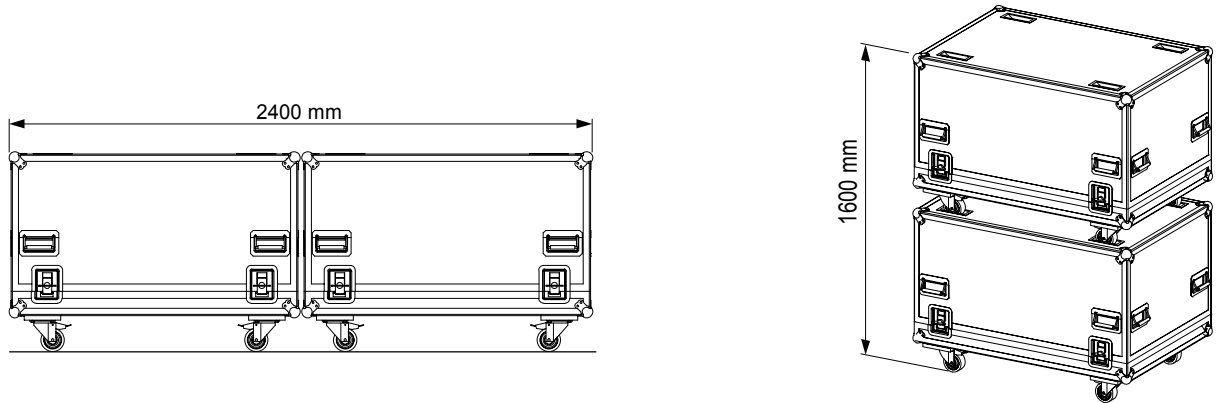

Image 2-5



**WARNING:** Maximum stack two (2) FLM flight cases high. Never higher.



**CAUTION:** Prior to inserting projector in flight case turn in the adjustable feet and interlocking adapters fully.

## 2.5 Projector configurations

### The different configurations

Depending on the installation the projector can be mounted in different ways, the 4 different configurations are:

1. Front / Table (F/T)
2. Front / Ceiling (F/C)
3. Rear / Table (R/T)
4. Rear / Ceiling (R/C)

### Front projection

The projector is installed, either in a table mount or ceiling mount configuration, at the same side of the screen as the audience.

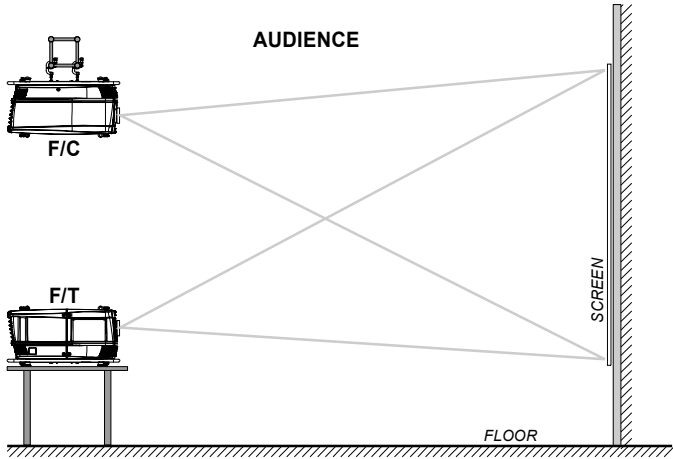

Image 2-6

**Rear projection**

The projector is installed, either in a table mount or ceiling mount configuration, at the other side of the screen opposite the audience.

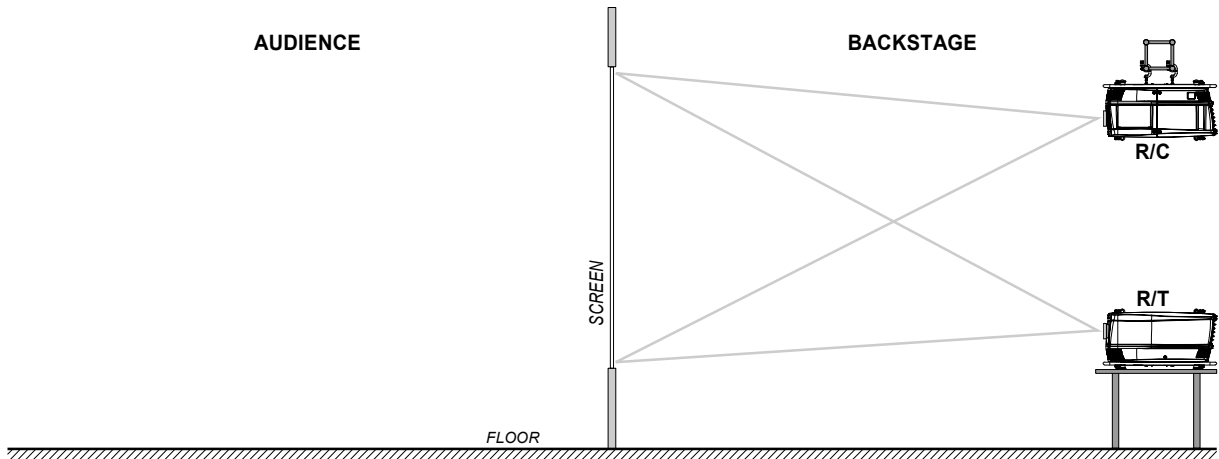

Image 2-7

### Positioning the projector

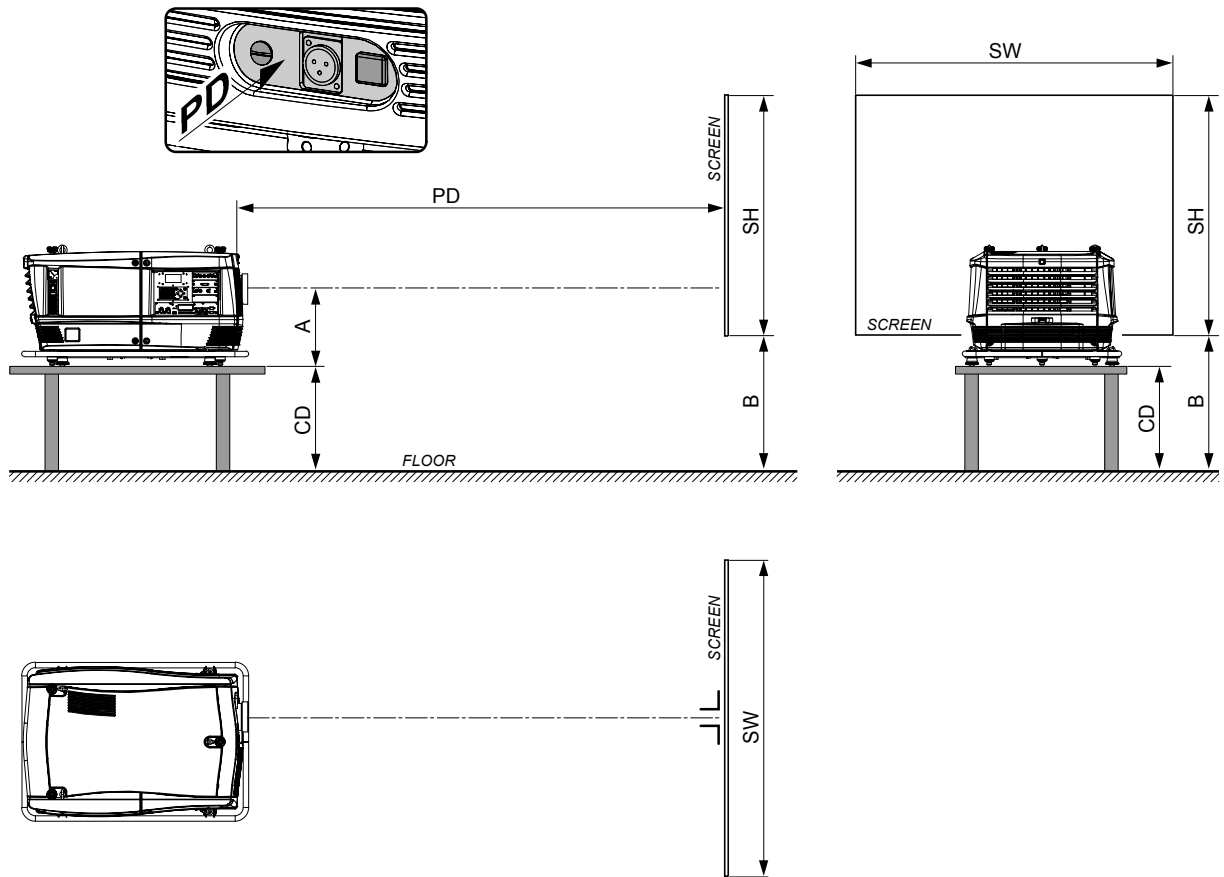

Image 2-8

The projector should be installed at right angles (horizontally and vertically) to the screen at a distance PD. Note the distance (A) between lens centre and table surface is slightly variable. This distance (A) is nominal 35 cm in case all feet are turned in completely and the vertical lens shift is set to zero (0).

### On-Axis / Off-Axis projection

The position of the projector with reference to the screen may also be different depending on the installation. Basically the projector can be positioned in On-Axis or Off-Axis configuration. On-Axis configuration means that the projector is positioned so as to have the centre of the lens coinciding with the centre of the screen. Off-Axis projection is obtained by shifting the lens up, down, left or right. Several parameters can be calculated determining the position in any installation.

Formula to calculate the distance CD for On-Axis projection:  $CD = SH/2 + B - A$

### Shift range

The lens can be shifted with respect to the DMD (P) which result in a shifted image on the screen (Off-Axis). A 100% shift means that the centre point of the projected image is shifted by half the screen size. In other words, the centre point of the projected image falls together with the outline of the image in an On-Axis projection. Due to mechanical and optical limitations it's recommended to keep the shift values within the field of view (F) as illustrated below. Within these shift ranges the projector and lens perform excellently. Configuring the projector outside these shift ranges will result in a slight decline of image quality.



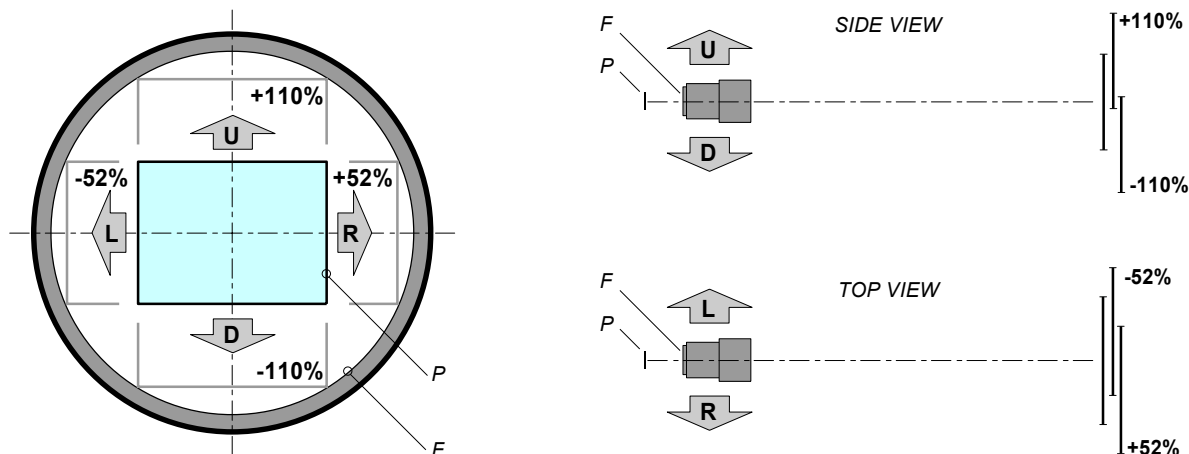

Image 2-9  
 P DMD.  
 F Field of view.



It's mechanical possible to shift outside the recommended field of view ( $\pm 120\%$  UP/DOWN and  $\pm 70\%$  LEFT/RIGHT), but this will result in a slightly decline of image quality depending on the used lens and the zoom position of the used lens. Furthermore, shifting too much in both directions will result in a blurred image corner.



Best image quality is projected in the On-Axis configuration.

### Horizontal and vertical projector tilt ranges

The projector can be rotated and mounted at any vertical angle. In other words, you can tilt the lens side of the projector as much as desired for your application. Side to side tilt, however, must not exceed  $\pm 15^\circ$ . This limit ensures that the lamp in the projector operates properly and safely. More tilting within area C is allowed but lamp flicker can happen.

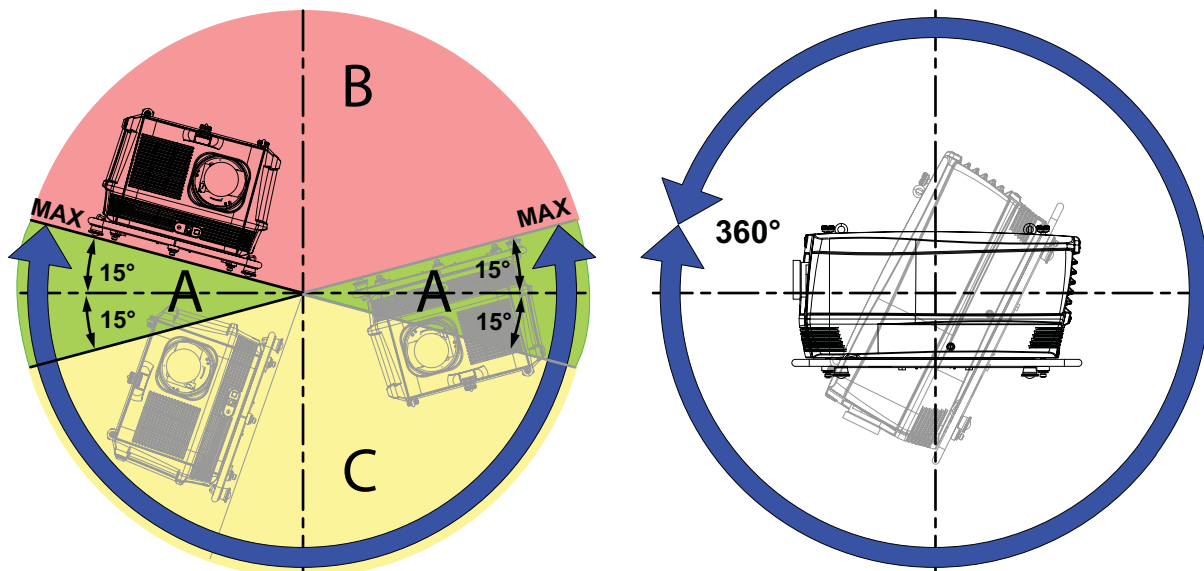

Image 2-10  
 A Tilting allowed without problems  
 B No tilting allowed in this area  
 C Tilting allowed but lamp flicker possible



**CAUTION:** Always respect the allowed tilt range of the projector. Neglecting this will result in lamp flicker, which reduces the light output and the life span of the lamp substantially. Furthermore, in the long term, the possibility exist that the lamp explodes.

## 2.6 Projector air inlets and outlets

### Air inlets and outlets

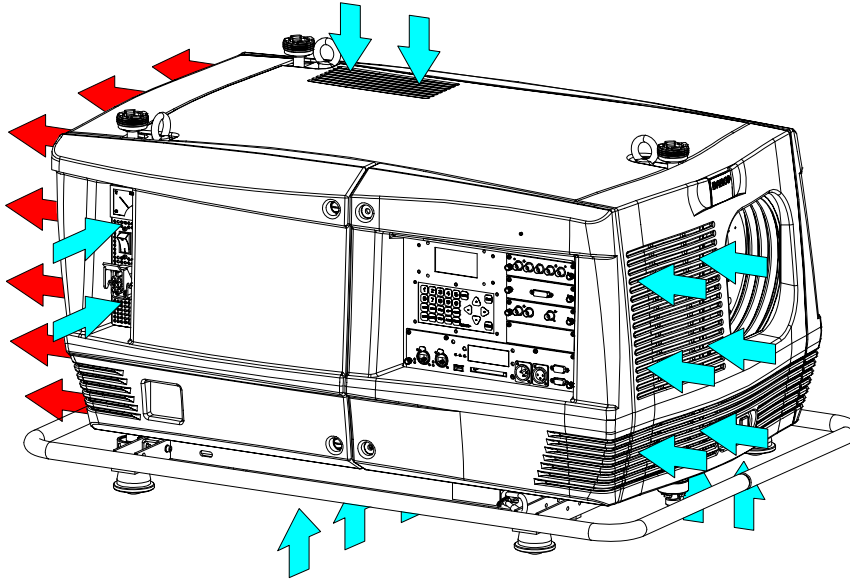

Image 2-11

The FLM HD20 has 5 air inlet channels and one air outlet. The air outlet is located at the rear of the projector. The air inlets are located at the front, bottom, top and right side of the projector.

## 2.7 Free download of Projector Toolset

### About Projector Toolset

Projector Toolset is a software tool to set up, configure, manage and control Barco projectors.

The concept of this Projector Toolset software is modular. The basic package can be extended with several optional device plug-in modules, now and in the future available.

The Projector Toolset software works with configurations that can be loaded. Within a configuration, different snapshots can be taken. A snapshot represents a current state of a configuration and can be reloaded to return to this typical state. These terms will be used through the complete software.

Projector Toolset is a stand-alone application that runs on a Java Virtual Machine and that does not require extra services to run.

Several configurations can be controlled simultaneously. Even when the configurations are connected via different ways.



**Projector Toolset is only available in a download version, no CD can be ordered.**

### Where to find the download file(s)

The program and all necessary plug-ins, as well as the Reference manual can be downloaded for free from Barco's Partnerzone, URL <https://my.barco.com>. Registration is necessary.

If you are not yet registered, click on Partnerzone registration and follow the instructions. With the created login and password, it is possible to enter the partnerzone where you can download the Projector Toolset software and the device plug-in updates as well as the corresponding reference manual.

When downloading the complete Projector Toolset, this software contains already the latest device plug-ins. When you already have the latest core version of Projector Toolset, it is possible to download only device plug-in updates from the same web site location.

As Projector Toolset is a stand alone application, it is not necessary to install any other software. A Java virtual machine is included with this download.

### Installation

Download first the reference manual (Part number: R59770052) and follow the installation instructions as written in this manual.

## 3. PHYSICAL INSTALLATION

### About this chapter

This chapter explains how to install and set up your FLM projector. If you are familiar with the projector and want to quickly set it up for temporary use, follow the "Quick setup" instructions below. For a more complete setup, follow the instructions and guides covered in the remaining subsections.

### Quick setup

The following steps describe briefly how to setup your FLM projector in a table mount front projection. Note that each step refers to a corresponding procedure, which is more detailed and illustrated.

1. Install the batteries of the remote control, see "RCU battery installation", page 20.
2. Place the projector on a solid table in front of the screen at the expected throw distance. Ensure that the projector is installed at right angles (horizontally and vertically) with the screen.
3. Select and install an appropriate lens, which covers the throw ratio (= screen size / projector screen distance). For more details see "Lens selection", page 23, and "Lens installation", page 24.
4. Connect the projector with the local power net, see "Power connection", page 35.
5. Connect your source to the appropriate input module, see "Input source connections", page 37.
6. Switch ON the projector, see procedure "Switching on", page 45.
7. Select the input slot at which your source is connected with. Do this by pressing the numeric key "1", "2", "3" or "4" on the remote control unit or on the local keypad, see chapter "Source selection", page 53.
8. Zoom and shift the lens until the image is properly projected on the screen, Do this by using the "ZOOM" and "FOCUS" key on the remote control unit or on the local keypad, see "Quick Lens Adjustment via LENS key", page 49 or "Direct Lens Adjustment (RCU)", page 50. If necessary, level the projector from side to side by turning the adjustable feet in or out, see "Alignment of a table mount FLM projector", page 27.

### 3.1 Remote control unit (RCU)

#### Introduction

The remote control unit (A) of the FLM projector is equipped with a rugged case (B) and an XLR adaptor (C). The remote control unit can be used wired via mini-jack or via rugged XLR. Note that the backlight, of the remote control unit, illuminate continuously when wire connected.

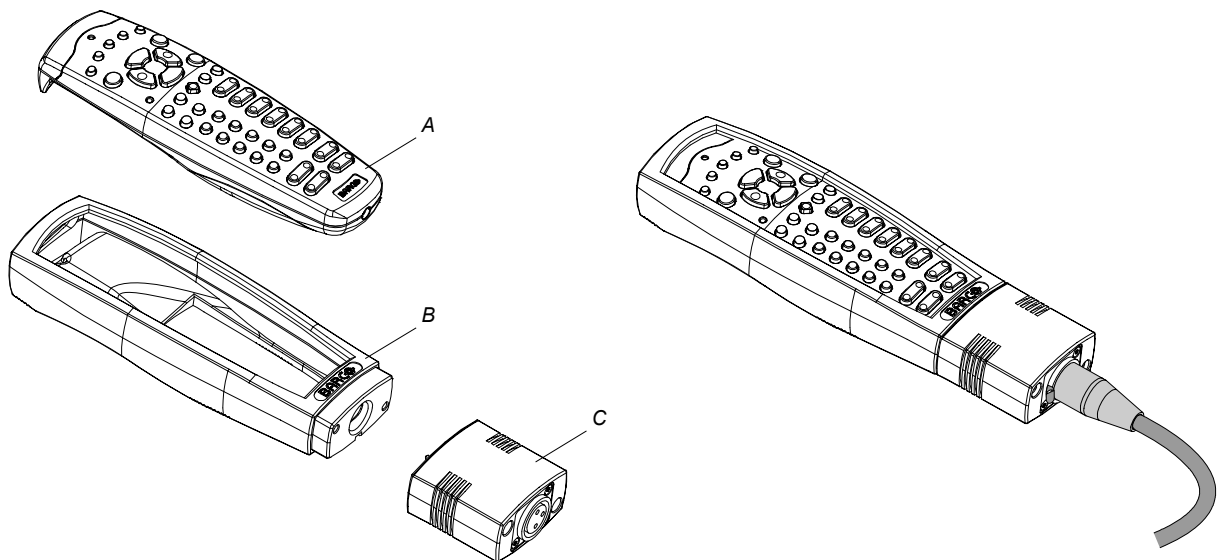

Image 3-1

- A Remote control unit (RCU).
- B Rugged case.
- C XLR adaptor.

#### Overview

- RCU battery installation
- RCU rugged case installation
- RCU XLR adaptor installation
- Using the XLR adaptor of the RCU
- RCU usage possibilities

#### 3.1.1 RCU battery installation

##### Where to find the batteries for the remote control ?

The batteries are not placed in the remote control unit to avoid control operation in its package, resulting in a shorter battery life time. At delivery the batteries can be found in a separated bag attached to the remote control unit. Before using your remote control, install the batteries first.

##### How to install the batteries in the remote control ?

1. Push the battery cover tab with the fingernail a little backwards (1) and pull, at the same time, the cover upwards (2).

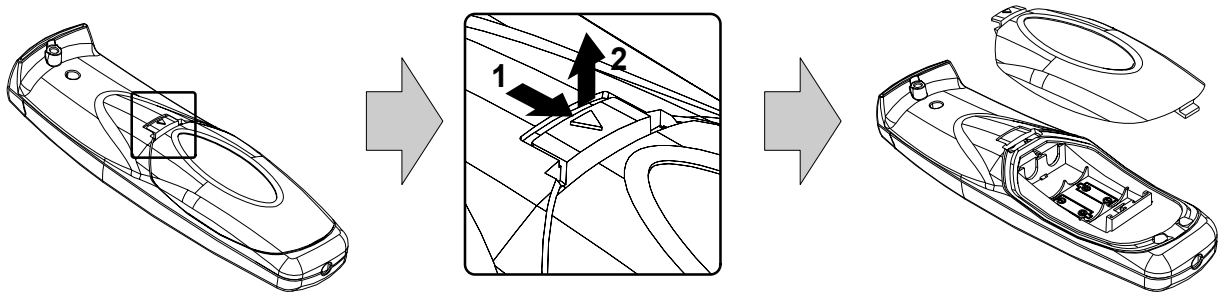

Image 3-2

2. Insert the two AA size batteries, making sure the polarities match the + and - marks inside the battery compartment.

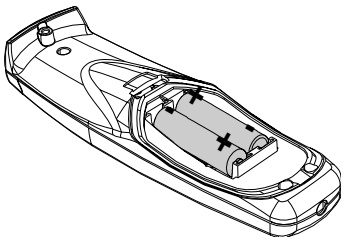

Image 3-3

3. Insert (1) the lower tab of the battery cover in the gap at the bottom of the remote control, and press (2) the cover until it clicks in place.

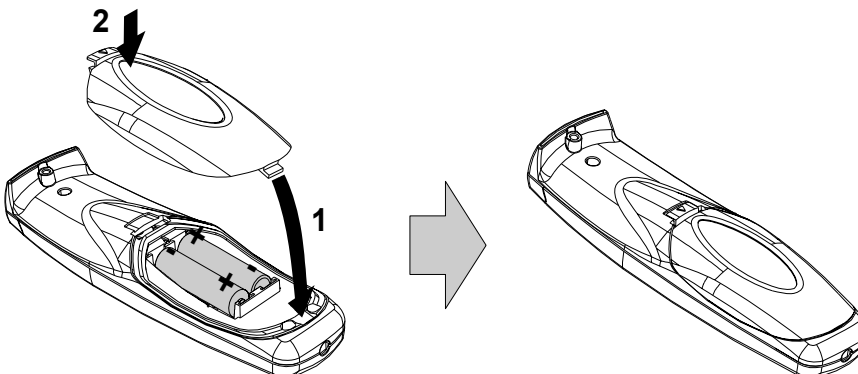

Image 3-4

##### To prevent battery explosion

- Danger of explosion if battery is incorrectly installed.
- Replace only with the same or equivalent type recommended by the manufacturer.
- Disposal of used batteries must be done according to the manufacturer's instruction.

### 3.1.2 RCU rugged case installation

#### How to install the rugged case of the remote control ?

1. Slide the bottom of the RCU into the rugged case and then pull the top of the rugged case over the top of the RCU as illustrated.

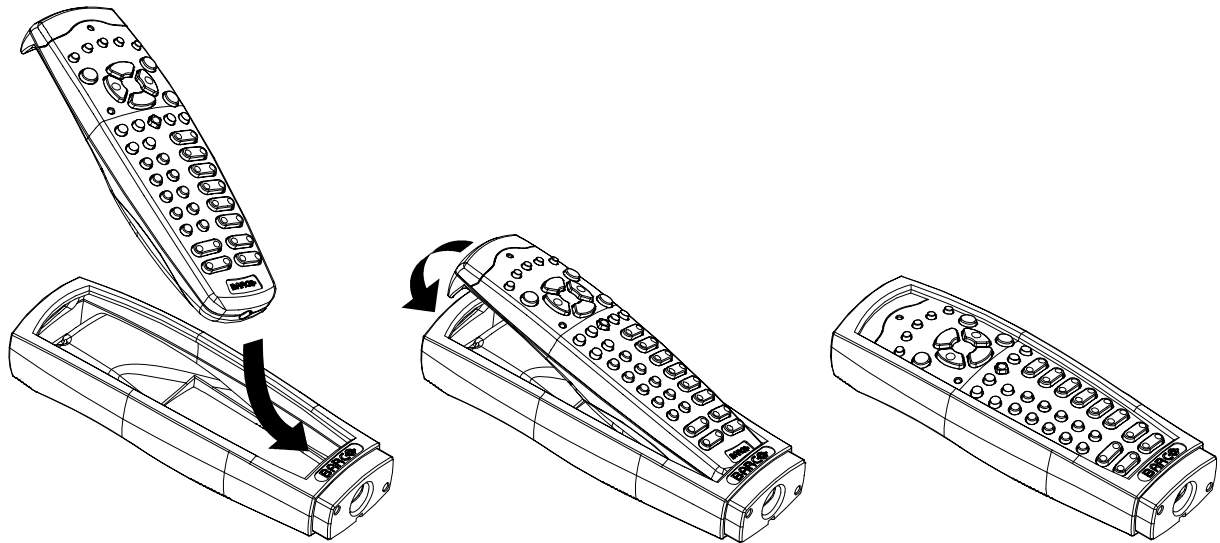

Image 3-5

### 3.1.3 RCU XLR adaptor installation



Install the rugged case before installing the XLR adaptor. Vice-versa, remove the XLR adaptor before removing the rugged case from the RCU.

#### Necessary tools

5 mm flat screw driver.

#### How to install the XLR adaptor of the remote control unit ?

1. Push the XLR adaptor (C) upon the rugged case of the remote control unit as illustrated.

**Note:** Ensure that the text of the XLR adaptor is on top.

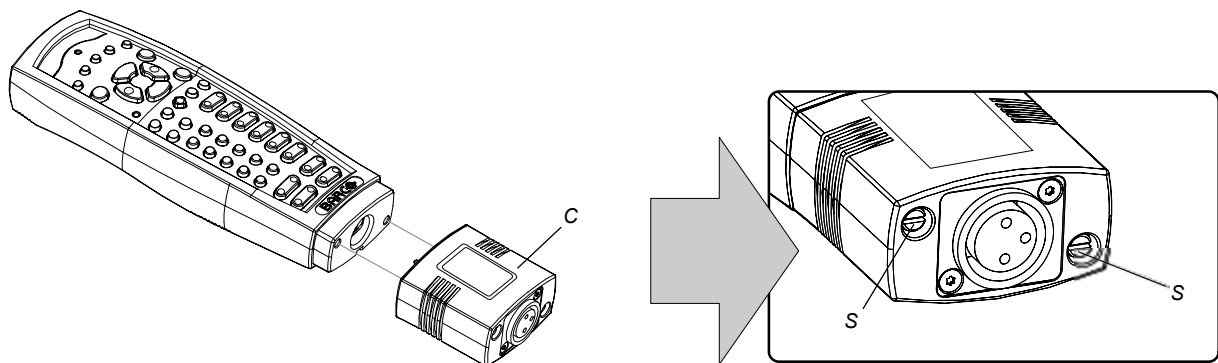

Image 3-6

2. Fasten the two screws (S) of the XLR adaptor. Turn each screw repeatedly one or two turns until both screws are tight.

### 3.1.4 Using the XLR adaptor of the RCU

#### How to use the XLR adaptor of the remote control unit ?

1. Connect a cable with XLR plug into the XLR adaptor.
2. Connect the other end of the cable with your FLM HD20.
3. Push the XLR adaptor completely against the rugged case of the remote control unit, as illustrated in the left image below, for wired communication. Pull out the XLR adaptor (about 8 mm) to switch over to wireless communication.

### 3. Physical installation

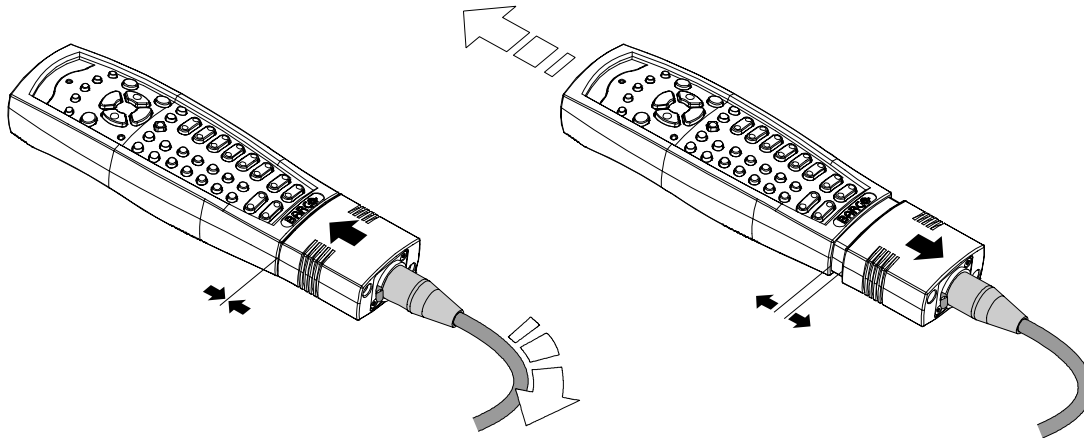

Image 3-7

#### 3.1.5 RCU usage possibilities

##### Summarized possibilities

| Ref. | Possibility description  | Comment  |
|------|--|--|
| a.   | RCU not wired  |  |
| b.   | RCU wired (mini-jack)  | Backlight illuminates continuously when wire is connected. Infra red disabled.   |
| c.   | RCU with rugged case not wired   |  |
| d.   | RCU with rugged case wired (mini-jack)                                 | Backlight illuminates continuously when wire is connected. Infra red disabled.   |
| e.   | RCU with rugged case and XLR adaptor pulled out "REMOTE" and not wired | The XLR adaptor must be in the pulled out position "REMOTE", otherwise the RCU will not function.  |
| f.   | RCU with rugged case and XLR adaptor pulled out "REMOTE" and wired     | The RCU will send the commands via infra red to the projector.   |
| g.   | RCU with rugged case and XLR adaptor pushed in "WIRED" and wired       | The RCU will send the commands via the cable connected with the XLR adaptor to the projector. Backlight illuminates continuously when wire is connected. Infra red disabled. |

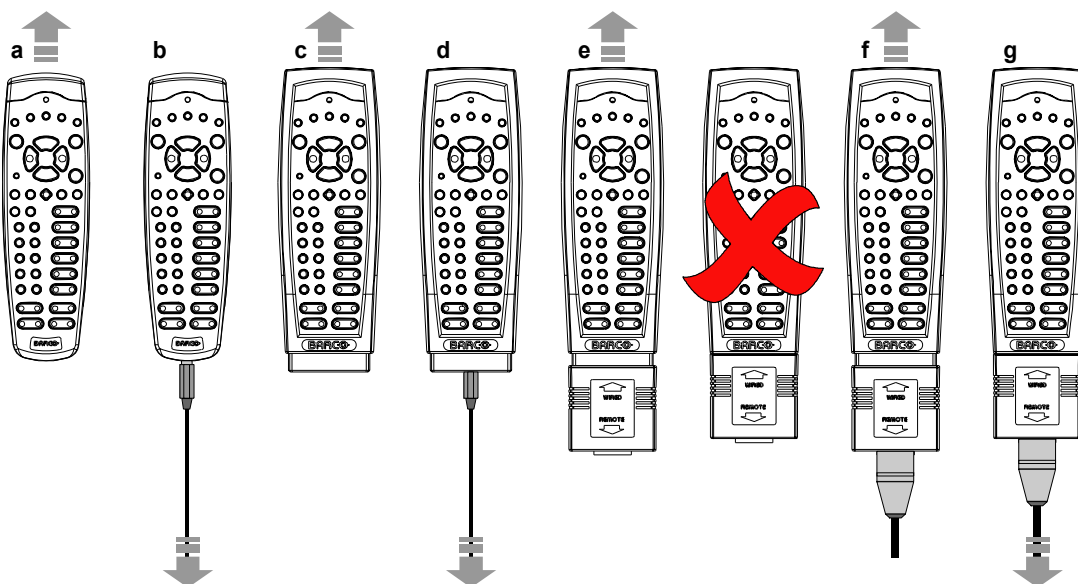

Image 3-8

## 3.2 Lenses

### 3.2.1 Available lenses

#### Available lenses for the FLM HD20 projector

The TLD HB (High Brightness) lens series can be used on the FLM HD20 projector.



Image 3-9  
R9842040: TLD HB fixed lens (0.8 : 1)



Image 3-10  
R9840770: TLD fixed lens (1.2 : 1)



Image 3-11  
R9840775: TLD+ (1.2 : 1) fixed lens



Image 3-12  
R9842060: TLD HB zoom lens (1.6 - 2.0 : 1)



Image 3-13  
R9842080: TLD HB zoom lens (2.0 - 2.8 : 1)



Image 3-14  
R9842100: TLD HB zoom lens (2.8 - 5.0 : 1)



Image 3-15  
R9842120: TLD HB zoom lens (5.0 - 8.0 : 1)

### 3.2.2 Lens selection

#### How to select the right lens for your application ?

1. Determine the required screen width (SW).
2. Determine the position of the projector in the projection room with regard to the screen and measure the projector-screen distance (PD).

### 3. Physical installation

- Use the lens formulas to find the best corresponding PD with regard to the measured projector-screen distance for the required screen width SW.

**Tip:** Divide PD by SW to determine the approximate throw ratio. Choose a Lens, which captures the calculated throw ratio. Use the lens formula of the chosen Lens to recalculate exactly.

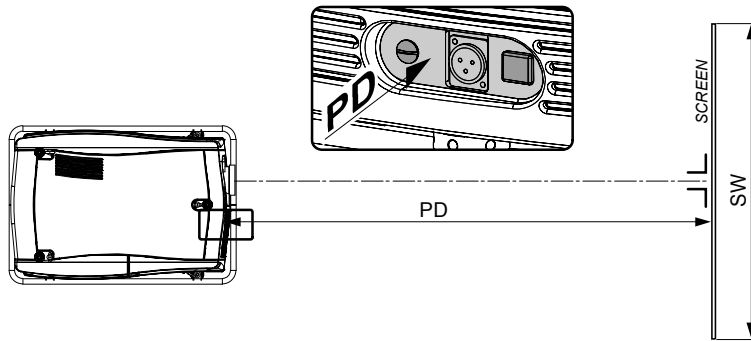

Image 3-16

#### 3.2.3 Lens formulas

##### Formulas

| Lens                   | Throw ratio for FLM HD | Metric formulas (meter)  | Inch formulas (inch)   |
|------------------------|------------------------|--|--|
| TLD HB (0.8 : 1)       | 0.7                    | $PD = (0.71 \times SW) + 0.05$   | $PD = (0.71 \times SW) + 1.97$   |
| TLD (1.2 : 1)          | 1.1                    | $PD = (1.03 \times SW) - 0.01$   | $PD = (1.03 \times SW) - 0.39$   |
| TLD+(1.2:1)            | 1.2                    | $PD = (1.14 \times SW) + 0.11$   | $PD = (1.14 \times SW) + 4.33$   |
| TLD HB (1.6 – 2.0 : 1) | 1.35 – 1.70            | $PD_{min} = (1.36 \times SW) - 0.09$<br>$PD_{max} = (1.71 \times SW) - 0.13$ | $PD_{min} = (1.36 \times SW) - 3.54$<br>$PD_{max} = (1.71 \times SW) - 5.12$   |
| TLD HB (2.0 – 2.8 : 1) | 1.70 – 2.42            | $PD_{min} = (1.71 \times SW) - 0.17$<br>$PD_{max} = (2.42 \times SW) - 0.24$ | $PD_{min} = (1.71 \times SW) - 6.69$<br>$PD_{max} = (2.42 \times SW) - 9.45$   |
| TLD HB (2.8 – 5.0 : 1) | 2.42 – 4.35            | $PD_{min} = (2.38 \times SW) - 0.16$<br>$PD_{max} = (4.35 \times SW) - 0.38$ | $PD_{min} = (2.38 \times SW) - 6.30$<br>$PD_{max} = (4.35 \times SW) - 14.96$  |
| TLD HB (5.0 – 8.0 : 1) | 4.35 – 6.95            | $PD_{min} = (4.17 \times SW) - 0.01$<br>$PD_{max} = (6.95 \times SW) - 0.29$ | $PD_{min} = (4.17 \times SW) - 0.39$<br>$PD_{max} = (6.95 \times SW) - 11.42$  |
| TLD+(7.5 – 11.2 : 1)   | 6.93 - 10.34           | $PD_{min} = (6.93 \times SW) - 0.2$<br>$PD_{max} = (10.34 \times SW) - 0.32$ | $PD_{min} = (6.93 \times SW) - 7.88$<br>$PD_{max} = (10.34 \times SW) - 12.60$ |

#### 3.2.4 Lens installation

##### How to install a lens into the projector lens holder ?

- Remove the foam rubber in the opening of the lens holder if not removed yet.
- Take the lens assembly out of its packing material and remove the lens caps on both sides.
- Place the lens holder in the “unlocked” position by moving the lens lock handle (A) towards the lens power supply socket (B) as illustrated.



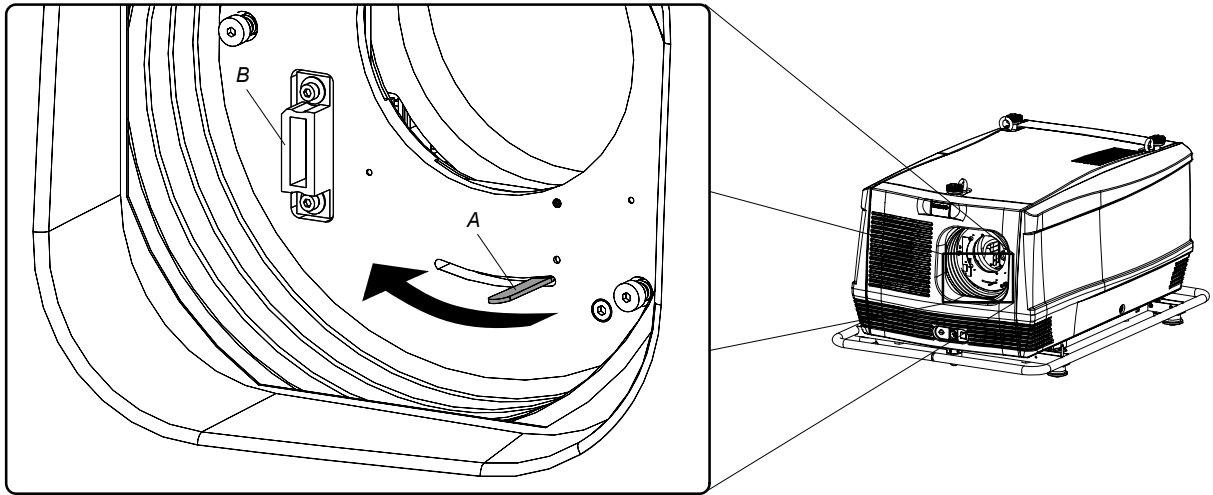

Image 3-17

4. Ensure that the lens holder stands in the On-Axis position (horizontal and vertical mid position).  
**Note:** *The lens holder is placed default in the On-Axis position at factory.*
5. Gently insert the lens in such a way that the lens connector matches the socket (B).

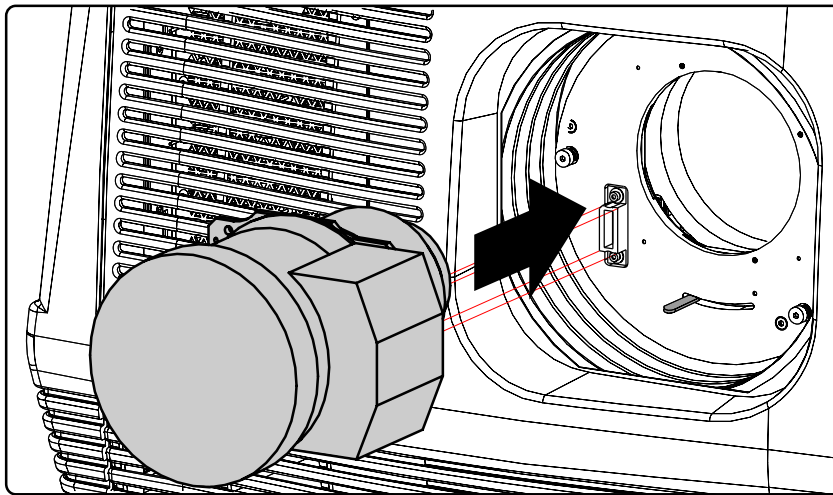

Image 3-18

6. Insert the lens until the connector seats into the socket.  
**Warning:** *Do not release the Lens yet, as the Lens may fall out of the Lens Holder.*
7. Secure the lens in the lens holder by sliding the lens lock handle into the "locked" position, which is away from the lens power supply socket. Ensure the lens touches the front plate of the lens holder.

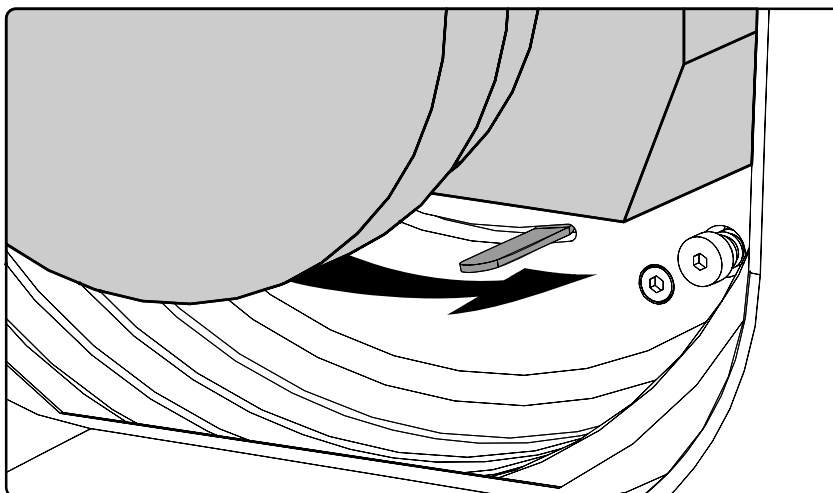

Image 3-19

8. Check if the lens is really secured by trying to pull the lens out of the lens holder.



**CAUTION:** Never transport the projector with a Lens mounted in the Lens Holder. Always remove the Lens before transporting the projector. Neglecting this can damage the Lens Holder and Prism.

---

### 3.2.5 Lens removal

#### How to remove a lens from the projector lens holder ?

1. Support the lens with one hand while you unlock the lens holder by sliding the lock handle towards the “unlocked” position as illustrated.

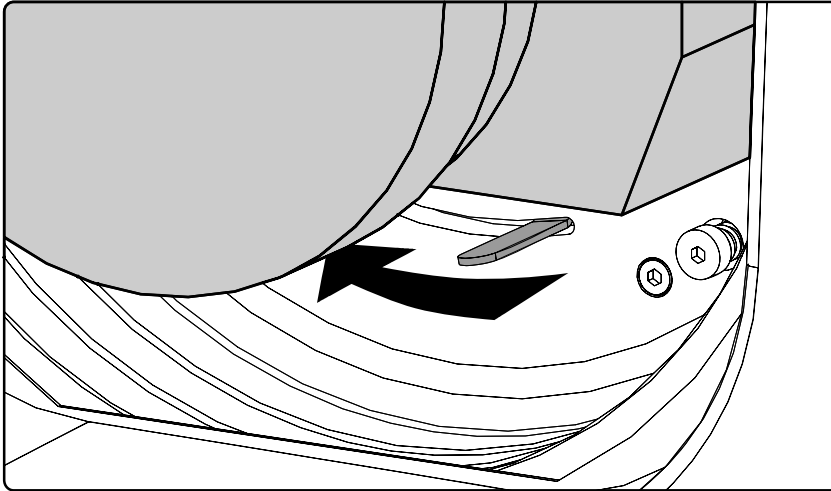

Image 3-20

2. Gently pull the lens out of the lens holder.

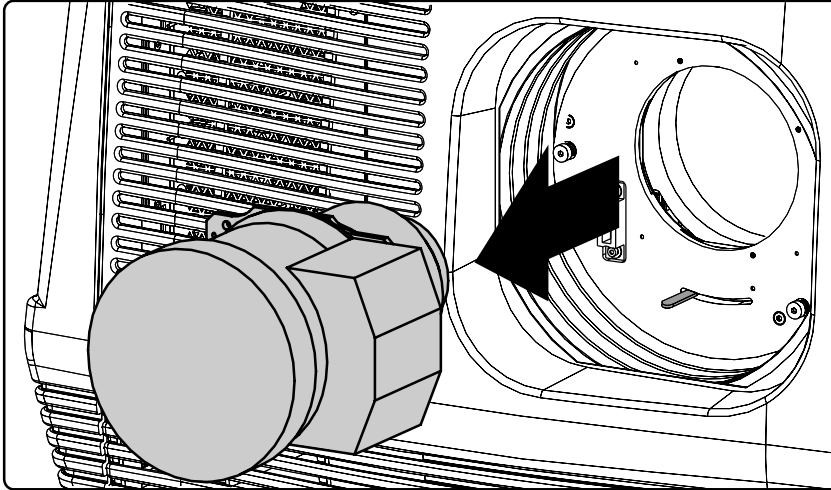

Image 3-21



It's recommended to place the Lens caps of the original Lens packaging, back on both sides of the removed Lens to protect the optics of the Lens.

---



It's recommended to place the foam rubber of the original projector packaging, back in the Lens opening to prevent intrusion of dust. Note that this foam rubber is packed in a plastic bag to prevent the dust, emitted by the foam, from entering the projector.

---

### 3.3 Alignment of a table mount FLM projector

#### How to align a table mount FLM projector ?

1. Place the projector in the desired location. Take into account the zoom range of the used lens and the size of the screen.
2. Project one of the internal hatch patterns on the screen.
3. Turn the adjustable feet in or out until the projected hatch pattern is perfectly rectangle shaped and leveled.

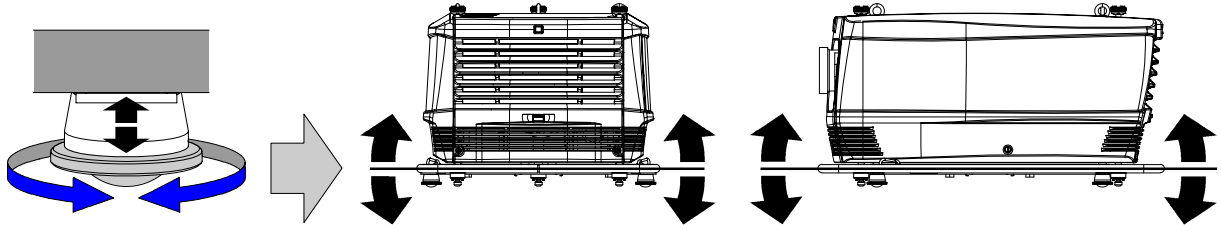

Image 3-22

When this is achieved, the projector is set horizontal and vertical at right angles to the screen.

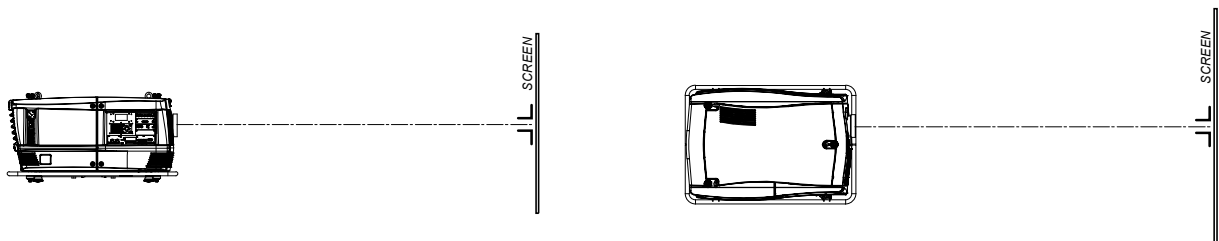

Image 3-23

### 3.4 Alignment of a ceiling mount FLM projector

#### Necessary tools

17 mm open ended spanner.

#### How to align a ceiling mount FLM projector ?

1. Install the projector in the desired location. See installation procedure "Suspension of the FLM projector with rigging clamps", page 28. Take into account the zoom range of the used lens and the size of the screen.
2. Project one of the internal hatch patterns on the screen.
3. Release the lock nut (ref B image 3-24) of the rigging clamps.
4. Adjust the height of the rigging clamps with respect to the projector, until the projected hatch pattern is perfectly rectangle shaped and leveled.

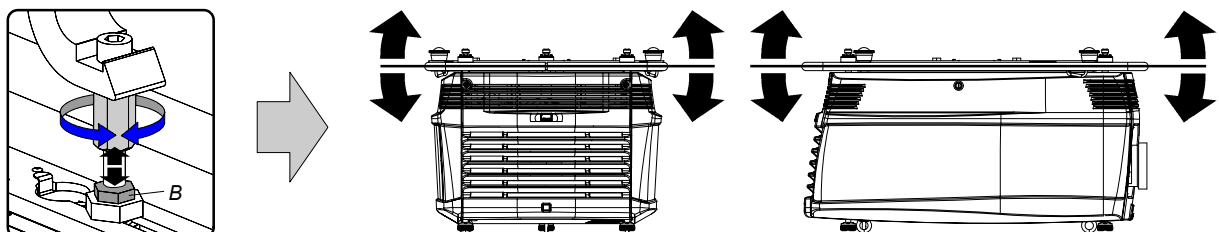

Image 3-24

### 3. Physical installation

When this is achieved, the projector is set horizontal and vertical at right angles to the screen.

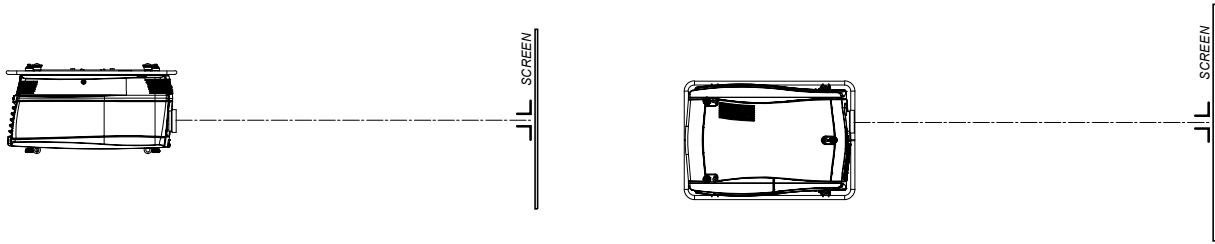

Image 3-25

5. Fasten the lock nut (B) of the rigging clamps.

## 3.5 Suspension of the FLM projector with rigging clamps

### Rigging points and rigging clamps

The carrying handle, at the bottom side of the projector, is provided with eight slots. Four slots are longitudinally (A) oriented and four slots are transversely (B) oriented. Each slot contains a rigging point of which the position in the slot can be adjusted depending on the size of the truss installation. The rigging clamps (C) can be attached to those rigging points, which allows an easy and fast physical setup of the projector in a hanging configuration.

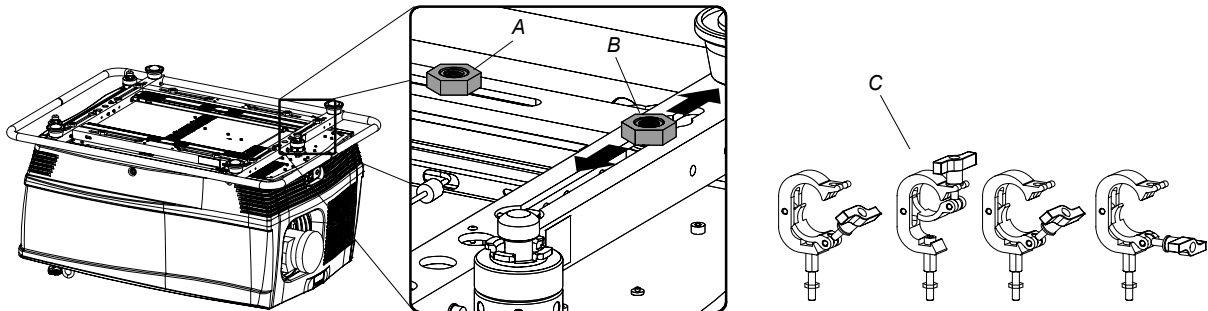

Image 3-26

### Necessary tools

- 24 mm open ended spanner.
- 17 mm open ended spanner.

### Necessary parts

- Four rigging clamps (R820411).
- Safety chains.

### How to install and to use the rigging clamps ?

1. Measure the distance, center tube as reference, between the two used support bars of the truss.

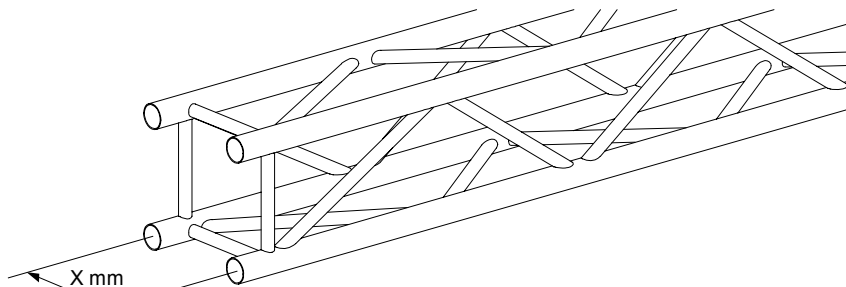

Image 3-27

2. Turn the projector upside down and slide the rigging points on there place in the slots, according the measured distance and secure this position. To release the nuts of the rigging points use a 24 mm open ended spanner. Ensure that the rigging points are symmetrically lined up, so that the projector will hang in balance.

**Warning:** Be careful while working with heavy loads.

**Warning:** Always secure the rigging points after adjustment.

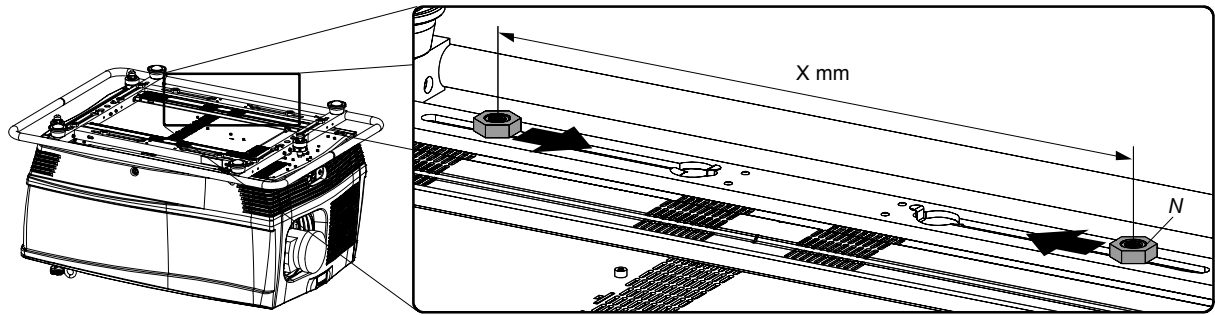

Image 3-28

- Turn in the rigging clamps (A) into the rigging points using a 17 mm open ended spanner and secure the rigging clamps by turning the safety nut (B) on the rigging clamp against the rigging point using a 17 mm open ended spanner.  
**Warning:** Always use four (4) rigging points, equally spread, to suspend the projector.

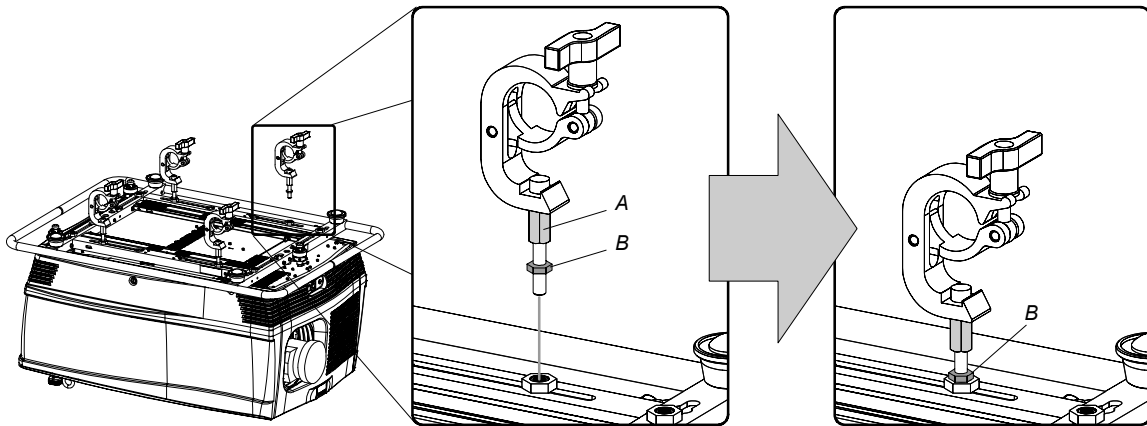

Image 3-29

- Place all four rigging clamps in open position as illustrated.

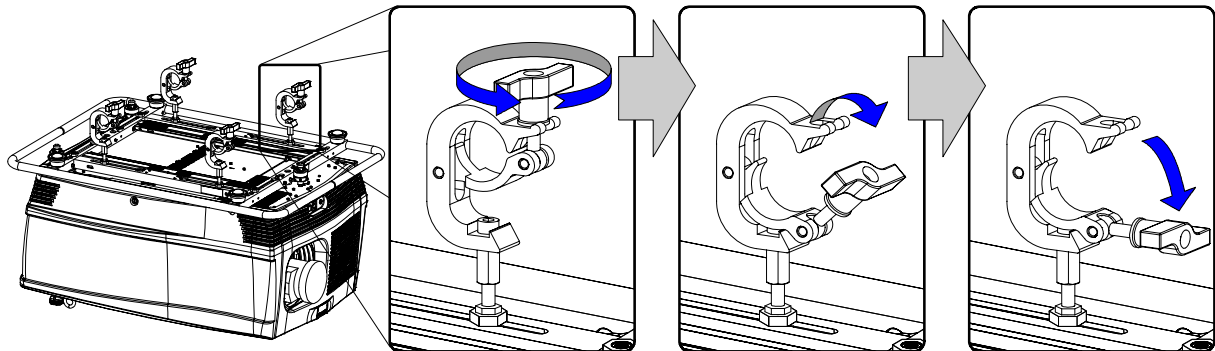

Image 3-30

- Place the projector (upside down) under the truss installation and lower the truss until the support bars of the truss are nearby the rigging clamps mounted on the projector.

### 3. Physical installation

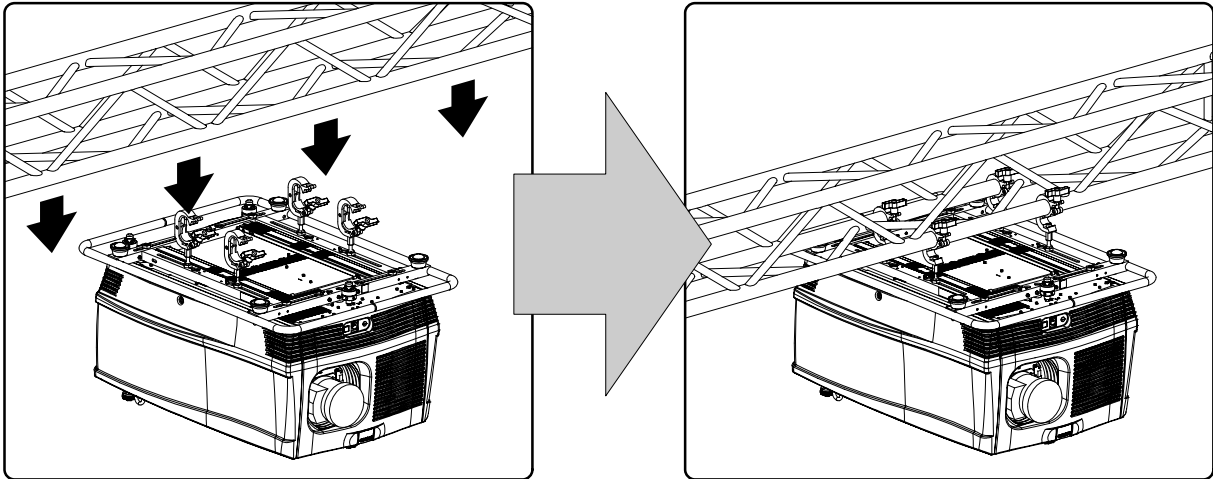

Image 3-31

6. Lift up the projector and hook the four rigging clamps over the support bars of the truss.
7. Lock all four rigging clamps.
8. Install a safety chain (S) around both sides of the carrying handle and around the truss.

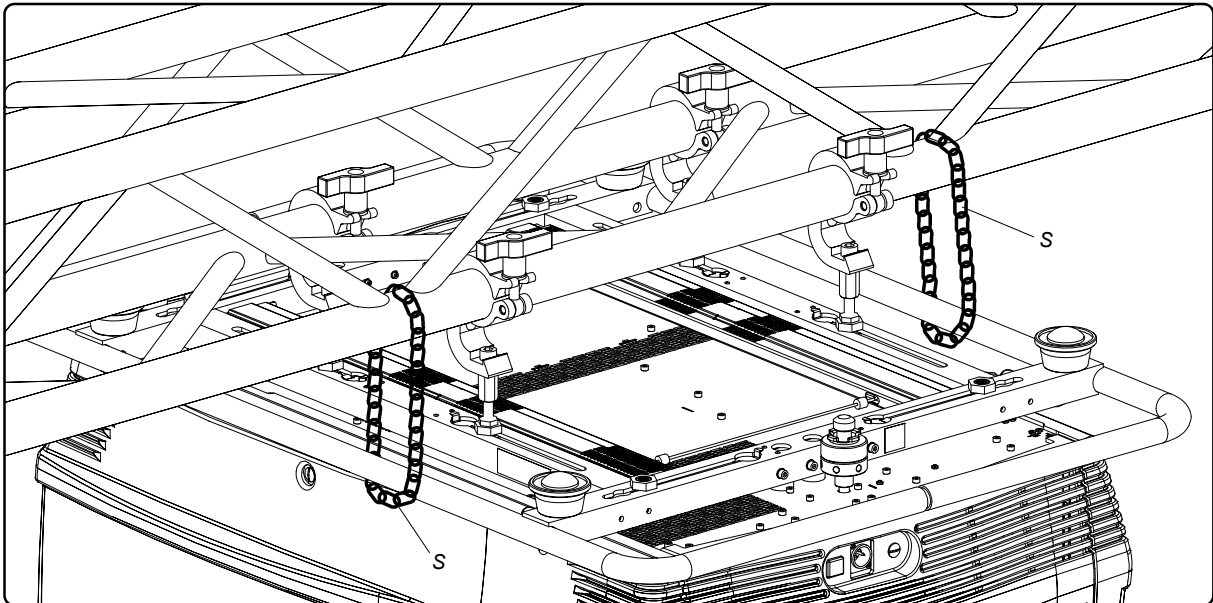

Image 3-32

9. Lift up the truss with attached projector to the desired height.



Proceed with the alignment procedure, see "Alignment of a ceiling mount FLM projector", page 27.

## 4. STACKING FLM PROJECTORS

### General

Three interlocking adapters at the top and at the bottom of the FLM projector allows an easy and fast stacking without using extra tools or accessories.



**WARNING:** Maximum stack three (3) FLM projectors in a table mount configuration.

Maximum stack two (2) FLM projectors in a ceiling mount configuration.

### Overview

- Stacking FLM projectors
- Aligning stacked FLM projectors

### 4.1 Stacking FLM projectors

#### How to stack FLM projectors ?

1. Turn in the four feet of the projector you want to stack.
2. Place the projectors on top of each other. Ensure that all three interlocking pins (A) match with their corresponding interlocking sockets (B).

**Tip:** In case of stacking projectors for a ceiling mount configuration, first turn the projectors upside down before placing the projectors on top of each other.

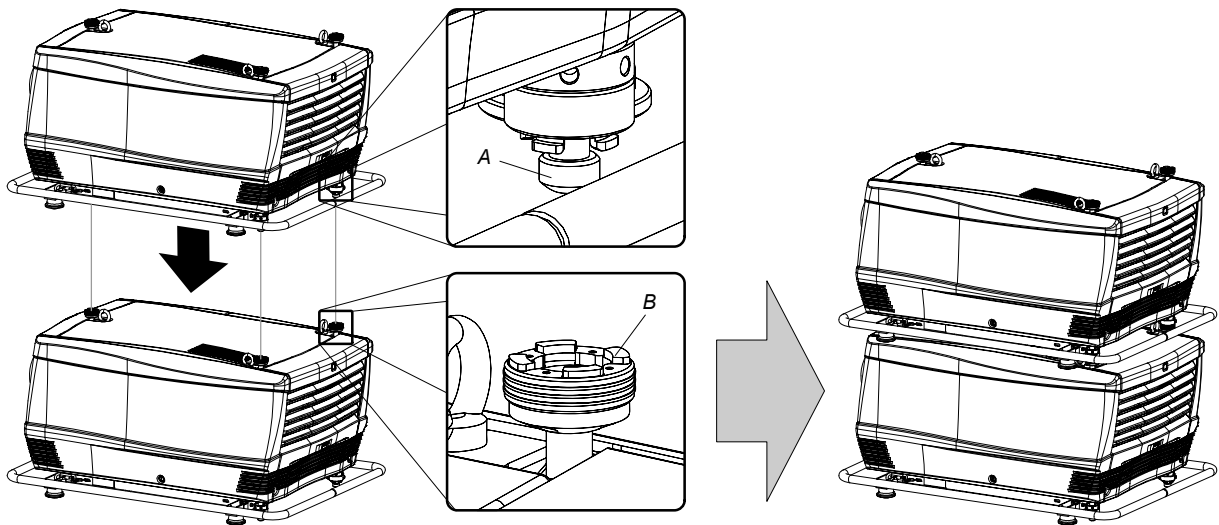

Image 4-1

3. Attach the two projectors together by closing all three interlocking adapters as illustrated.

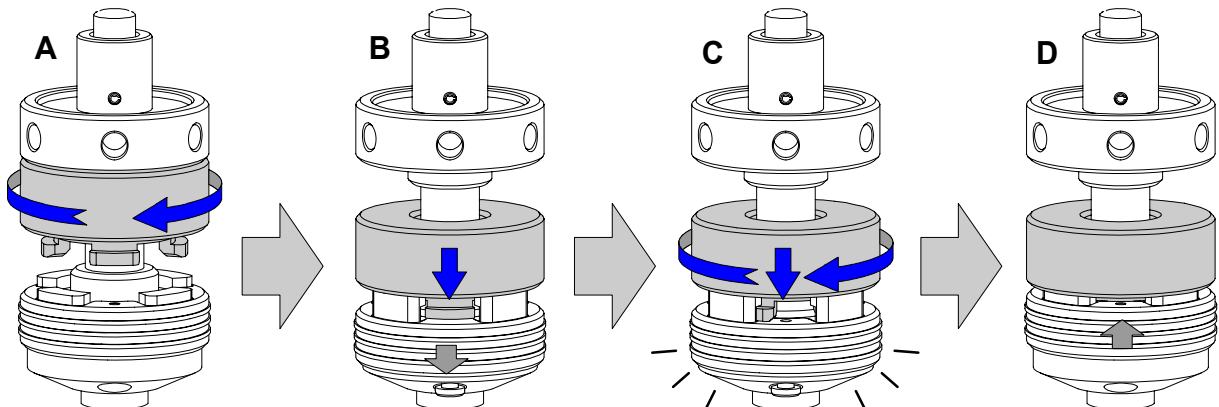

Image 4-2



#### 4. Stacking FLM projectors

4. Are these projectors stacked for a ceiling mount configuration?

If yes, secure the projectors with safety chains as follows:

a) Release the safety hook (H) at both sides of the lowest projector and guide the safety cable around its carrying handle (C) as illustrated.

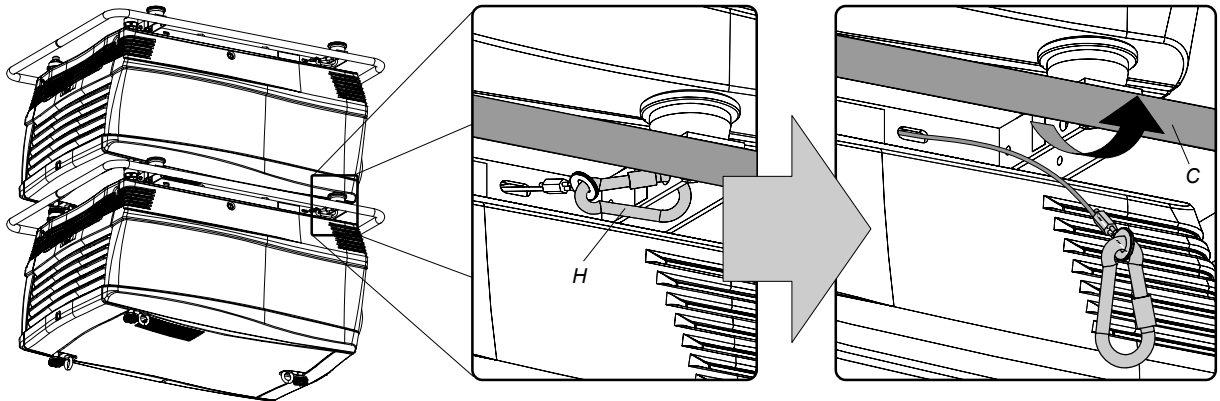

Image 4-3

b) Guide the safety cable around the carrying handle of the projector above and clasp the safety hook around the safety cable as illustrated.

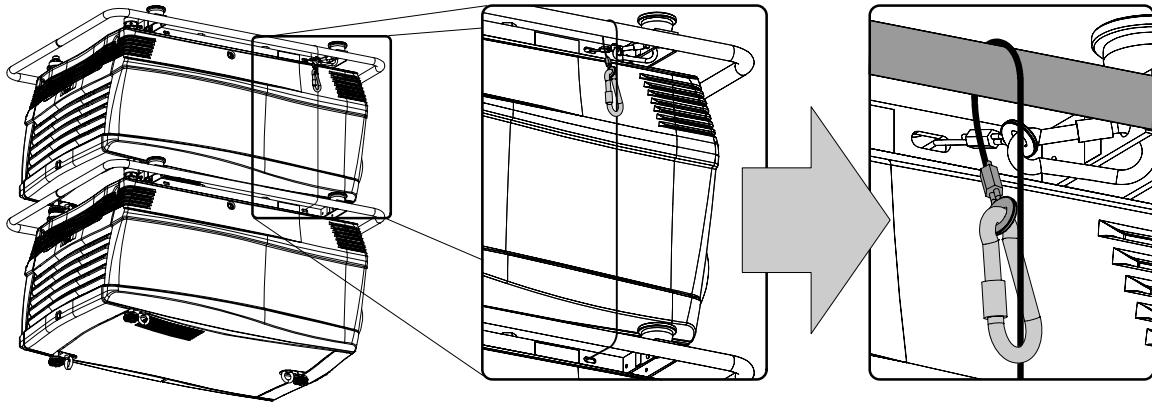

Image 4-4



**WARNING:** Always use both safety cables of the lowest projector to secure a stacked projector in a ceiling mount configuration.

#### How to open an interlocking adapter ?

1. Open an interlocking adaptor as illustrated.

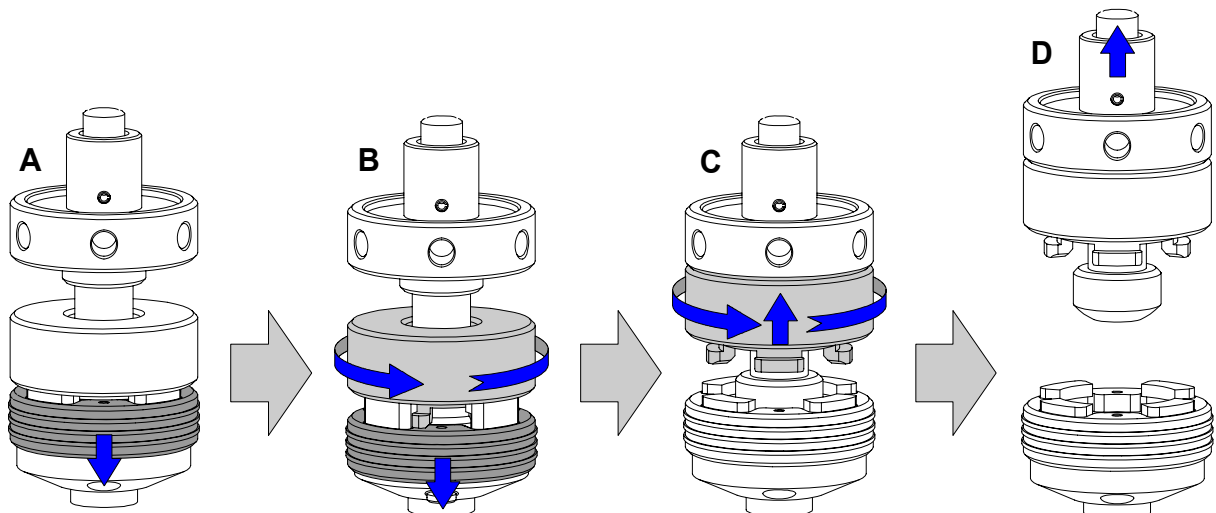

Image 4-5





**WARNING:** Never open an interlocking adapter of a stacked projector which is still suspended. First place the stacked projectors on the floor.

## 4.2 Aligning stacked FLM projectors

### Necessary tools

8 mm Allen key.

### How to align two stacked FLM projectors ?

1. Make sure that the internal hatch pattern projected by the reference projector is sharp and has a perfect rectangle outline. If this is not the case, readjust the reference projector before aligning the other stacked projector(s) with the reference hatch pattern.  
**Note:** The reference projector in a stacked configuration is the lowest projector in case of table mount and the uppermost projector in case of ceiling mount.
2. Project with the stacked projector the same internal hatch pattern as the reference projector.  
**Tip:** Use a white colored hatch pattern for the reference projector and e.g. green colored for the stacked projector. This makes it easier to see the difference between both hatch patterns projected.
3. If necessary, adjust the rotation of the stacked projector with respect to the reference projector by turning in or out the height adjustment ring of the interlocking adapters at the rear of the stacked projector. Adjust until the outline of the hatch pattern is most symmetric with the reference hatch pattern.  
**Tip:** You can increase leverage by using a screw driver in the holes of the adjustment ring

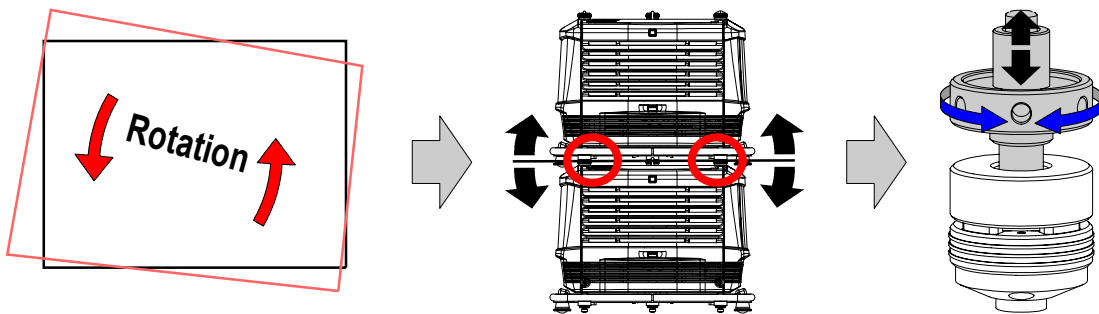

Image 4-6

4. If necessary, adjust the inclination of the stacked projector with respect to the reference projector by turning the height adjustment ring of the interlocking adapter at the front of the stacked projector in or out. Adjust until the outline of the hatch pattern is most symmetric with the reference hatch pattern.

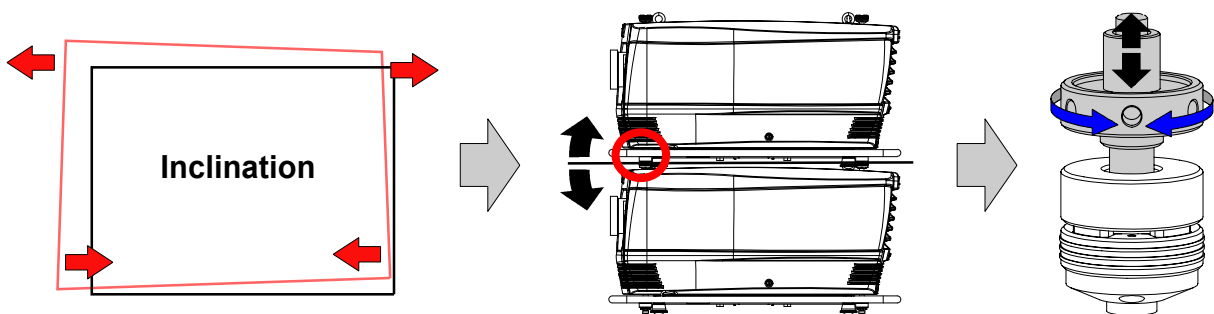

Image 4-7

5. If necessary, adjust the skew of the stacked projector with respect to the reference projector by turning the screw Q in or out using a 8 mm Allen key. The screw Q is located behind the cover of the lamp, just above the volt meter. Adjust until the outline of the hatch pattern is most symmetric with the reference hatch pattern.  
**Note:** See procedure "Removal of the lamp cover", page 193, to access the skew adjustment screw Q.

#### 4. Stacking FLM projectors

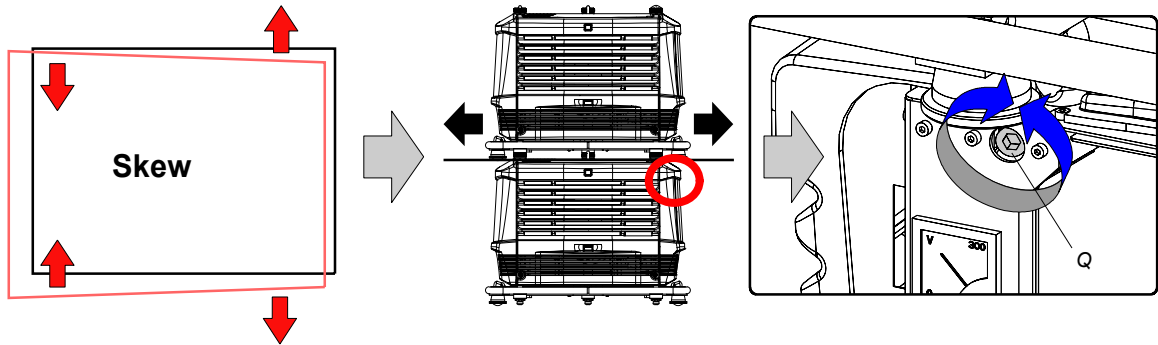

Image 4-8

6. Shift the hatch pattern horizontally and vertically until the outline of the hatch pattern is most symmetrically placed with respect to the reference hatch pattern.

**Note:** Note that the "Shift" function is motorized, which means that you have to access the projector software, via the local keypad or remote control unit, to operate the "Shift" function.

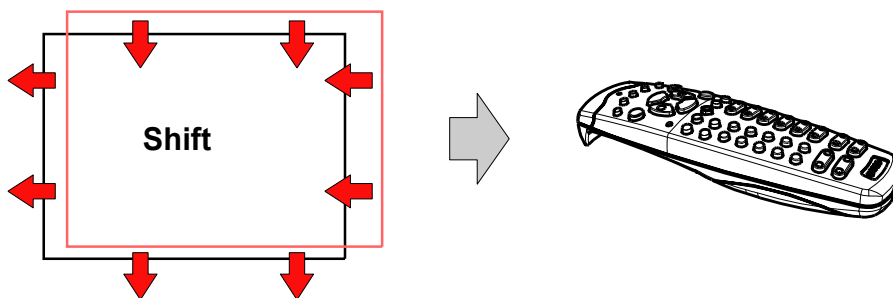

Image 4-9

7. Zoom the hatch pattern in or out until the outline of the hatch pattern matches exactly the outline of the reference hatch pattern.

**Note:** Note that the "Zoom" function is motorized, which means that you have to access the projector software, via the local keypad or remote control unit, to operate the "Zoom" function.

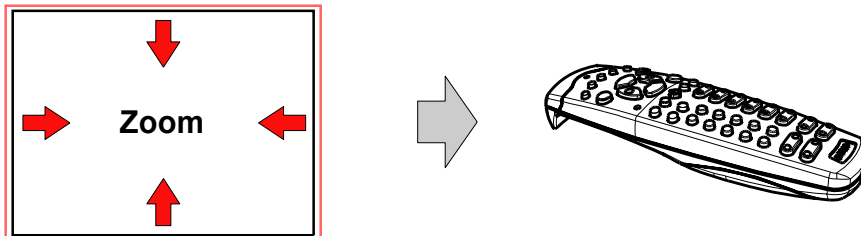

Image 4-10

8. If necessary, repeat from step 2 until the hatch pattern of the stacked projector is perfectly aligned with the hatch pattern of the reference projector.



**In case of a triple stacked table mount projector configuration adjust and align first the bottommost projector (reference), then the projector in the middle and finally the uppermost projector.**

## 5. CONNECTIONS

### About this chapter

This chapter describes more in detail the power (P), the input source (S) and the communication (C) connections of the FLM HD20.

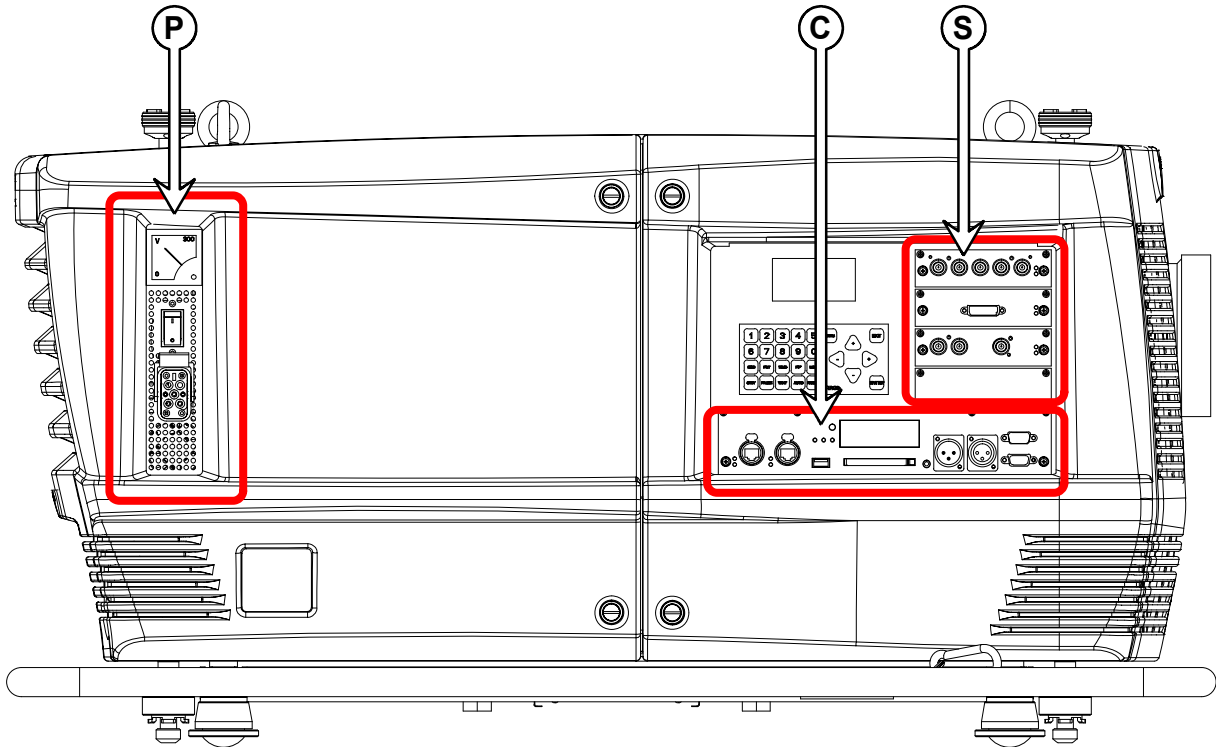

Image 5-1

### Overview

- Power connection
- Input source connections
- Communication connections

## 5.1 Power connection



**CAUTION:** Use only the power cord provided with the projector.

### How to connect your projector with the local power net ?

1. Ensure that the power switch (S) stands in the "0" (OFF) position.
2. Connect the power cord (P) with the power input socket of the projector as illustrated below.
3. Secure the power plug by locking the plug holder clamp (H).
4. Connect the other end of the power cord with the local power net.  
**Caution:** Ensure that the power net meets the power requirements of the projector, which are: 200-240 VAC, 50/60Hz, 20 amps at 230 VAC.

## 5. Connections

The voltmeter (M) will immediately indicate the value of the mains voltage as soon as the projector is connected with the power net.

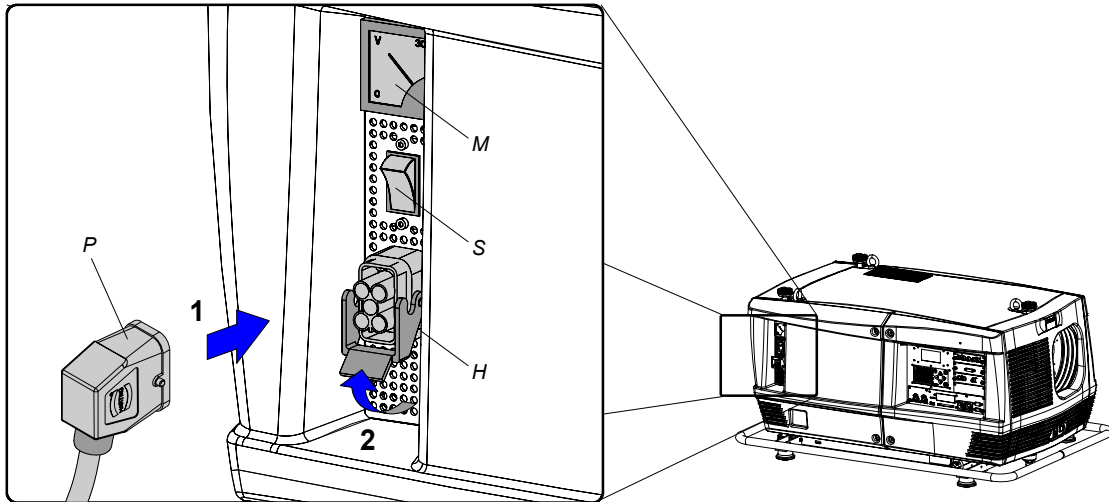

Image 5-2



**WARNING:** Do not attempt operation if the AC supply and cord are not within the specified voltage and power range.



**CAUTION:** Once the projector is switched to standby, the lamp cooling fans will continue to run for approximately five minutes to ensure that the projector and lamp have sufficiently cooled, at which point the fans will automatically decrease to standby. To avoid thermal stress that can lead to premature lamp failure, never unplug the power cord while the lamp cooling fans are running. Never unplug the power cord to power down the projector, first switch off the power switch and then unplug the power cord.

### Fuses

The projector is protected with an automatic circuit breaker of 35 A which is built in into the power switch.

### Volt meter

After starting up the projector (lamp ignition) check if the value indicated by the volt meter is still within the specified power range of the projector. Note that in case the power net drops significantly during start up, the lamp will fail the ignite. If this is the case, take the necessary measures to reinforce the power net to the projector before starting up the projector again.

### Spare power plug

The projector is delivered with a spare power plug. This spare power plug is attached behind the nameplate of the projector. Remove the cover of the lamp first to access this spare power plug, see "Removal of the lamp cover", page 193. Note that only qualified technical personnel may install a new power plug.

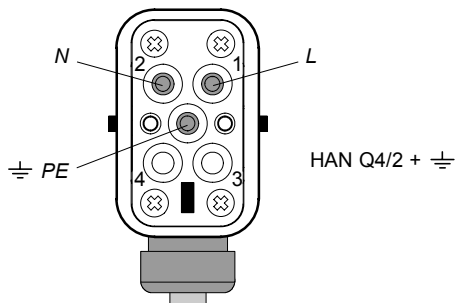

Image 5-3  
Pin configuration power plug HAN Q4/2 + PE.

## 5.2 Input source connections

### General

The input and communication unit is equipped with four input slots, which accept any type of input module designed for the FLM projector. The modularity of the input modules makes the FLM projector very flexible regarding input source connectivity. Note that the slot numbering is done from top to bottom. So, the uppermost slot is slot number "1", the second is slot number "2"... etc. All input modules have two status LED's. The green LED lights up if the input module is selected as the active input module. The yellow LED lights up if the input module has detected valid input syncs.

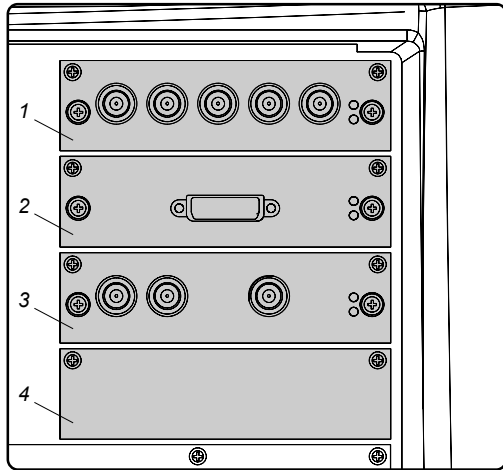
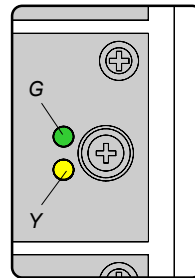

Image 5-4



**CAUTION:** Always install a cover plate on an unused input slot. This to prevent dust intrusion into the projector.

### Available input modules



Image 5-5  
5 Cable input (Multi purpose) (R9854430).



Image 5-6  
5 Cable input (Multi purpose) (R9854435).



Image 5-7  
HDSDI - SDI input (R9854450).



Image 5-8  
DVI input (R9854460).



Image 5-9  
HDCP DVI input (R9854465).



Image 5-10  
Cover plate for unused input slot (R848607).



The FLM HD20 is standard equipped with one 5 cable input module, one HDSDI - SDI input module and one DVI input module. Input slot number 4 (lowermost) is covered with a input cover plate.



For more information about the FLM input modules see chapter "Specifications".

### 5.3 Communication connections

#### Communication interface

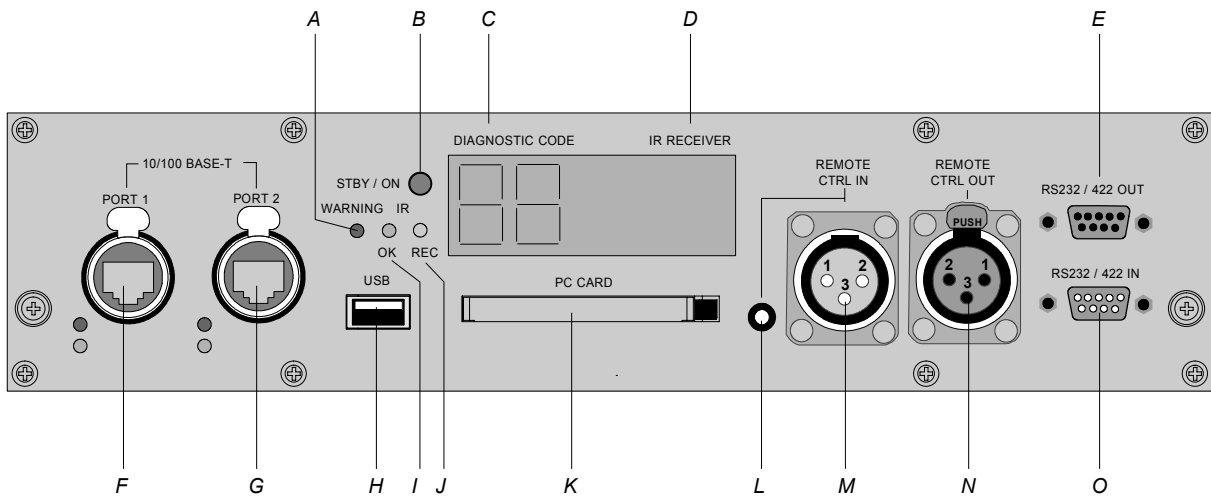

Image 5-11

- A Warning LED.
- B Projector status LED.
- C Two digit LED display for diagnostic code.
- D IR-receiver (side).
- E RS232/422 loop through output port.
- F Ethernet port 1.
- G Ethernet port 2.
- H USB port.
- I IR signal received LED.
- J IR signal acknowledged LED.
- K PCMCIA card-bus (slot).
- L Mini-jack input port for remote control.
- M XLR input port for remote control.
- N XLR output port for remote control.
- O RS232/422 input port.

#### Projector status

The projector "status" LED (B) lights up green while in operation. The same LED lights up red when the projector is switched to standby.

Besides the projector status LED (B) the communication interface has also a "warning" LED (A) which blinks in case the projector encounters an internal problem concerning fan speed, temperature, supply voltages, ... etc. These type of problems still allows the projector to operate (the show can go on) but an action will be required within a short time period. More information about the involved problem is given on the local LCD display of the projector.

A two character 7-segment display (C) shows, during normal operation, the selected input slot number. If an error has occurred then an error code appears on this two digit LED display.

#### IR communication (RC5)

An IR receiver (D) is mounted on the communication interface. Note that there is also an IR receiver mounted at the front and at the rear of the projector. When using the remote control unit (wired or wireless), the "IR REC" (I) and the "IR OK" (J) LED's will light up indicating an IR signal was received and recognized.

#### Wired remote control

If desired the remote control unit can be wired and plugged in into the 3,5 mm mini jack socket (L) or, when using a rugged wire with XLR plugs, plugged in into the male XLR port (M) on the communication interface. Besides the XLR input port a female XLR connector (N) for wired RC5 output is provided. This connector creates a buffered RC5 signal, available for the next projector in the daisy chain. Whenever the projector has no power, a passive loop through is created from the remote control input port to the

female XLR output port (N). So, the following projector in the daisy chain will still receive his RC5 code. Note that the RC5 in/out signals are without carrier.

| Mini jack plug |             | XLR – Remote CTRL in |                   | XLR – Remote CTRL out |                   |
|----------------|-------------|----------------------|-------------------|-----------------------|-------------------|
| Pin            | Description | Pin                  | Description       | Pin                   | Description       |
| S              | GND         | 1                    | GND               | 1                     | GND               |
| T              | RC5 in      | 2                    | RC5 in            | 2                     | RC5 out           |
| R              | n.c. or GND | 3                    | XLR present sense | 3                     | XLR present sense |

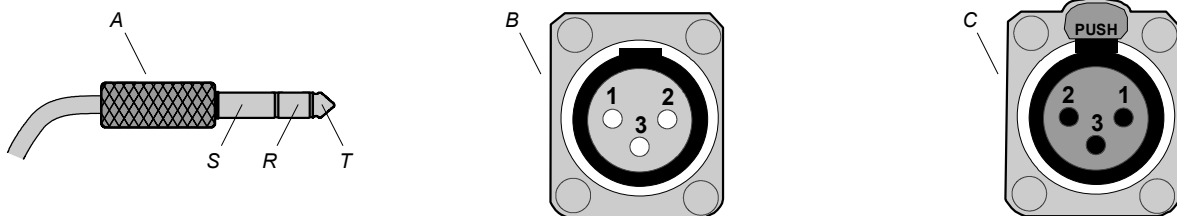

Image 5-12

A Mini stereo jack plug.

- S : Sleeve (shield)
- R : Ring
- T : Tip

B Male XLR socket.

C Female XLR socket.

### RS232/422 serial communication

The communication interface of the FLM HD20 supports RS232 and RS422 serial communication. You can use the RS232/RS422 input port (O) to connect a local PC to your FLM projector. This way you can configure and control your FLM projector from your local PC.



**Do not forget to set the projector's baud rate (default = 115200) to match that of the computer.**

The communication interface has also an active RS232/RS422 loop through output port (E). Whenever the projector has no power, a passive loop through is created from the RS232/RS422 input port (O) to the RS232/RS422 output port (E). So, the following projector in the daisy chain will still receive his RS232/RS422 commands.

Advantages of using RS232/RS422 serial communication:

- easy adjustment of the projector via PC (or MAC).
- allow storage of multiple projector configurations and set ups.
- wide range of control possibilities.
- address range from 0 to 255.
- sending data to the projector (update).
- copying data from the projector (backup).

| RS232/422 input port |  |
|----------------------|--|
| Pin                  | Description  |
| 1                    | DCD : Data Carrier Detect  |
| 2                    | RXD- : Receive Data  |
| 3                    | TXD- : Transmitted Data  |
| 4                    | DTR : Data Terminal Ready [RS232]<br>TXD+ : Transmitted Data [RS422] |
| 5                    | GND : Ground   |
| 6                    | DSR : Data Set Ready [RS232]<br>RXD+ : Received Data [RS422]         |
| 7                    | — (not connected) —  |

| RS232/422 output port |  |
|-----------------------|--|
| Pin                   | Description  |
| 1                     | — (not connected) —  |
| 2                     | RXD- : Receive Data  |
| 3                     | TXD- : Transmitted Data  |
| 4                     | DTR : Data Terminal Ready [RS232]<br>TXD+ : Transmitted Data [RS422] |
| 5                     | GND : Ground   |
| 6                     | DSR : Data Set Ready [RS232]<br>RXD+ : Received Data [RS422]         |
| 7                     | — (not connected) —  |

| RS232/422 input port |                     |
|----------------------|---------------------|
| Pin                  | Description         |
| 8                    | CTS : Clear To Send |
| 9                    | RI : Ring Indicator |

| RS232/422 output port |                     |
|-----------------------|---------------------|
| Pin                   | Description         |
| 8                     | — (not connected) — |
| 9                     | — (not connected) — |

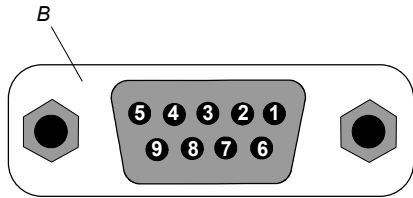
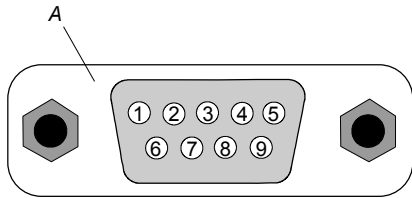

Image 5-13  
 A Pin numbering male DB-9 connector.  
 B Pin numbering female DB-9 connector.



**RS232**

An Electronic Industries Association (EIA) serial digital interface standard specifying the characteristics of the communication path between two devices using either D-SUB 9 pins or D-SUB 25 pins connectors. This standard is used for relatively short-range communications and does not specify balanced control lines. RS-232 is a serial control standard with a set number of conductors, data rate, word length and type of connector to be used. The standard specifies component connection standards with regard to computer interface. It is also called RS-232-C, which is the third version of the RS-232 standard, and is functionally identical to the CCITT V.24 standard. Logical '0' is > + 3V, Logical '1' is < - 3V. The range between -3V and +3V is the transition zone.



**RS422**

An EIA serial digital interface standard that specifies the electrical characteristics of balanced (differential) voltage, digital interface circuits. This standard is usable over longer distances than RS-232. This signal governs the asynchronous transmission of computer data at speeds of up to 920,000 bits per second. It is also used as the serial port standard for Macintosh computers. When the difference between the 2 lines is < - 0.2V that equals with a logical '0'. When the difference is > +0.2V that equals to a logical '1'.

**Ethernet network communication**

The FLM projector can be connected to a LAN (local area network) using port 1 (F) or port 2 (G) on the communication interface. Once connected to the LAN, users are capable of accessing the projector from any location, inside or outside (if allowed) their company network using the FLM control software: Projector Toolset. This toolset locates the projector on the network in case there is a DHCP server or the user can insert the correct IP-address of the projector to access the projector. Once accessed, it is possible to check and manipulate all the projector settings. Remote diagnostics, control and monitoring of the projector can then become a daily and very simple operation. The network connectivity permits to detect potential errors and consequently improve the time to servicing.

As there is a need to daisy chain projectors when they are in Ethernet network, an Ethernet switch is build in. the incoming network is hereby available for the internal PC and for the next device in the chain. In this way a 'star' network interconnection can be avoid. The switch used is a stand alone 10/100Mbit Ethernet switch. This assures no influence on the network speed. Whenever a slow (10Mbit) device is connected the speed between the 100Mbit devices remains 100Mbit.

Both Ethernet ports (F & G) are equipped with a yellow and green a LED. The yellow LED lights up in case the port is connected with a 100Mbit network. The green LED blinks in case there is network activity.



The connectors used for both Ethernet ports (F & G) are of rugged Neutrik EtherCon RJ45 type, which is compatible with standard RJ45 cable connector. Straight (most common) as well as cross linked network cables can be used. The 2 ports are functionally identical. Both ports are connected via the projector hub (Auto sensing enabled).

| 10/100 Base-T — RJ45 port |             |
|---------------------------|-------------|
| Pin                       | Description |
| 1                         | TXD+        |
| 2                         | TXD-        |
| 3                         | RXD+        |
| 4                         | —           |
| 5                         | —           |
| 6                         | RXD-        |



---

| 10/100 Base-T — RJ45 port |             |
|---------------------------|-------------|
| Pin                       | Description |
| 7                         | —           |
| 8                         | —           |

### USB port

The communication interface is equipped with a master USB port, type “A” connector (H). This USB port will simplify the service procedures for taking backup files from the projector without network connection. An USB-stick is plugged into the USB port and files can be transferred from or to the projector using the local or remote control unit. Note that the USB-stick has to be FAT16 compatible.

### Card bus connector (PCMCIA)

No cards supported yet.



## 6. GETTING STARTED

### About this chapter

This chapter describes the functions on the remote control and local keypad and gives an overview how to start up the projector. It gives also a brief overview of the direct adjustment possible with these controls.

### Overview

- RCU & Local keypad
- Terminology overview
- Operating the projector
- Using the RCU
- Quick setup adjustments
- Projector address
- Source selection
- Controlling the Projector

### 6.1 RCU & Local keypad

---

#### How controlling the projector ?

The projector can be controlled by the local keypad or by the remote control unit.

#### Location of the local keypad ?

The local keypad is located on the input side of the projector.

#### Remote control functions.

This remote control includes a battery powered infrared (IR) transmitter that allows the user to control the projector remotely. This remote control is used for source selection, control, adaptation and set up.

Other functions of the remote control are :

- switching between stand by and operational mode.
- switching to "pause" (blanked picture, full power for immediate restarting)
- direct access to all connected sources.

### 6.2 Terminology overview

---

#### Overview

The following table gives an overview of the different functionality of the keys.

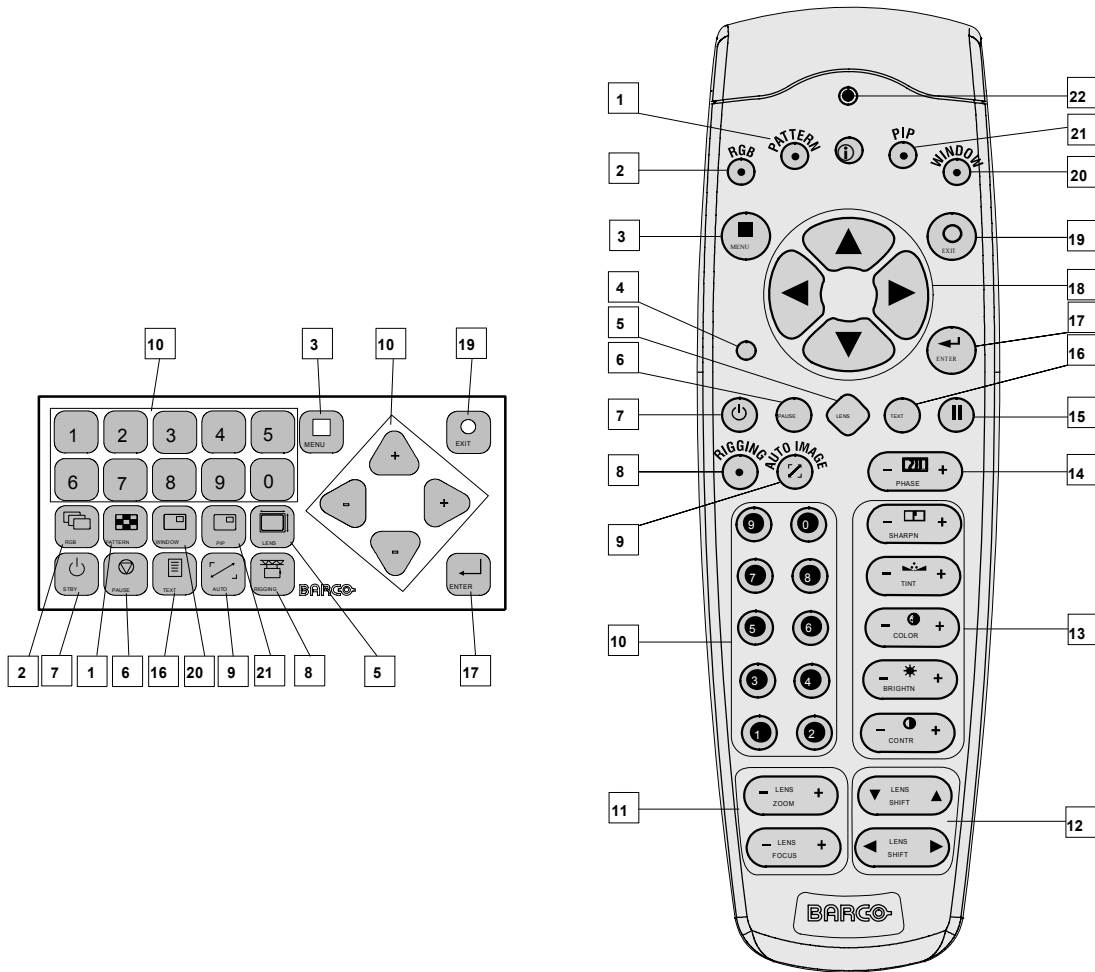

Image 6-1  
Local keypad & remote control

| Ind. | Key name         | Description   |
|------|------------------|---|
| 1    | Pattern key      | Direct access key to the internal pattern selection menu.<br>or when an on-screen menu was displayed, the pattern is displayed immediately.   |
| 2    | RGB              | Toggle key to enable and disable colors in the adjustment mode. Toggle between red, green, blue and full RGB.   |
| 3    | MENU             | Access key to the menu structure and key to quickly quit the adjustment menus.  |
| 4    | Address key      | (recessed key), to enter the address of the projector (between 0 and 9) in the remote control. Press the recessed address key with a pencil, followed by pressing one digit button between 0 and 9. |
| 5    | LENS             | Direct access key to the lens adjustment menus. Toggling this key will change the projected pattern.  |
| 6    | PAUSE            | To stop projection for a short time, press 'PAUSE'. The image disappears but full power is retained for immediate restarting. Shutter is closed.  |
| 7    | STBY             | Standby function switch off the lamp and lamp electronics. The lamp cooling fans remain active for about 5 minutes. The speed of the other fans is reduced.   |
| 8    | Rigging          | Direct access key to layout selection. Rigging key + sequence number opens directly the desired layout.   |
| 9    | Auto image       | Direct access key to automatically project the correct image.   |
| 10   | Digit buttons    | Direct input selection or menu short cuts or numeric entries  |
| 11   | Lens zoom/focus  | Zoom and focus controls of the lens   |
| 12   | Lens shift       | Shift control of the lens, to shift the lens up/down or left/right  |
| 13   | Picture controls | Use these buttons to obtain the desired picture level.  |

| Ind. | Key name                | Description  |
|------|-------------------------|--|
| 14   | PHASE                   | Used to remove the horizontal instability of the image (usually for RGB source). It adjusts the phase of the pixel sampling clock relative to the incoming signal.   |
| 15   | FREEZE                  | To freeze the actual projected image. Freeze sign is displayed in the upper left corner (a short press on the key).<br><br>When pressing for 5 sec, the projector goes into stand-by. The lamp cooling fans remain active for about 5 minutes. The speed of the other fans is reduced.   |
| 16   | TEXT                    | Toggle key to activate or deactivate on screen text boxes while adjusting a setting.<br><br>When adjusting one of the image controls, e.g.during a meeting, the normally displayed bar scale can be deactivated by pressing 'TEXT' key first. To re-display the bar scale on the screen, press 'TEXT' key again. When TEXT is 'off', no adjustment menu's will be displayed on the screen when entering the adjustment mode. All menus and adjustments remain active on the local LCD panel. |
| 17   | ENTER                   | Key to confirm an adjustment or selection in the adjustment mode.  |
| 18   | Cursor keys             | To make menu selections when in the adjustment mode  |
| 19   | EXIT                    | Key to go one menu stage higher than the actual position when in the adjustment mode.  |
| 20   | WINDOW                  | Selection of the active window, also in PIP mode.  |
| 21   | PIP                     | Direct access key for picture in picture selection.  |
| 22   | RC Operating indication | Lights up when a button on the remote control is pressed. (This is a visual indicator to check the operation of the remote control)  |

Table 6-1

## 6.3 Operating the projector

### Overview

- Switching on
- Errors, warnings and messages during start up
- Switching to standby
- Switching off

### 6.3.1 Switching on

#### How to switch on.

1. Press the power switch to switch on the projector.

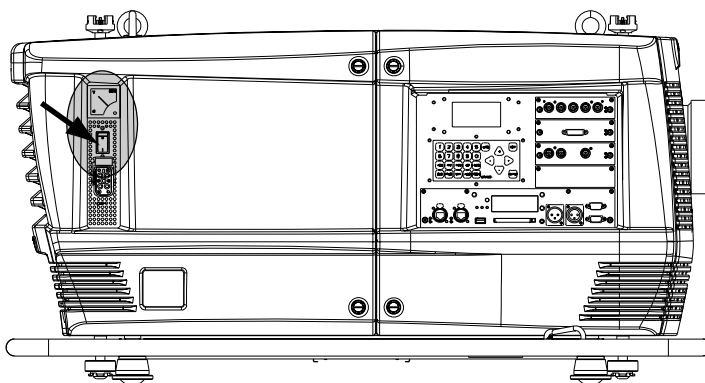
Image 6-2  
Switching on

- When '0' is visible, the projector is switched off.
- When '1' is visible, the projector is switched on.

The projector starts up in standby. The menus are accessible via the local LCD panel.

To display an image, the standby key must be pressed once.



The actual input voltage is indicated on the voltmeter just above the power switch.

### Starting image projection via the standby key.

1. Press **Stand by** key once on the local keypad or on the remote control.

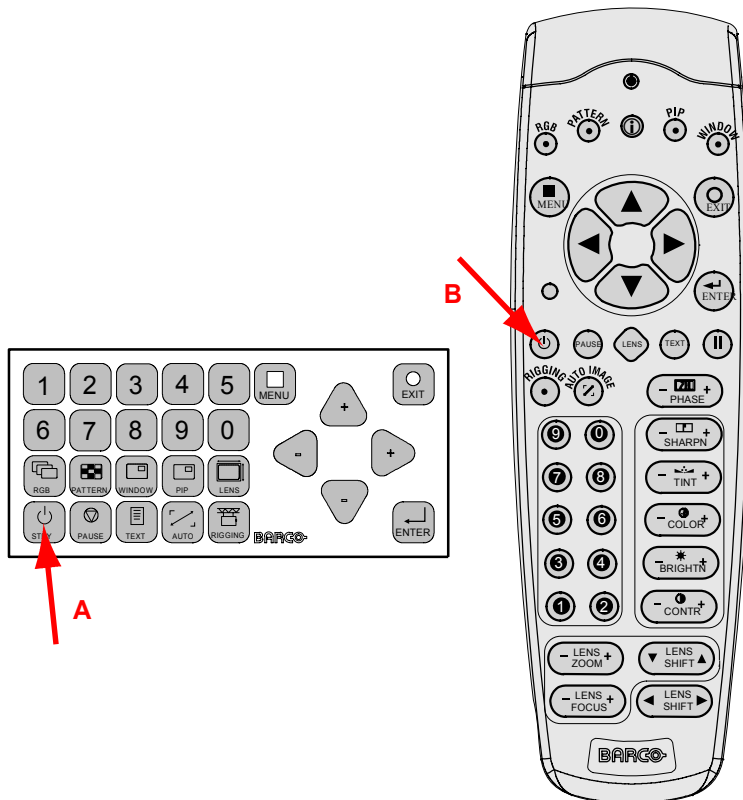

Image 6-3  
Stand by indication

- A Stand by indication on local keypad
- B Stand by indication on remote control

The projector status LED lights up.

The projector starts up on the last saved source.

Some lamp and runtime warnings can be displayed when an image is displayed after a start up.

### 6.3.2 Errors, warnings and messages during start up

#### Temperature error DMD

When the temperature of one of the DMD's is too low or too high the projector is switched automatically to standby. An error code will be displayed on the local LCD panel. For a list of possible error codes, see "Error codes", page 211.

### 6.3.3 Switching to standby

#### How to switch to standby?

1. Press **Standby** to switch the projector to standby.

A cool-down counter (after cooling) starts counting down for 5 minutes (only visible on the local LCD panel). During this period the fans are still running.

A restart is possible during this period.



**Switching to Standby.** When the projector is running and you want to go to standby, press the standby key for 2 seconds. Do not press any longer on the standby key otherwise the projector will restart.



All custom settings are written to the internal backup device. A message 'Save data ...' indicates this process. Never switch off the projector while this message is displayed.



When pressing for at least 5 seconds on the Freeze button, the projector goes to standby without the risk of restart..

### 6.3.4 Switching off

#### How to switch off the projector?

1. Press first **Standby**.
2. Let cool down the projector until the fans decrease, at least 5 min.
3. Switch off the projector with the power switch.



**CAUTION:** Never switch off the projector while the message 'Save data ...' is displayed !

## 6.4 Using the RCU

### Pointing to the reflective screen

1. Point the front of the RCU to the reflective screen surface.

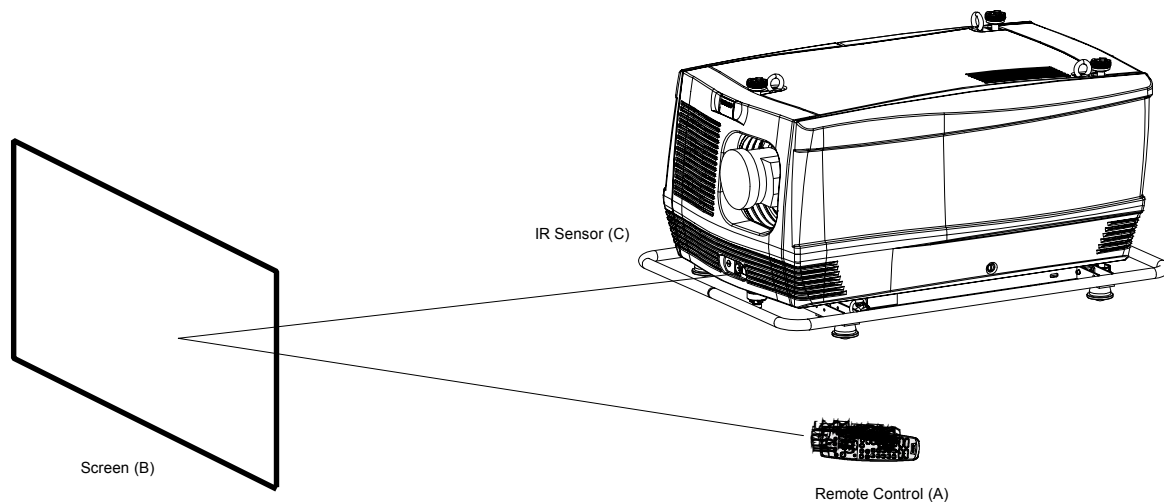

Image 6-4  
IR control via the reflective screen

- A Remote control
- B Screen
- C Front IR-sensor

### Hardwired Remote Input

1. Plug one end of the remote cable in the connector on the bottom of the RCU.

## 6. Getting started

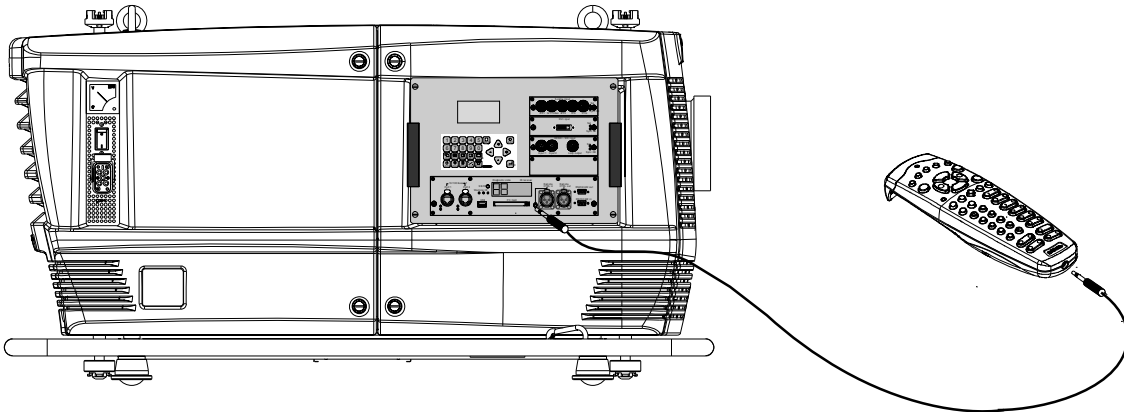

Image 6-5

2. Plug the other end in the small connector in the input panel of the projector labeled **Remote CTRL in**.



The Remote connection uses a standard two wire cable terminated on each end with a 3.5 mm male (mono/stereo) phone jack.

This cable is not delivered but is available in most electronic or audio shops.

### Hardwired to the XLR input

1. Plug one end of the remote cable in the connector on the bottom of the RCU
2. Plug the other end in the big connector in the input panel of the projector labelled **Remote CTRL in**.

### Directly to one of the IR sensors

When using the wireless remote control, make sure you are within the effective operating distance (30m, 100ft in a straight line). The remote control unit will not function properly if strong light strikes the sensor window or if there are obstacles between the remote control unit and the projector IR sensor.

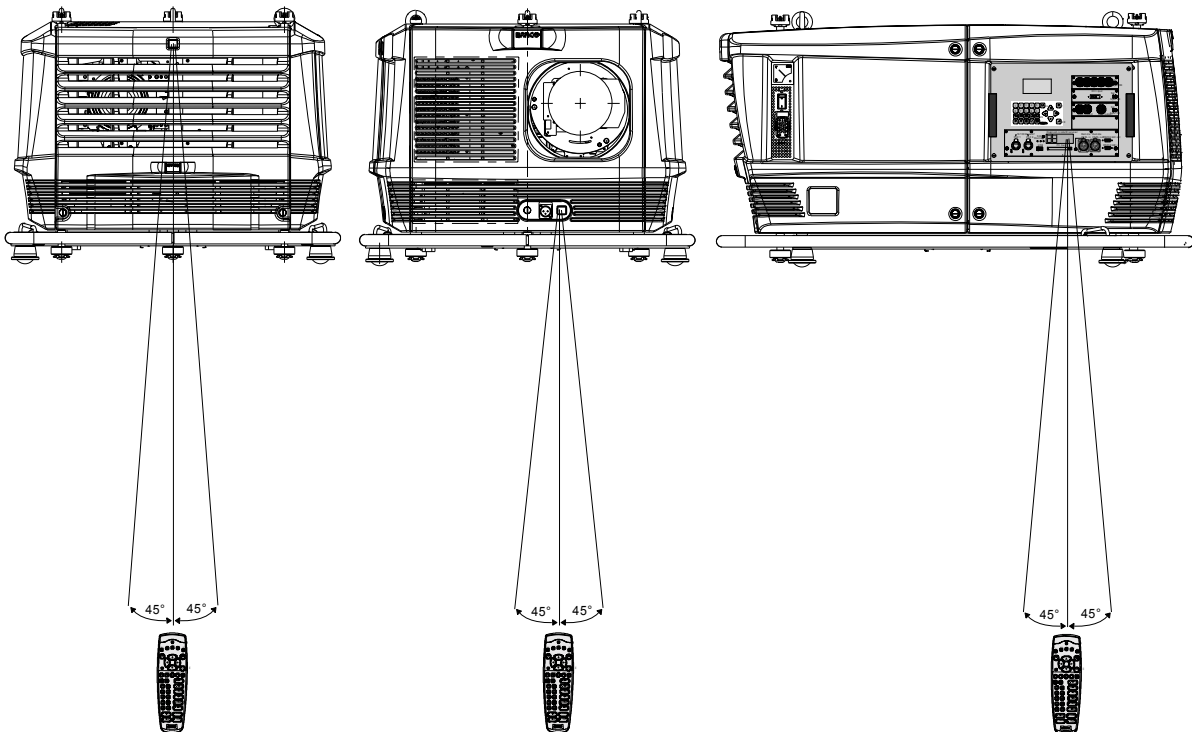

Image 6-6  
RCU to one of the IR sensors



## 6.5 Quick setup adjustments

### Overview

- Text boxes ON or OFF
- Quick Lens Adjustment
- Quick picture in picture
- Quick layout selection with Rigging key
- Quick language selection

### 6.5.1 Text boxes ON or OFF

#### Text toggle function

The on-screen text boxes can be switched OFF so that an adjustment during the operation of the projector are not visible on the screen. The adjustment indication remains visible on the local LCD screen.

To toggle Text ON or OFF, press the **TEXT** key on the remote control or local keypad.

### 6.5.2 Quick Lens Adjustment

#### 6.5.2.1 Quick Lens Adjustment via LENS key

##### Quick zoom/focus adjustment

1. Press the **LENS** key on the remote control or local keypad.

The zoom/focus menu will be displayed.

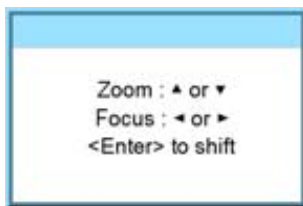

Image 6-7

2. Push the cursor key **▲** or **▼** to zoom and **◀** or **▶** to focus the image.
3. When finished, press **EXIT** key to return or **ENTER** to continue to the shift adjustment.



Press the **LENS** key to switch to another pattern. Different patterns are available.

##### Quick shift adjustment

1. Press the **LENS** key on the remote control or local keypad.

The zoom/focus menu will be displayed.

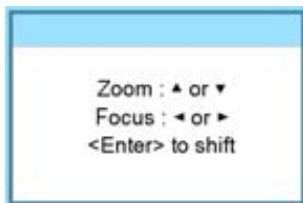

Image 6-8

2. Press **ENTER**.

## 6. Getting started

The shift menu will be displayed.



Image 6-9

3. Push the cursor key ▲ or ▼ to shift the image up or down and ◀ or ▶ to shift the image left or right.
4. When finished, press **EXIT** key to return or **ENTER** to continue to zoom/focus.



**Press the LENS key to switch to another pattern. Different patterns are available.**

### 6.5.2.2 Direct Lens Adjustment (RCU)

#### Lens adjustment buttons on the Remote Control

On the Remote Control four buttons with double action are provided, allowing direct alignment for lens ZOOM, FOCUS, HORIZONTAL SHIFT and VERTICAL SHIFT.

1. Press **LENS ZOOM** button [-] or [+] (A) for correct image size on the screen.

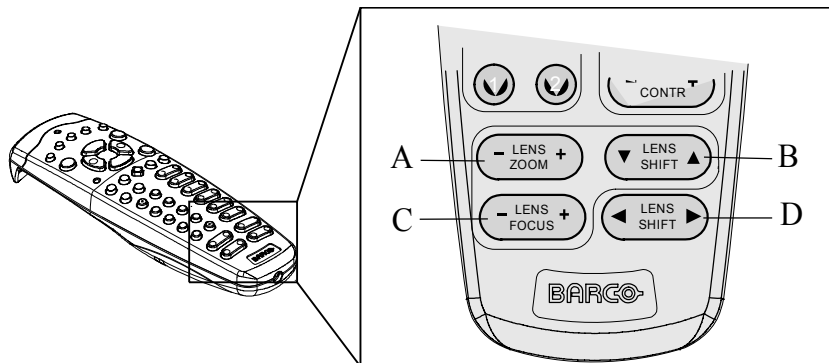

Image 6-10  
Direct lens adjustment keys

- A Zoom
- B Vertical shift
- C Focus
- D Horizontal shift

2. Press **LENS FOCUS** button [-] or [+] (C) for an overall focus of the image.
3. Press ▲ **LENS SHIFT** ▼ button for correct vertical position of the image on the screen.
4. Press ◀ **LENS SHIFT** ▶ button for correct horizontal position of the image on the screen.

### 6.5.3 Quick picture in picture

#### Quick On - Off

Press on the **PIP** key on the remote control or the local keypad to activate the Load layout window.

Use the ▲ ▼ key to scroll to the desired layout and press **ENTER** to activate.



**Select Main full screen to switch off PIP.**



Image 6-11

## 6.5.4 Quick layout selection with Rigging key

### What can be done ?

When the projector is playing, changing from one layout to another is possible without displaying any on screen selection menu. The current image is not disturbed as long no selection is made. Press the **Rigging** key followed by one or two digits to jump to a new layout.

When **Rigging** is pressed, an overview of the possible layouts with a sequence number is given on the local LCD panel. That sequence number is the number that should be pressed after Rigging is pressed to change the layout to the new selection.

### How to make a selection

1. Press **Rigging** followed by one or two digits and wait.

**Note:** *If you press only one digit, the projector wait a few time to check if a second digit will follow. If not, it switches to the selected layout.*

The selected layout is loaded.

Or,

press **Rigging**.

The layout selection menu is displayed on the local LCD panel.

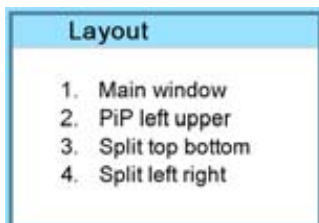

Image 6-12

2. Enter the digit or the two digits of your choice.

The selected layout is loaded.

Or,

scroll with the arrow keys to the desired layout and press **ENTER**.

The selected layout is loaded.



**When no digit is pressed after Rigging is pressed, the layout selection menu disappears after a few seconds without a layout change.**

## 6.5.5 Quick language selection

### Language selection

1. Press **Menu** to activate the menus and select with the ▲ or ▼ key Projector Control and press **ENTER**.
2. Select with the ▲ or ▼ key Language and press **ENTER**.

The language menu opens.

3. Select with the ▲ or ▼ key the desired language and press **ENTER** to activate.

## 6. Getting started

---

The current active language is indicated with an asterisk (\*).

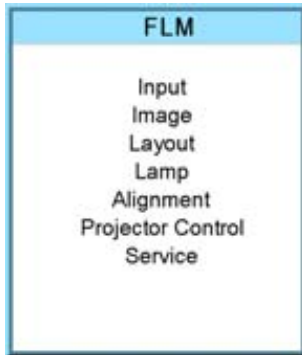

Image 6-13

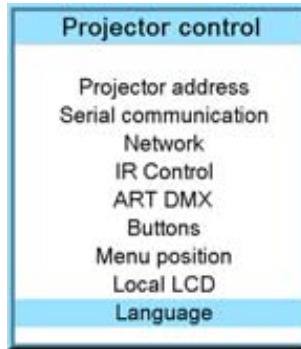

Image 6-14



Image 6-15

## 6.6 Projector address

---

### 6.6.1 Displaying and Programming addresses

#### Displaying the Projector Address on the Screen.

1. Press **Address** key (recessed key on the RCU) with a pencil.

The projector's address is displayed as first item in the Identification screen.



Image 6-16



To continue using the RCU with that specific address, it is necessary to enter the same address with the digit buttons (address between 0 and 9) within 5 seconds after pushing the address key. For example : if the Address key displays projector address 003, then press "3" digit button on the RCU to set the RCU's address to match the projector's address. Do not press 003 digits. This will address the remote control to '0' and control all projectors in the room. If the address is not entered within 5 seconds, the RCU returns to its default address (zero address) and control all projectors in the room.

#### How to Program an Address into the RCU?

1. Press the **Address** key (recessed key on the RCU) with a pencil.
2. Enter the address with the digit buttons within 5 seconds after pushing the address key.  
**Note:** That address can be any digit between 0 and 9.



The LED on the remote control must lit up while pressing a digit key. Otherwise the address is not entered in the remote control.

## 6.6.2 Controlling the projector



### Projector address

Address installed in the projector to be individually controlled.



### Common address

Projector will always execute the command coming from a RCU programmed with that common address.

### Why a projector address ?

As more than one projector can be installed in a room, each projector should be separately addressable with an RCU or computer. Therefore each projector has its own address.

### Set up an individual Projector Address.

The set up of a projector address can be done via the software. See chapter 'Projector Control', 'Projector address'.

### Projector controlling.

Every projector requires an individual address between 0 and 255 which can be set in the Service mode.

When the address is set, the projector can be controlled now:

- RCU for addresses between 0 and 9.
- computer, e.g. IBM PC (or compatible), Apple MAC, etc. for addresses between 0 and 255.

### Common Address

Every projector has a common address '0' or '1'. The choice between '0' and '1' can be selected in *Projector Control* → *Projector address* → *Common address*.

## 6.7 Source selection

### Source selection when no picture in picture is active

Use the digit keys on the remote control or local keypad to activate the desired source.

### Source selection when picture in picture is active

Use the **Window** button on the remote control or the local keypad to select the main window or the picture in picture (PiP) window.

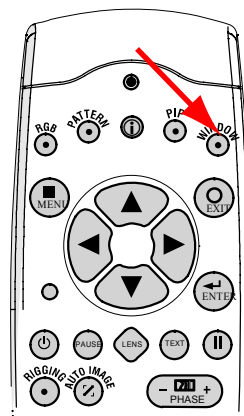
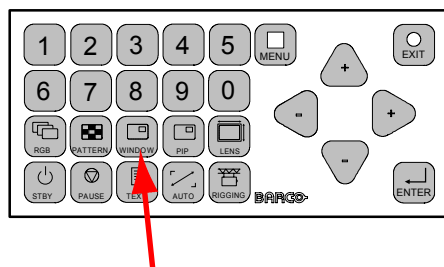

Image 6-17  
Window selection button

The outline of the selected window gets a colored rectangle to indicate the selection. For the main window, the color is blue. For the picture in picture window, the color is orange.

Once the desired window is activated (main window or picture in picture window) all keys on the remote control or local keypad can now control that selected window.

To select the source for the picture in picture window, press Window button until PiP window is activated and then select the desired source with the digit keys.

To select the source for the main window, press Window button until the main window is activated and then select the desired source with the digit keys.

## 6.8 Controlling the Projector

### Picture Controls

When an image control is pressed, a text box with a bar scale, icon and function name of the control, e.g. 'brightness...' appears on the screen (only if text is ON). See example screen. The length of the bar scale and the value of the numeric indication indicate the current memorized setting for this source. The bar scale changes as the control buttons on the RCU are pressed.

|            |   |
|------------|---|
| Brightness | A correct 'brightness' setting is important for good image reproduction.<br>Use the + button for a higher brightness.<br>Use the - button for a lower brightness.   |
| Contrast   | A correct 'contrast' setting is important for good image reproduction. Adjust the contrast to the level you prefer, according to room lighting conditions.<br>Use the + button for a higher contrast.<br>Use the - button for lower contrast. |
| Color      | Color saturation is only active for all type of video sources, such as Video, S-Video, SDI, HDSDI.<br>Adjust the color intensity of the picture.<br>Use the + button for richer colors.<br>Use the - button for lighter colors.               |
| Tint       | Tint is only active for Video and S-Video when using the NTSC 4.43 or NTSC 3.58 system.<br>Use the + button for more tint<br>Use the - button for less tint.  |
| Sharpness  | The sharpness function is used to adjust the image sharpness of video signals.<br>Use the + button for more sharpness<br>Use the - button for less sharpness  |
| Phase      | Use the + or - side of the phase control button to adjust the phase.  |

### The Pause Key

When the Pause key is pressed, the image projection is stopped, a black screen will be displayed and the projector remains with full power for immediate restart. The 7-segment display on the projector will show a "P". The shutter is closed.

To restart the image, press one of the following keys:

- Press **Pause** key.
- Select a source number.

### The Stand-by Key

When the Stand-by key is pressed, the image projection is stopped and the projector goes to stand-by. This situation is used when a projection stop is planned for a longer period. All custom settings are saved to an internal backup device. A message 'Save data ...' is displayed during this backup operation.

### The Freeze key

When pressing for 5 seconds on the Freeze button, the projector goes to stand-by. This function is very useful when multiple projectors have to be switched to stand-by. Set the RCU address to the common address and press Freeze for 5 seconds. All projectors go to stand-by without the risk of restart.

When pressing shortly on Freeze, the current image is frozen.

## 7. START UP OF THE ADJUSTMENT MODE

### Overview

- About the adjustment mode
- About the use of the remote control and the local keypad
- Start up the adjustment mode
- Navigation and adjustments
- On screen menus versus LCD display menus
- Test patterns in adjustment mode
- Menu memory

### 7.1 About the adjustment mode

---

#### Overview

As the adjustment mode is the central place to control and align the projector, the following functions can be done:

- Input setup: the different inputs can be configured for a specific format or input source.
- Image adjustment: these adjustments are organized per image source and contain the aspect ratio, timings and image settings.
- Layout adjustment: set up of the main window and the picture in picture window.
- Lamp: manage the lamp mode, the lamp use, lamp type and history
- Alignment: groups all controls necessary during the setup of the projector onto a screen.
- Projector control: contains the accessibility settings of the projector, such as address and communication setup.
- Service: contains information about how the projector is performing. This information will be useful when calling for a service intervention.

### 7.2 About the use of the remote control and the local keypad

---

#### Overview

All navigations and adjustments can be done either with the remote control or with the local keypad.

Almost all the keys on the remote control have an equivalent on the local keypad.

Exceptions:

- ▲ on the remote control corresponds with the up + key on the local keypad.
- ▼ on the remote control corresponds with the down - key on the local keypad.
- ◀ on the remote control corresponds with the left - key on the local keypad
- ▶ on the remote control corresponds with the right + key on the local keypad

### 7.3 Start up the adjustment mode

---

#### Start up tools

To start up the adjustment mode, use the remote control or the local keypad.

#### How to start up?

1. Press **Menu** on the remote control (RCU) or on the local keypad to start up the *Adjustment* mode.

## 7. Start up of the Adjustment Mode

---

The main menu of the adjustment mode opens.



Image 7-1

## 7.4 Navigation and adjustments

---

### How to navigate in the menu structure?

Once in the menu structure, use the **▲** or **▼** keys on the remote control (or the **▲** or **▼** (+ or -) key on the local keypad) to scroll through the items in the displayed menu. The selected item will get a background color. To activate a selected submenu or function, press **ENTER**.

When on a submenu, to return one step to the parent menu, press **EXIT**.

To escape the menu structure when on a menu, press **MENU**.

### How to make an adjustment?

With the remote control, press the **▲** or **▼** keys until the desired value (setup) is reached. Press **EXIT** to finalize the adjustment.

With the local keypad, press the **▲** or **▼** (+ or -) keys until the desired value (setup) is reached. Press **EXIT** to finalize the adjustment.

All adjustments will be indicated with an on-screen box with the name of the adjustment in the title bar, the length of the progress bar indicates the actual value. The value at the start and at the end of the progress bar indicates the adjustment ranges.

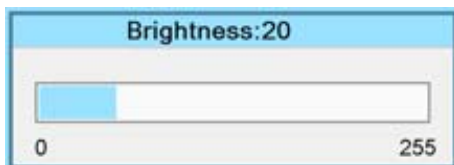

Image 7-2

While a bar scale is displayed, it is also possible to enter the desired value directly with the digit keys. Therefore, press **ENTER**. The menu changes to a *Enter new value* menu with the current value filled out. The first digit is selected.



Image 7-3

Use the **◀** or **▶** key to jump to the next digit or enter a new value for the selected digit with the digit keys and then the selection will jump also to the next digit. Repeat this action for all other digits and press **ENTER** to finalize the input.

If applicable in direct input, toggle between + and - with the left arrow key (**◀**).

## 7.5 On screen menus versus LCD display menus

---

### Overview

As the projector is equipped with an 8 lines LCD panel, the on-screen menus are also displayed on that LCD panel in the same structure as the on screen menus. These menus can be used in the same way as the on-screen menus.

The menus on the LCD panel are still reachable even when the projector lamp is not activated and when Text is in the off mode.



When quitting the menu structure, the backlighting of the LCD panel is switched off after a few seconds.

## 7.6 Test patterns in adjustment mode

---

### Overview

When the adjustment mode is started, a test pattern can be called at any moment just by pressing the **Pattern** key on the RCU or the local key path. Press as many times on the **Pattern** key as necessary to display the desired test pattern. The test pattern remains on the screen as long as the adjustment mode is selected, even when selecting other menus. When leaving the adjustment mode, the selected test pattern is cleared and the normal image is displayed again.

## 7.7 Menu memory

---

### Overview

Each menu with sub menus, remembers its last selected sub item even when leaving the menu structure and that as long as the projector is running. When restarting the projector from stand-by, the menu memory is reset.

After re-opening the main menu and selecting an item, the previous selected sub item of that selected item is highlighted and can be opened just by pressing **ENTER**.



## 8. INPUT MENU

### Overview

- Overview flow
- Slot module type
- Input locking
- Minimum delay
- Native resolution
- Source switching
- No signal

### 8.1 Overview flow

#### Overview

| Level 1 | Level 2                    | Level 3  |
|---------|----------------------------|--|
| Input   |                            |  |
|         | Slot module type           | 5-cable<br>HD-SDI - SDI<br>DVI<br>DVI HDCP               |
|         | Input locking              | Free running<br>Automatic<br>Input 1 to 4                |
|         | Minimum delay [On/Off]     |  |
|         | Native resolution [On/Off] |  |
|         | Source switching           | Effect<br>Effect time                                    |
|         | No signal                  | Color [black/blue]<br>Shutdown [Off/On]<br>Shutdown time |

### 8.2 Slot module type

#### Overview

- About Input Setup
- Input configuration

#### 8.2.1 About Input Setup

##### Overview

Each input module must be configured before these module can be used. This configuration is necessary so that the projector knows which type of signal is connected to its input.

The projector has 4 input slots and these slots can be filled up in a random order with the available modules. Identical modules are allowed.

For more information about the available input modules and how to install, see "Input source connections", page 37.



**CAUTION:** Always install a cover plate on an unused input slot. This to prevent dust intrusion into the projector.

## 8.2.2 Input configuration

### How to change?

1. Press **MENU** to activate the menus.
2. Use the **▲** or **▼** key to select *Input* and press **ENTER**.  
The Input menu is displayed.
3. Use the **▲** or **▼** key to select *Slot module type* and press **ENTER**.  
The slot overview window is displayed with the actual situation filled out.
4. Use the **▲** or **▼** key to select a slot.  
Press **ENTER** to open the selection menu which will be different from input type to input type (except for DVI, see DVI equalization).

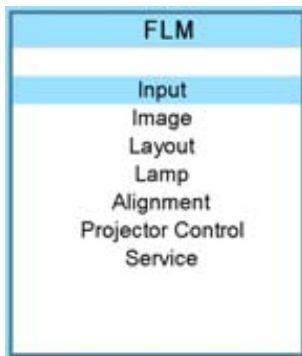

Image 8-1

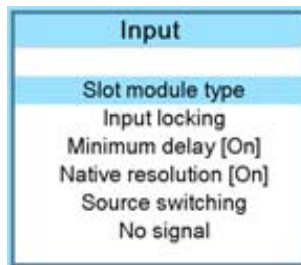

Image 8-2

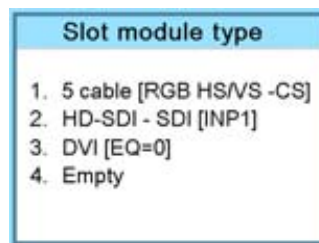

Image 8-3

### For a 5 cable module

When **ENTER** is pressed on a 5 cable module, the following menu appears:



Image 8-4

Use the **▲** or **▼** key to select the desired configuration and press **ENTER** to select.

When e.g. RGB AUTO is selected, the projector discovers itself which type of RGB signal is connected to it and loads the correct settings.

For RGB selections, advanced settings are possible. To adjust these advanced settings, use the **▲** or **▼** key to select *Advanced settings* and press **ENTER**. The advanced settings menu opens:

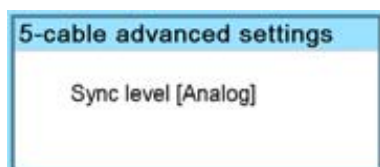

Image 8-5

Press **ENTER** to toggle between [Analog] and [TTL].

### For a HDSI - SDI module

When **ENTER** is pressed on a HDSI or SDI module, the following menu appears:

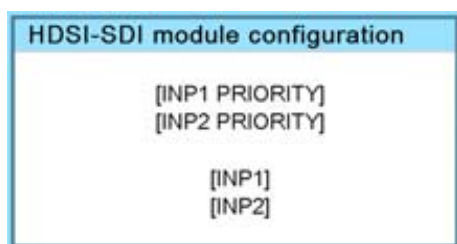

Image 8-6

Use the **▲** or **▼** key to select the desired configuration and press **ENTER** to select.

When an input with priority is selected, then if a signal is connected to both inputs the input indicated has the priority. If there is no signal on the priority input, the signal of the other input is displayed.

### DVI equalization

When a DVI module (DVI or DVI HDCP) is selected, press **ENTER** to go in edit mode. Use **◀** or **▶** to key to change the equalization value.

Default value = 13.

For non DVI-compliant transmitter, stronger equalization may be necessary even for shorter cables.

For longer cables adjust between 0 and 13 (more equalization).

For shorter cables adjust between 13 and 15 (least equalization).

## 8.3 Input locking

### What is possible?

The output signal can be locked on an internal sync signal or on the sync signal of one of the input sources. Input locking can avoid that some windows in the output signal are slowly moving or trembling.

When automatic is selected, the lock will be set on the input signal of the main window.

### How to set up?

1. Press **MENU** to activate the menus.
2. Use the **▲** or **▼** key to select *Input* and press **ENTER**.  
The Input menu is displayed.
3. Use the **▲** or **▼** key to select *Input locking* and press **ENTER**.  
The input locking window is displayed. The actual selected locking method is indicated by an arrow.
4. Use the **▲** or **▼** key to select the desired locking and press **ENTER**.

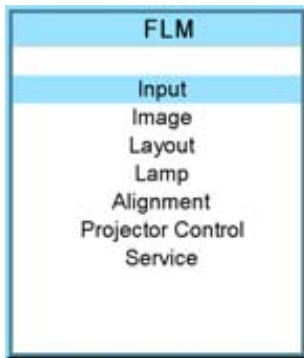

Image 8-7

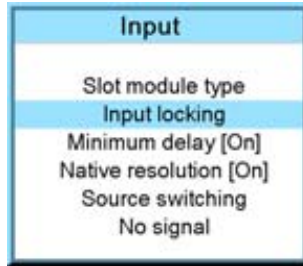

Image 8-8

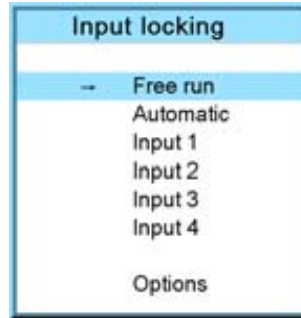

Image 8-9

When:

|           |  |
|-----------|--|
| Free run  | Output is locked on an internal sync (60 Hz)               |
| Automatic | Output is locked on the selected input for the main window |
| Input 1   | Output is locked on source 1                               |
| Input 2   | Output is locked on source 2                               |
| Input 3   | Output is locked on source 3                               |
| Input 4   | Output is locked on source 4                               |

The options menu changes depending on the selection.



When Input locking is set to Automatic or on a specific input and there is no sync signal available, the locking will be switched to Free run without changing the user settings. Once the sync is available, it applies again the user settings.

### Options for Free run

When *Free run* is selected (arrow in front of it) and then the *Options* are selected, the following menu appears:

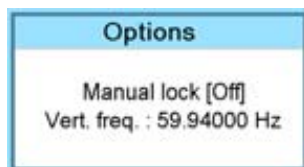

Image 8-10

Use the ▲ or ▼ key to select *Manual lock* and press **ENTER** to toggle between *On* and *Off*.

Manual lock on : locking is done on the indicated vertical frequency which can be changed by the user.

Manual lock off : locking is done on an internal sync (60 Hz).

To change the locking frequency for manual lock on, use the ▲ or ▼ key to select *Vert freq* and press **ENTER** to activate. The first digit is selected.

Use the ▲ or ▼ key to select the desired digit and press ◀ or ▶ key to select the next digit in the address or enter the value with the digit keys on the remote control or local keypad. The next digit in the value will be automatically selected.

### Options for Automatic or specific input

When *Automatic* or specific input is selected (arrow in front of it) and then the *Options* are selected, the following menu appears:

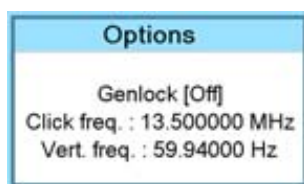

Image 8-11

Use the ▲ or ▼ key to select *Genlock* and press **ENTER** to toggle between *On* and *Off*.

- Genlock off (default position) locking done on input source of main window, when automatic was selected or on the selected input source when a specific input was selected. Projector detects automatically the vertical frequency and clock frequency of the input signal. A slightly difference with the source is possible.
- Genlock on locking done on indicated vertical frequency and clock frequency. This vertical frequency and clock frequency must be exactly the same as those of the source.
- Only use genlock ON for very stable sources and preferable for broadcast sources.

For Genlock on,

to change the locking frequency, use the ▲ or ▼ key to select *Vert freq* and press **ENTER** to activate. The first digit is selected.

Use the ▲ or ▼ key to select the desired digit and press ◀ or ▶ key to select the next digit in the address or enter the value with the digit keys on the remote control or local keypad. The next digit in the value will be automatically selected.

to change the clock frequency, use the ▲ or ▼ key to select *Clock freq* and press **ENTER** to activate. The first digit is selected.

Use the ▲ or ▼ key to select the desired digit and press ◀ or ▶ key to select the next digit in the address or enter the value with the digit keys on the remote control or local keypad. The next digit in the value will be automatically selected.



**For older custom files, created with software packages older than package 1.5.6, the Genlock function will be grayed out. If you want to use this genlock function, a new custom file must be created starting from the standard file. Copying the custom file in a new file do not solve this issue.**

## 8.4 Minimum delay

### Purpose

In normal mode, the processing (scaling and de-interlacing) in DLP projectors introduces a few frames delay (from input to screen). Setting the option *Minimum Delay* to "ON" disables all scaling and de-interlacing in the processing and reduces frame delay of the projector (from input to screen) to ONE frame, caused by the formatter board (DLP technology restriction). The intended use of this option is to apply native and progressive data to the projector and displaying it with minimum delay, using the full resolution of the projector. Other formats will be displayed either unscaled and/or interlaced.

This feature can be used if additional delay in the projector is not acceptable. For instance if a projector is showing the DVI loop out of another DLP or if an external scaler/de-interlacer does the processing.

### How to toggle the delay?

1. Press **MENU** to activate the menus.
2. Use the ▲ or ▼ key to select *Input* and press **ENTER**.  
The Input menu is displayed.
3. Use the ▲ or ▼ key to select *Minimum delay* and press **ENTER** to toggle between [On] and [Off].

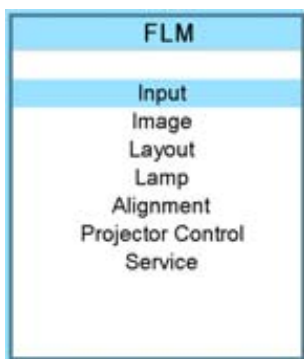

Image 8-12

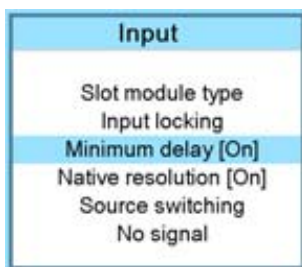

Image 8-13

## 8.5 Native resolution

### What can be done

The aim here is to always show the resolution of the source independently of the resolution of the DMD panels.

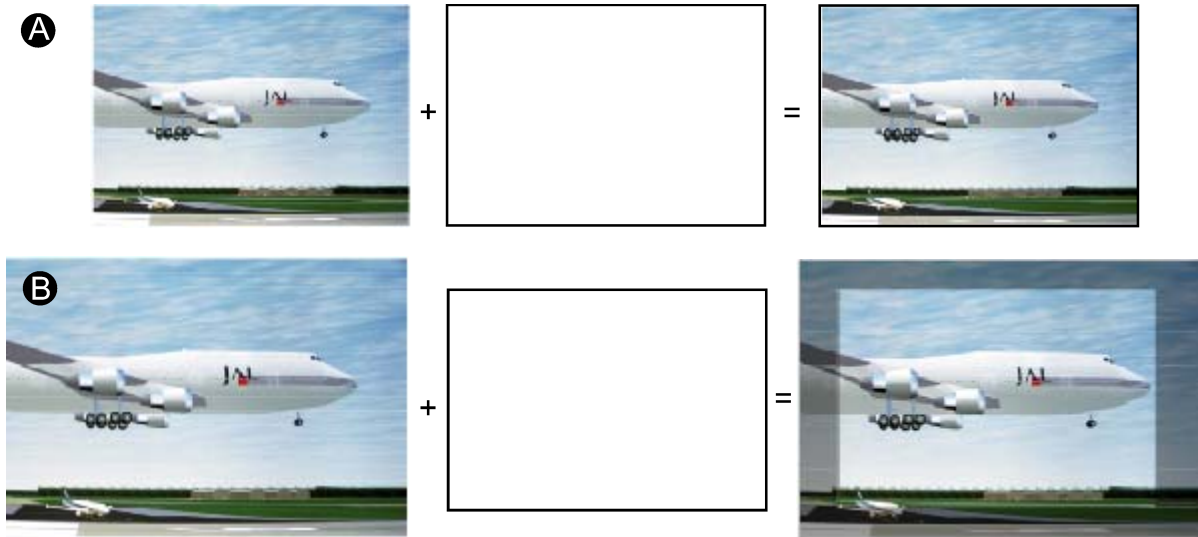

Image 8-14

When the *show native resolution* function is in the ON position, the projector handles the source as follows:

| Source |       |            | Projected image |            |   |
|--------|-------|------------|-----------------|------------|---|
| Name   | Ratio | Resolution | Ratio           | Resolution |   |
| XGA    | 4:3   | 1024x768   | 4:3             | 1024x768   | image projected with black borders  |
| SXGA   | 5:4   | 1280x1024  | 5:4             | 1280x1024  | image projected with black borders  |
| SXGA+  | 4:3   | 1400x1050  | 4:3             | 1400x1050  | image projected with black borders  |
| UXGA   | 4:3   | 1600x1200  | 4:3             | 1600x1200  | part of the image displayed, image scroll possible<br>Black borders left and right. |
|        | 16:9  | 1920x1080  | 16:9            | 1920x1080  | normal image projected  |

**How to toggle to native resolution?**

1. Press **MENU** to activate the menus.
2. Use the **▲** or **▼** key to select *Input* and press **ENTER**.  
The Input menu is displayed.
3. Use the **▲** or **▼** key to select *Native resolution* and press **ENTER** to toggle between [On] and [Off].  
[On] : images displayed in native resolution  
[Off] : images scaled to fill the complete screen

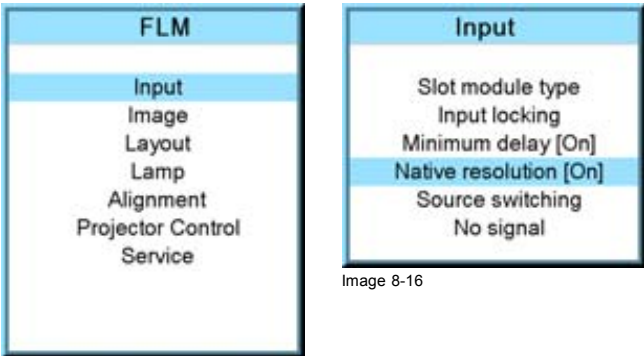

Image 8-16

Image 8-15





When native resolution is on, some other menus such as *Aspect ratio*, *timings* are greyed out.

## 8.6 Source switching

### Switching from one source to another

To minimize undesired effects when switching from one source to another one can use the switching mode, using the fade effect.



Image 8-17  
Example of fade effect

### Switching mode set up

1. Press **MENU** to activate the menus.
2. Use the **▲** or **▼** key to select *Input* and press **ENTER**.  
The Input menu is displayed.
3. Use the **▲** or **▼** key to select *Source switching* and press **ENTER**.  
The Source switching menu is displayed.
4. Use the **▲** or **▼** key to select *Effect* and press **ENTER** to toggle between *No transition* and *Fade*.  

|               |   |
|---------------|---|
| No transition | No source switching effect is activated.                              |
| Fade          | Fade in, fade out effect is activated. Transition time can be set up. |
5. Use the **▲** or **▼** key to select *Effect time* and press **ENTER**.
6. Enter the desired time with the digit keys  
Or,  
use the **▲** or **▼** key to scroll until the desired time is reached. Press **ENTER** to activate.

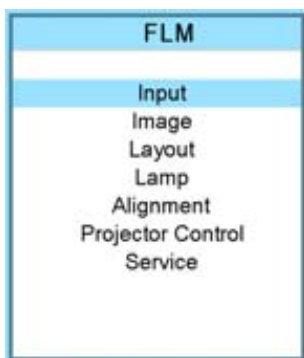

Image 8-18

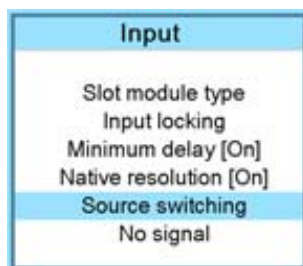

Image 8-19

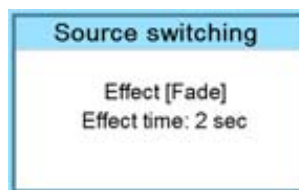

Image 8-20

## 8.7 No signal

### Overview

- Background color
- Shutdown setting
- Shutdown retarding time

### What can happen when no signal

When no signal available, a blue or black background color can be displayed or the projector can be shutdown with a certain retarding time.

#### 8.7.1 Background color

##### How to change the color

1. Press **MENU** to activate the menus.
2. Use the **▲** or **▼** key to select *Input* and press **ENTER**.  
The Input menu is displayed.
3. Use the **▲** or **▼** key to select *No signal* and press **ENTER** to toggle between [Black] and [Blue].

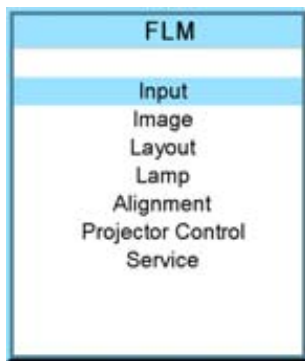

Image 8-21

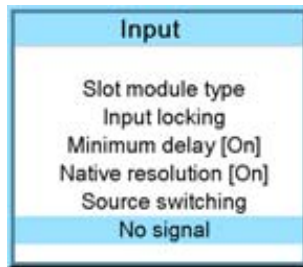

Image 8-22



Image 8-23

#### 8.7.2 Shutdown setting

##### How to change the shutdown setting

1. Press **MENU** to activate the menus.
2. Use the **▲** or **▼** key to select *Input* and press **ENTER**.  
The Input menu is displayed.
3. Use the **▲** or **▼** key to select *Shutdown* and press **ENTER** to toggle between [On] and [Off].

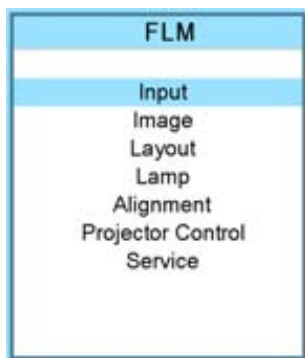

Image 8-24

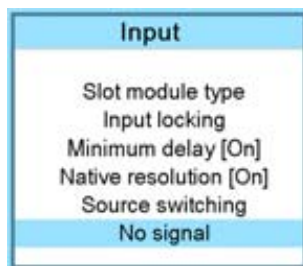

Image 8-25



Image 8-26

#### 8.7.3 Shutdown retarding time



Only accessible when *Shutdown* is set to [On].

##### How to set the retarding time?

1. Press **MENU** to activate the menus.
2. Use the **▲** or **▼** key to select *Input* and press **ENTER**.

The Input menu is displayed.

- Use the ▲ or ▼ key to select *Shutdown time* and press **ENTER**.
- Use the ▲ or ▼ key to change the value.  
Or,  
enter the desired value with the keyboard.

When trying to exceed the maximum allowed value, the system will set it back to the maximum value.

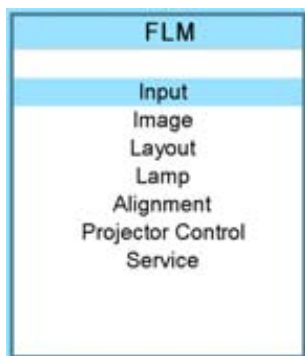

Image 8-27

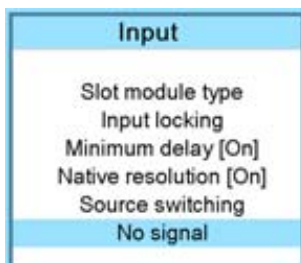

Image 8-28



Image 8-29



## 9. IMAGE MENU

### Overview

- Overview flow
- How to select the image adjustments?
- Image Settings
- Aspect ratio
- Timings
- Image files services
- Save custom settings

### 9.1 Overview flow

#### Overview



## 9. Image menu

---

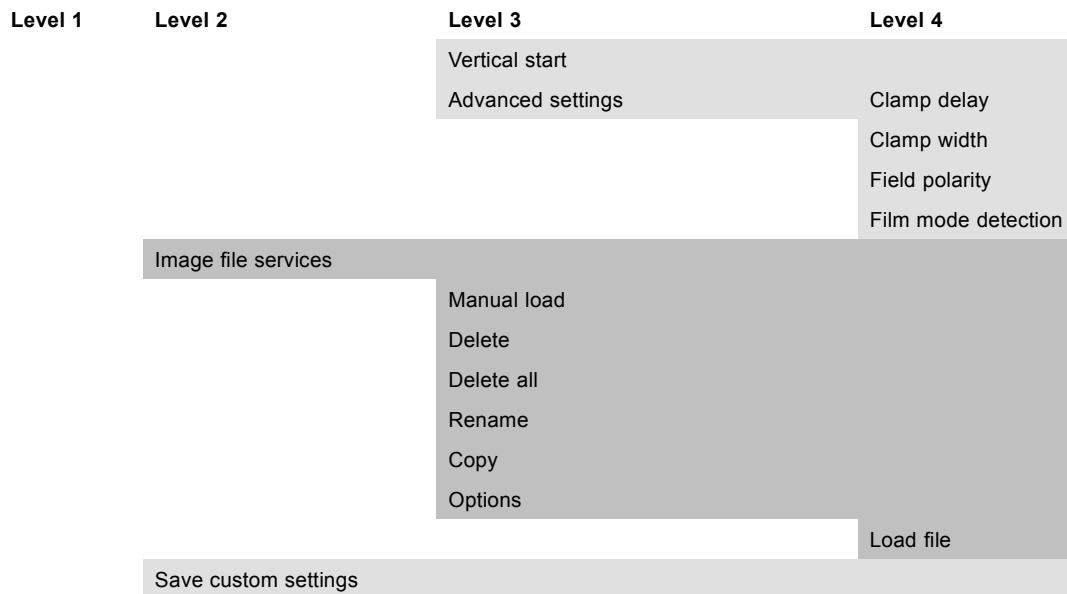

## 9.2 How to select the image adjustments?

---

### Start up

1. Use the ▲ or ▼ key to select *Image*.
2. Press **ENTER** to select.

The *Image* menu opens.

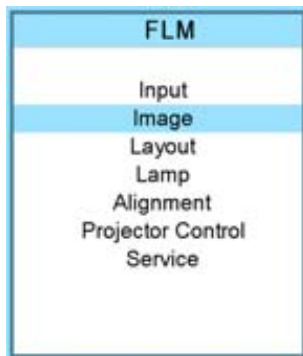

Image 9-1



Image 9-2

## 9.3 Image Settings

---

### Overview

- Contrast
- Brightness
- Saturation
- Tint (hue)
- Phase
- Sharpness
- Noise reduction
- Color temperature
- Input balance

### 9.3.1 Contrast

#### About Contrast

The contrast function is used to adjust the contrast between the light and dark areas of the displayed image.

#### How to change the contrast?

1. Press **MENU** to activate the menus.
2. Use the **▲** or **▼** key to select *Image* and press **ENTER**.
3. Use the **▲** or **▼** key to select *Image settings* and press **ENTER**.
4. Use the **▲** or **▼** key to select *Contrast* and press **ENTER**.

The Contrast progress bar appears.

5. Use **◀** or **▶** to change the contrast.

The higher the value, the higher the contrast.

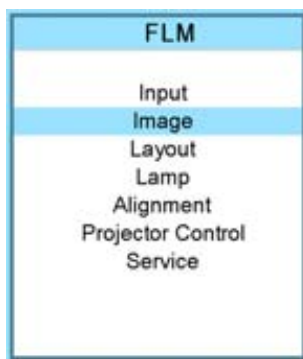

Image 9-3



Image 9-4

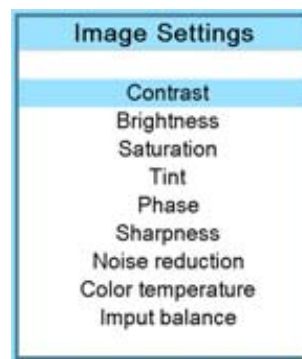

Image 9-5

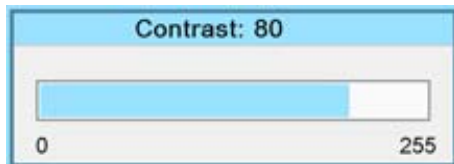

Image 9-6

### 9.3.2 Brightness

#### About Brightness

The Brightness function is used to adjust the overall light output.

#### How to change the brightness?

1. Press **MENU** to activate the menus.
2. Use the **▲** or **▼** key to select *Image* and press **ENTER**.
3. Use the **▲** or **▼** key to select *Image settings* and press **ENTER**.
4. Use the **▲** or **▼** key to select *Brightness* and press **ENTER**.

The Brightness progress bar appears.

5. Use **◀** or **▶** to change the brightness.

## 9. Image menu

The higher the value, the higher the brightness.

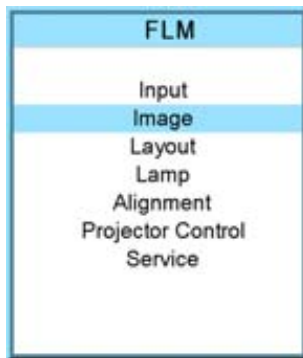

Image 9-7



Image 9-8

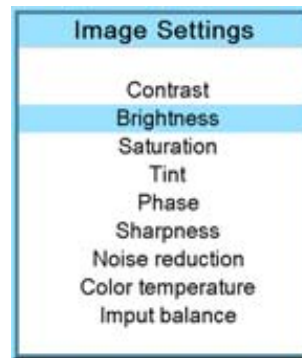

Image 9-9

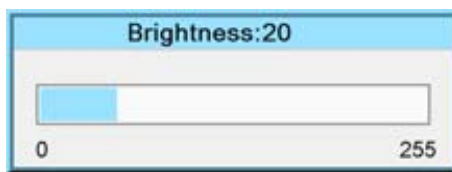

Image 9-10

### 9.3.3 Saturation

#### About (color) saturation

The color function is used to adjust the color saturation levels.

#### How to change the saturation?

1. Press **MENU** to activate the menus.
2. Use the **▲** or **▼** key to select *Image* and press **ENTER**.
3. Use the **▲** or **▼** key to select *Image settings* and press **ENTER**.
4. Use the **▲** or **▼** key to select *Saturation* and press **ENTER**.

The Saturation progress bar appears.

5. Use **◀** or **▶** to change the color saturation.

The higher the value, the higher the color saturation.

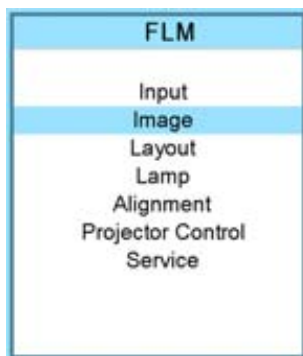

Image 9-11



Image 9-12

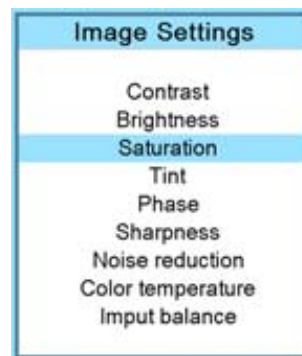

Image 9-13

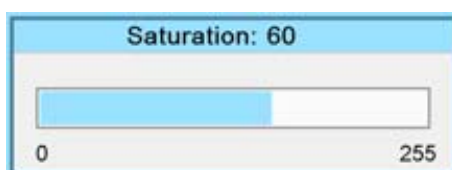

Image 9-14



### 9.3.4 Tint (hue)

#### About Tint

The Tint function is used to adjust color hue to obtain true color reproduction and is only active for Video and S-Video when the NTSC color system is used. For PAL and SECAM sources, Tint is not accessible.

#### How to change the saturation?

1. Press **MENU** to activate the menus.
2. Use the **▲** or **▼** key to select *Image* and press **ENTER**.
3. Use the **▲** or **▼** key to select *Image settings* and press **ENTER**.
4. Use the **▲** or **▼** key to select *Tint* and press **ENTER**.

The Tint progress bar appears.

5. Use **◀** or **▶** to change the tint.

The higher the value, the higher the tint.

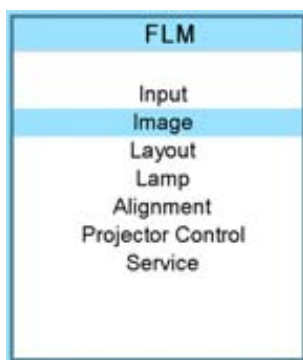

Image 9-15



Image 9-16

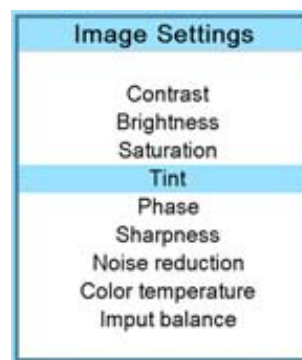

Image 9-17

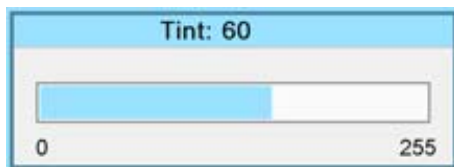
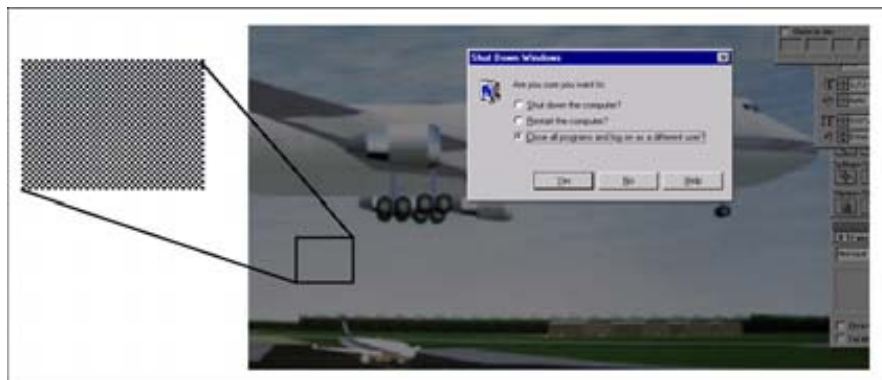

Image 9-18

### 9.3.5 Phase

#### About Phase adjustment

When displaying computer patterns or graphics (RGB or YUV signals) which are very detailed (tilting, vertical stripes, etc. ), jitter in picture (mis-sampling) may occur, causing horizontal stripes in portions of the screen. When this jitter occurs, adjust 'Phase' for optimum image.

Image 9-19  
Jittering on image

### How to change the phase?

1. Press **MENU** to activate the menus.
2. Use the **▲** or **▼** key to select *Image* and press **ENTER**.
3. Use the **▲** or **▼** key to select *Image settings* and press **ENTER**.
4. Use the **▲** or **▼** key to select *Phase* and press **ENTER**.

The Phase progress bar appears.

5. Use **◀** or **▶** to change the phase and refine the jitter.

**Note:** Don't mix up with wrong number of total pixels. If the jitter doesn't disappear with the phase adjustment, check the total number of pixels. (Best image = pixel on pixel off pattern. For example: shut down screen of a PC)

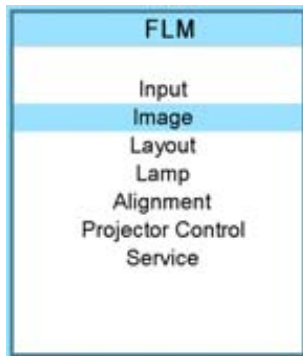

Image 9-20



Image 9-21

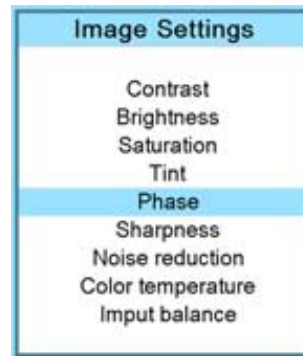

Image 9-22

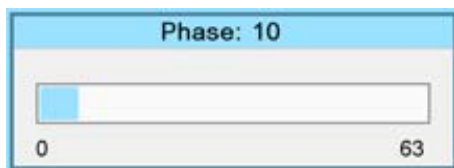

Image 9-23

### 9.3.6 Sharpness

#### About Sharpness

The sharpness function is used to adjust the image sharpness of video signals.

#### How to change the sharpness?

1. Press **MENU** to activate the menus.
2. Use the **▲** or **▼** key to select *Image* and press **ENTER**.
3. Use the **▲** or **▼** key to select *Image settings* and press **ENTER**.
4. Use the **▲** or **▼** key to select *Sharpness* and press **ENTER**.

The Sharpness progress bar appears.

5. Use **◀** or **▶** to change the sharpness.

The higher the value, the higher the sharpness.

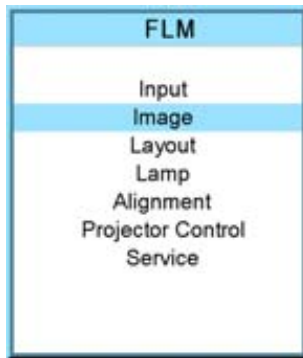

Image 9-24



Image 9-25

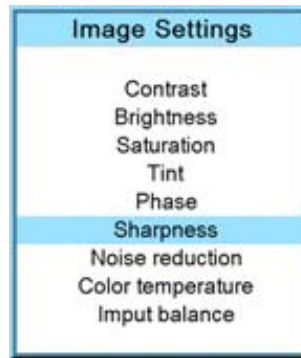

Image 9-26

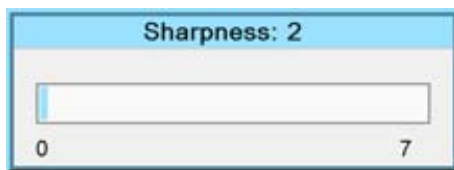

Image 9-27

### 9.3.7 Noise reduction

#### About Noise reduction

Reduces noise and pixel jitter in all video sources.

#### How to change?

1. Press **MENU** to activate the menus.
2. Use the **▲** or **▼** key to select *Image* and press **ENTER**.
3. Use the **▲** or **▼** key to select *Image settings* and press **ENTER**.
4. Use the **▲** or **▼** key to select *Noise reduction* and press **ENTER**.

The Noise reduction progress bar appears.

5. Use **◀** or **▶** to change the noise reduction.

The higher the value, the higher the noise reduction.

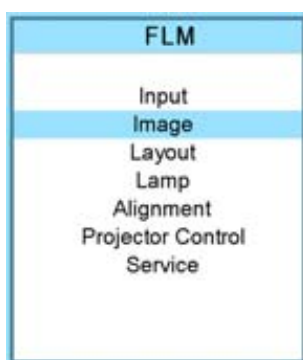

Image 9-28



Image 9-29

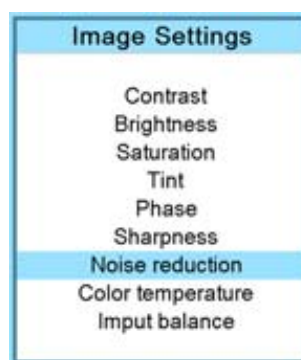

Image 9-30

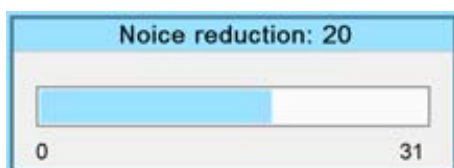

Image 9-31

### 9.3.8 Color temperature

#### What can be done ?

The color temperature can be selected according to the type of source:

There are 5 different preset color temperatures:

- Projector white
- computer : 9300 K
- Video : 6500 K
- Film : 5400 K
- Broadcast : 3200 K

These calibrated presets can be selected and will provide optimum color tracking, the projector allows however the setting of a personal color temperature, this is done in *custom balance*



Color temperature selection is only possible when Color space is OFF



#### Color temperature

The coloration (reddish, white, bluish, greenish, etc.) of white in an image, measured using the Kelvin (degrees K) temperature scale. Higher temperatures output more light.

#### 9.3.8.1 Predefined color temperature



Projector white will provide maximum projector light output. The calibrated 'Broadcast', 'Film', 'Video' and 'Computer' presets will provide optimum color tracking.

#### How to select?

1. Press **MENU** to activate the menus.
2. Use the **▲** or **▼** key to select *Image* and press **ENTER**.
3. Use the **▲** or **▼** key to select *Image settings* and press **ENTER**.
4. Use the **▲** or **▼** key to select *Color temperature* and press **ENTER**.
5. Use the **▲** or **▼** key to select a predefined color temperature value, e.g. Video, and press **ENTER**.

The colors of the image is switched to the selected value.

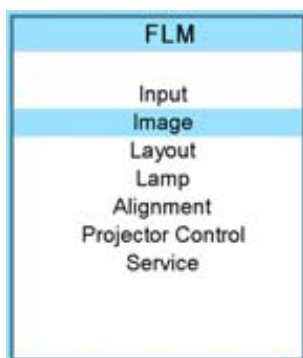

Image 9-32



Image 9-33

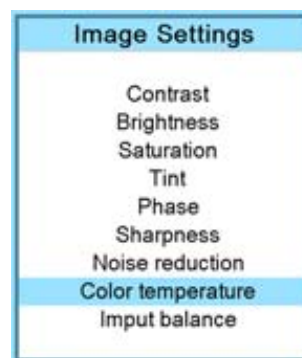

Image 9-34

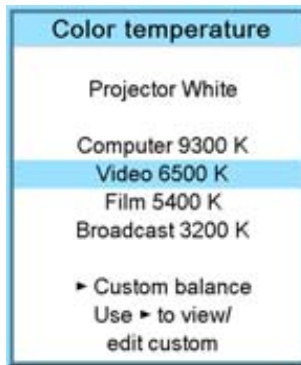

Image 9-35

### 9.3.8.2 Set a custom color temperature

#### How to enter a custom value?

1. Press **MENU** to activate the menus.
2. Use the **▲** or **▼** key to select *Image* and press **ENTER**.
3. Use the **▲** or **▼** key to select *Image settings* and press **ENTER**.
4. Use the **▲** or **▼** key to select *Color temperature* and press **ENTER**.
5. Use the **▲** or **▼** key to select *Custom balance* and press **▶**.

The Gain adjustment bar scales are displayed.

6. Adjust gain red with **◀** or **▶** key and gain blue with **▲** or **▼** key. Adjust gain blue in the same way as gain red.
7. When gain adjustment is finished press **ENTER**.

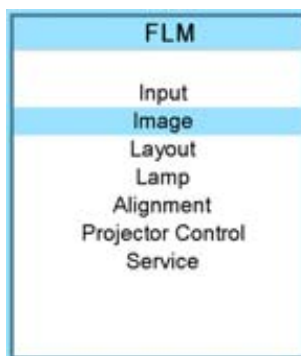

Image 9-36



Image 9-37

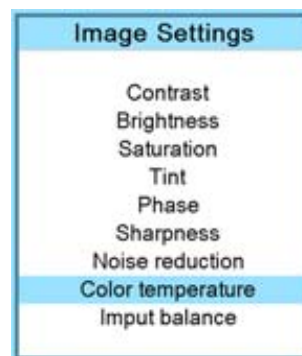

Image 9-38

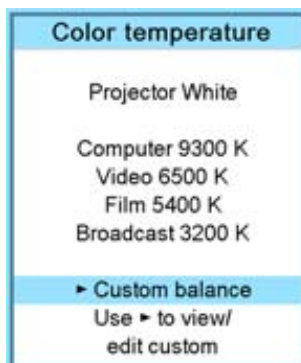

Image 9-39



Image 9-40

### 9.3.9 Input balance

#### Overview

- Introduction to Input Balance
- Adjusting the input balance

#### 9.3.9.1 Introduction to Input Balance

##### Introduction: Unbalanced color signals

When transporting signals, there is always a risk of deterioration of the information contained in the signals.

In case of information contained in the amplitude of the signals which is the case of data color signals (R, G, B), image 9-41, we are quite sure that the amplitude of these color signals is subject to alterations.

An example of alteration may be a DC component added to the signal, in the form of a DC offset repositioning the black level, since this **black level** (“**brightness**”) will become crucial later on (clamping circuit) it will result in “black not being black”.

Another value that is subject to alteration is the amplitude of the signal, resulting in an altered “Gain” of the signal (“**white level**” or **contrast**).

The alterations of the three color signals will happen independently i.e. the colors will end to be unbalanced, image 9-42

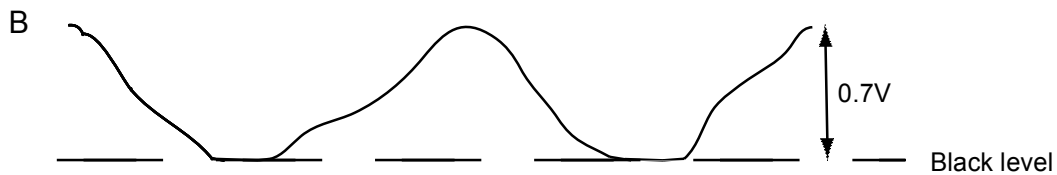

Image 9-41

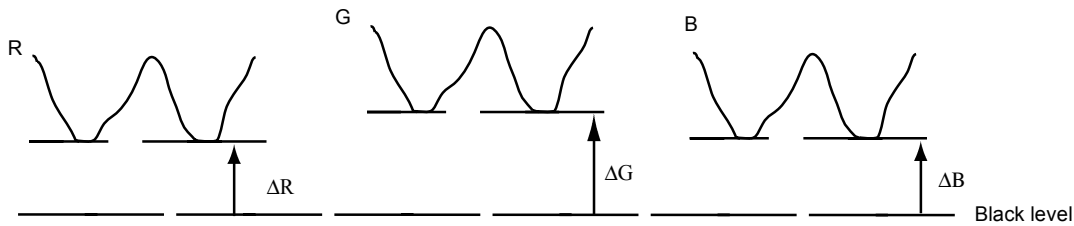

Image 9-42



One can conclude here that a good color tracking can only be met by using three previously (input) balanced color signals

#### Analog Digital Conversion

The analog color signals must pass through an Analog/Digital conversion circuit prior to any digital processing in the PMP.

A typical ADC transforms the analog value into an 8 bit coded digital signal.

The graphic shows that when converting a signal containing a DC offset component the range of the converter is not optimally used.

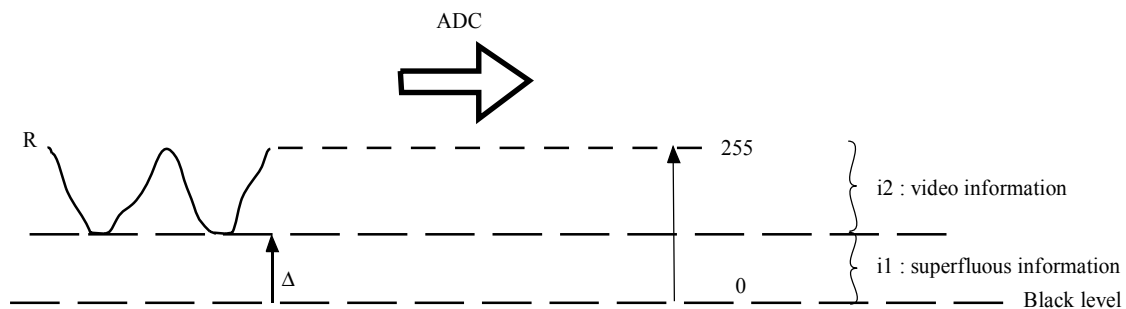

Image 9-43



One can conclude here that a good data conversion can only be met by using three previously (input) balanced color signals

### The objective of input balancing

The objective in input balancing is to “set” the same black level and the same white level for the three colors of a particular input source.



**Black level setting : brightness**

**White level setting : contrast**

The same absolute black and white level for the three colors allows the same reference for Brightness and Contrast control of the picture !

These two references also set the range in which the ADC will work for that particular source (this explains also why each input balance setting is linked to a particular source and thus saved in the image file).

### 9.3.9.2 Adjusting the input balance

#### How can it be done ?

To balance the three color signals of a particular source there are conditions; in fact we must know the black and the white level of the source i.e. :

1. The source in question must be able to generate a white signal, ideally a 100% white (background) full screen pattern
2. The source in question must be able to generate a black signal, ideally a 100% black (background) full screen pattern

A



B

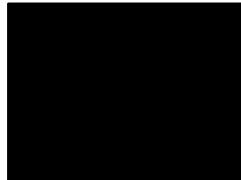

Image 9-44

**White balance :** In the projector, we will set the contrast for each color until we get a 100% light output picture when projecting a 100% white image (image A)

**Black balance :** In the projector, we will set the brightness for each color until we get a 0% light output picture when projecting a 100% black image (image B).



The changeover from min to max is indicated by the apparition of bright spots also called “digital noise”



An alternative to a full screen White/black pattern is the standard gray scale pattern, the white bar will be used for white balance and the black bar for black balance.

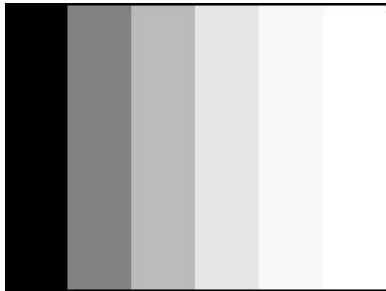

Image 9-45

### Black balance

1. Press **MENU** to activate the menus.
2. Use the **▲** or **▼** key to select *Image* and press **ENTER**.
3. Use the **▲** or **▼** key to select *Image settings* and press **ENTER**.
4. Use the **▲** or **▼** key to select *Input balance* and press **ENTER**.
5. Do you want to use an internally generated test pattern ?  
If yes, Use the **▲** or **▼** key to select *Test pattern* and press **ENTER** to toggle between [on] and [off]  
If no, Adjust on the selected source.
6. Use the **▲** or **▼** key to select *Black balance* and press **ENTER**.  
Depending whether a test pattern is selected or not, the adjustment image is displayed.
7. Toggle with **▲** or **▼** key to select *Black balance red*.

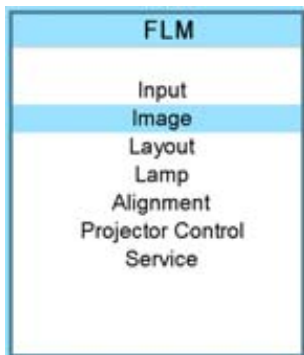

Image 9-46



Image 9-47

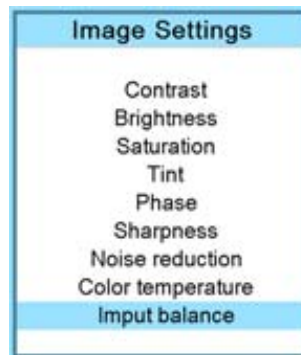

Image 9-48

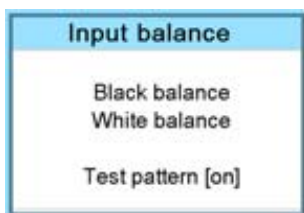

Image 9-49

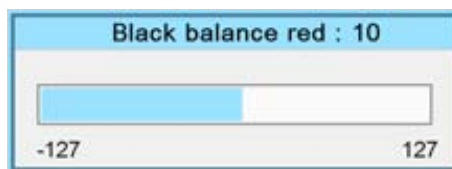

Image 9-50

8. Adjust the red black level on a minimal value
9. Toggle with **▲** or **▼** key to *Black balance blue* and adjust the blue black level on a minimal value.  
**Note:** This minimal value is not necessary, provided that the 2 other colors are not influencing too much the color to be adjusted, in fact the aim is to minimize the effect of the two other colors since there is a risk of reaching too soon the 50% transition due to the contribution of these two other colors signals.
10. Toggle with **▲** or **▼** key to *Black balance green* and adjust the Green black level until bright spots appear on the screen.
11. Toggle with **▲** or **▼** key to *Black balance blue* adjust the Blue black level until bright spots appear on the screen.
12. Toggle with **▲** or **▼** key to *Black balance red* adjust the Red black level until bright spots appear on the screen.



The projected image should now be noisy full black



If one uses a gray scale pattern, the bright spots should appear in the black bar.

### Performing White input balance

1. Connect the source you want to project.
2. Press **MENU** to activate the menus.
3. Use the **▲** or **▼** key to select *Image* and press **ENTER**.
4. Use the **▲** or **▼** key to select *Image settings* and press **ENTER**.
5. Use the **▲** or **▼** key to select *Input balance* and press **ENTER**.
6. Do you want to use an internally generated test pattern?  
If yes, Use the **▲** or **▼** key to select *Test pattern* and press **ENTER** to toggle between [on] and [off]  
If no, select a white pattern (or gray scale as alternative).
7. Use the **▲** or **▼** key to select *White balance* and press **ENTER**.  
The white balance bar scale for a typical color is displayed.
8. Toggle with the **▲** or **▼** key to select *White balance red*.

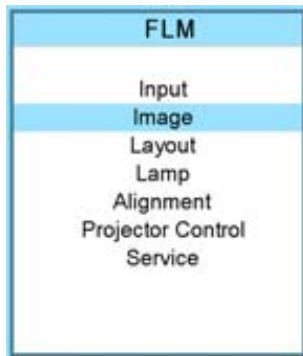

Image 9-51



Image 9-52

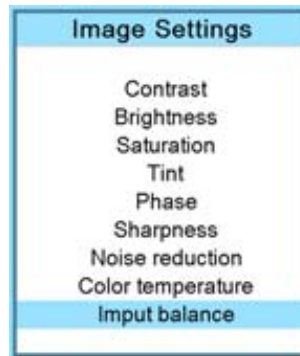

Image 9-53

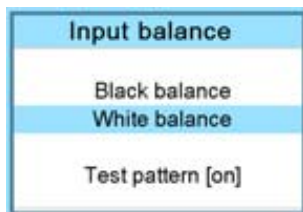

Image 9-54

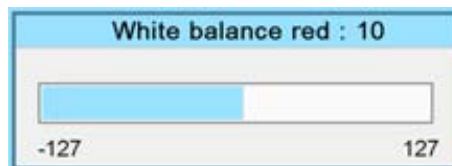

Image 9-55

9. Adjust the red white level (gain) on a minimal value
10. Toggle with **▲** or **▼** key to *White balance blue* and adjust the blue white level (gain) on a minimal value.  
**Note:** *This minimal value is not necessary, provided that the 2 other colors are not influencing too much the color to be adjusted, in fact the aim is to minimize the effect of the two other colors since there is a risk of reaching too soon the transition (bright spots) due to the contribution of these two other colors signals.*
11. Toggle with **▲** or **▼** key to *White balance green* and adjust the Green white level (gain) until bright spots appear on the screen.
12. Toggle with **▲** or **▼** key to *White balance blue* adjust the Blue white level (gain) until bright spots appear on the screen.
13. Toggle with **▲** or **▼** key to *White balance red* adjust the Red white level (gain) until bright spots appear on the screen.

The projected image should now be noisy neutral gray.

## 9.4 Aspect ratio



### Aspect ratio

Relation between the horizontal & vertical dimension in which the window will be displayed, e.g. 4 by 3 or 16 by 9. Can also be expressed as a decimal number, such as 1.77. The larger the ratio or decimal, the wider are less square the image.

### What can be done?

The aspect ratio setting forces the projector to project an image using a defined aspect ratio.

| Aspect ratio | Description                                       |
|--------------|---|
| 4:3          | Standard television format                        |
| 16:9         | Wide screen television format / anamorphic format |
| 5:4          | Workstation format                                |
| 2.35         | Film format                                       |
| 1.88         |   |
| 1.78         | Wide screen television format / anamorphic format |
| Custom       | Any custom format can be set up                   |

Some example images:

4/3 signal



16/9 RGB signal



Image 9-56  
Example images aspect ratio

### How to select an Aspect ratio?

1. Press **MENU** to activate the menus.
2. Use the **▲** or **▼** key to select *Image* and press **ENTER**.
3. Use the **▲** or **▼** key to select *Aspect ratio* and press **ENTER**.  
The aspect ratio menu will be displayed.
4. Use the **▲** or **▼** key to select the desired aspect ratio and press **ENTER**.

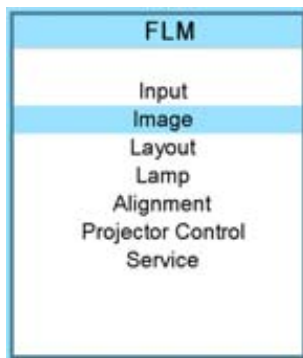

Image 9-57



Image 9-58

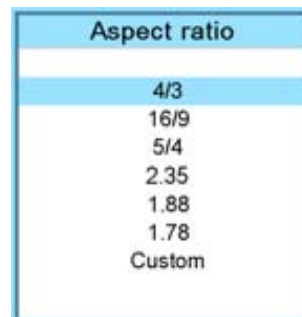

Image 9-59

### How to set up a custom aspect ratio?

1. Select first *Custom* and press **ENTER** to activate.  
The *Custom aspect ratio* dialog box opens.
2. Use the **▲** or **▼** key to adjust the vertical size of the image.

Use the ► or ◀ key to adjust the horizontal size of the image.  
When the desired aspect ratio is obtained, press **EXIT**.

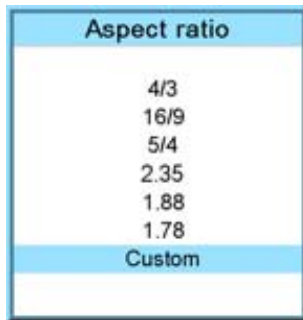

Image 9-60

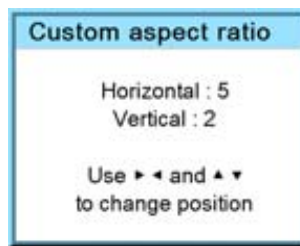

Image 9-61

## 9.5 Timings

### 9.5.1 Source timings

#### Adjustable items

- Horizontal start in pixels : number of pixels between the beginning of the input signal and the start of the video information in the signal.
- Width = Active horizontal pixels : determine the width of the window on the screen. This value is normally given in the source specifications. If not, adjust until full image is displayed (no missing pixels).
- Vertical start in lines : number of lines between the start of the input signal and start of the image on the screen.
- Height = Active vertical lines : number of horizontal lines determining the height of the projected image. this value is normally given in the specification of the source. If not, adjust until full image height is displayed (no missing lines).
- Total pixels: Total horizontal pixels in the source. If the value is wrong, sampling mistakes (small vertical bars in the projected image) will be seen in the image.
- Total lines: Total vertical lines in the source.

#### How to start up?

1. Press **MENU** to activate the menus.
2. Use the ▲ or ▼ key to select *Image* and press **ENTER**.
3. Use the ▲ or ▼ key to select *Timings* and press **ENTER**.

The timings menu will be displayed.

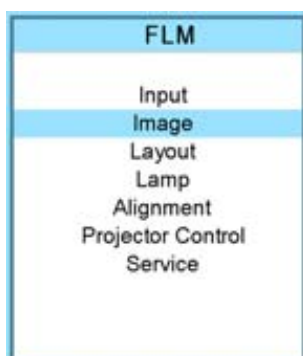

Image 9-62

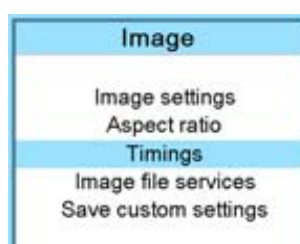

Image 9-63

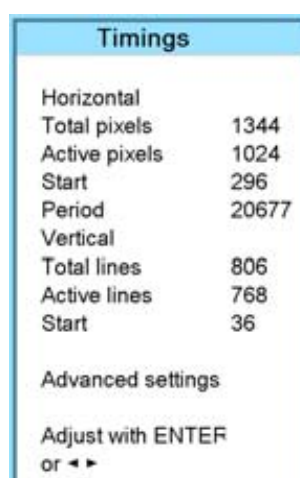

Image 9-64

4. To change a setting, use the ▲ or ▼ key to select and press **ENTER**.

## 9. Image menu

The corresponding adjustment box is displayed. E.g. Horizontal total pixels.

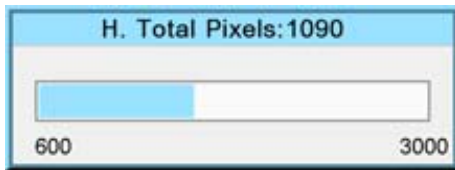

Image 9-65

5. Use the ▲ or ▼ key (or ◀ or ▶ key) to change the value.
6. Press **ENTER** to activate the new value.
7. If necessary to change other settings, repeat from step 4.

### 9.5.2 Advanced settings

#### About the advanced settings

- Clamp delay            The time between the leading edge of the clamp pulse and the locked edge of the sync pulse. Can be any value between 0 and 255.
- Clamp width            The width of the clamp pulse can be any value between 0 and 255.

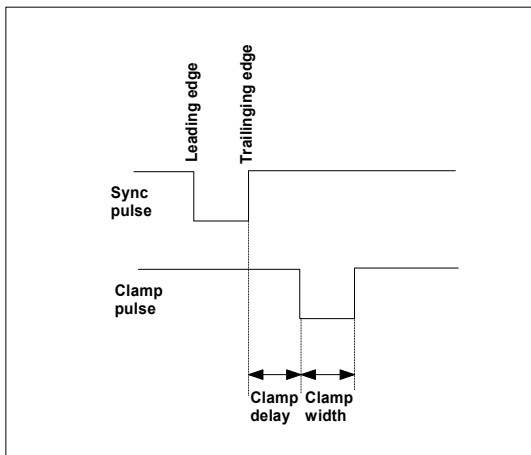

Image 9-66

- Field polarity            The field polarity function is used for interlaced images. Both rasters of the image could be shifted in a wrong way (double lines are visible in the image). This can be corrected by forcing the field polarity to [neg] or [pos].

#### How to change the clamp delay - clamp width?

1. Press **MENU** to activate the menus.
2. Use the ▲ or ▼ key to select *Image* and press **ENTER**.
3. Use the ▲ or ▼ key to select *Timings* and press **ENTER**.
4. Use the ▲ or ▼ key to select *Advanced settings* and press **ENTER**.  
The Advanced settings menu is displayed.
5. Use the ▲ or ▼ key to select *Clamp delay* or *Clamp width* and press **ENTER**.  
A progress bar appears.
6. Use the ▲ or ▼ key to change the setting.

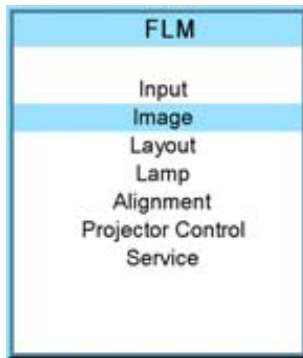

Image 9-67

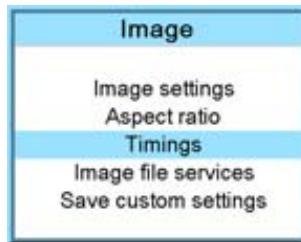

Image 9-68

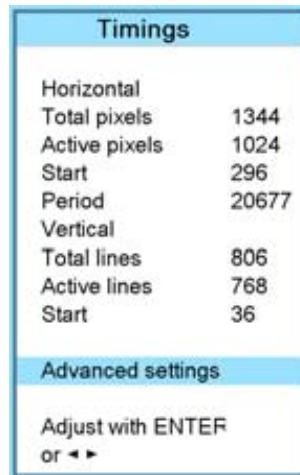

Image 9-69

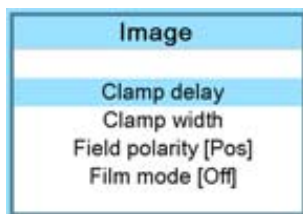

Image 9-70

### How to change the field polarity?

1. Press **MENU** to activate the menus.
2. Use the ▲ or ▼ key to select *Image* and press **ENTER**.
3. Use the ▲ or ▼ key to select *Advanced settings* and press **ENTER**.

The Advanced settings menu is displayed.

4. Use the ▲ or ▼ key to select *Field polarity* and press **ENTER** to toggle between [neg] or [pos].

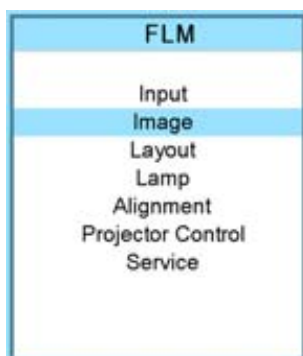

Image 9-71

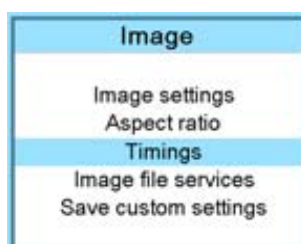

Image 9-72

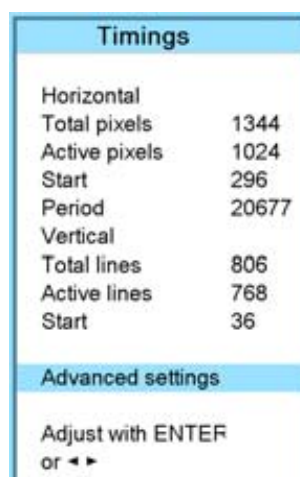

Image 9-73

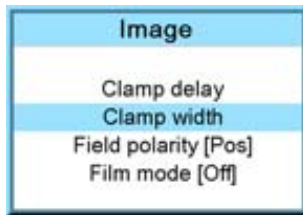

Image 9-74

### 9.5.3 Advanced settings, film mode detection

#### About film mode detection

This mode detects whether film or video is displayed.

When enabled, the hardware looks for tell-tale signs of 3:2 or 2:2 pull-down sequences. These are the result of converting cinema material recorded at 24 frames-per-second to the television frequencies of 60 or 50 interlaced fields per second respectively. When FILM conversion is detected, the original 24 frames-per-second are restored. This avoids deinterlacing artefacts, and results in a perfect artefact-free display. Note that in some cases (video clips, scrolling newstickers,...) FILM and VIDEO material are mixed on one screen. This may confuse the detector and cause it to go into FILM restoration mode. This will cause "jaggies" or motion artefacts. In such cases, disabling FILM mode processing is the best cure.



**Film mode detection is only for interlaced sources.**

---



#### 3:2 pull-down

Method used to map the 24 fps of film onto the 30 fps (60 fields) or 25 fps (50 fields), so that one film frame occupies three video fields, the next two, etc. It means the two fields of every other video frame come from different film frames making operations such as rotoscoping impossible, and requiring care in editing. Some sophisticated equipment can unravel the 3:2 sequence to allow frame-by-frame treatment and subsequently re-compose 3:2. The 3:2 sequence repeats every five video frames and four film frames, the latter identified as A-D. Only film frame A is fully on a video frame and so exists at one time code only, making it the editable point of the video sequence.

---



#### 2:2 pull-down

The process of transferring 24-frames/sec film format into video by repeating each frame (used for PAL DVD's) as two video fields. ( AD )

---



#### Artefacts

Undesirable elements or defects in a video picture. These may occur naturally in the video process and must be eliminated in order to achieve a high-quality picture. Most common in analog are cross color and cross luminance. Most common in digital are macroblocks, which resemble pixelation of the video image.

---

#### How to set up

1. Press **MENU** to activate the menus.
2. Use the **▲** or **▼** key to select *Image* and press **ENTER**.
3. Use the **▲** or **▼** key to select *Advanced settings* and press **ENTER**.  
The Advanced settings menu is displayed.
4. Use the **▲** or **▼** key to select *Film mode* and press **ENTER** to toggle between [auto] or [off].

- Auto Detects for film and it starts to avoid deinterlacing artefacts, and it results in a perfect artefact-free display.
- Off no detection for film mode.

When film with a banner is projected at the same time, and film mode is auto, the banner will shown possible artefacts as the software will detect a film.

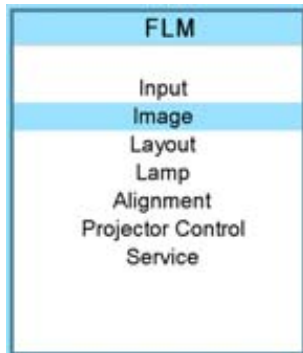

Image 9-75



Image 9-76

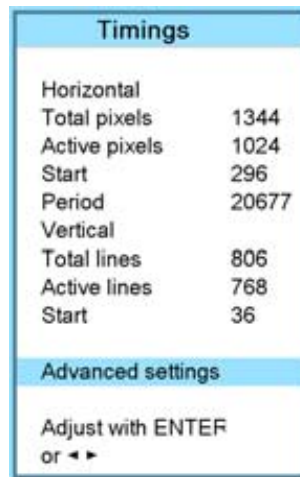

Image 9-77

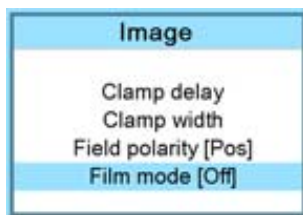

Image 9-78

## 9.6 Image files services

### Overview

- Files and file manipulations
- Manual Load file
- Delete file
- Delete all custom files
- Rename a file
- Copy a file
- File options

### 9.6.1 Files and file manipulations

#### Connecting a new source.

Before using a new source, a correct file has to be installed. The projector's memory contains a list of files corresponding to the most used sources. When the new source corresponds with one of these files, the file can be loaded and saved for future use. When there is a little difference, the file can also be loaded and then edited until the source specs are reached.

VESA standards and video standards are pre-programmed.

### Possible file Manipulations

The following file manipulations are possible :

- Load : installation of a file for a new source.
- Rename : renaming a file.
- Delete : deleting a file (only custom files)
- Delete all : delete all custom files
- Options : way of loading a file when a source is selected.

A loaded file can be edited via the Timings menu. Once a file is edited, it will be saved with the same name as the original file, followed by a sequence number between rounded brackets.

### 9.6.2 Manual Load file

#### How to load?

1. Press **MENU** to activate the menus.
2. Use the **▲** or **▼** key to select *Image* and press **ENTER**.
3. Use the **▲** or **▼** key to select *File services* and press **ENTER**.

The File service menu is displayed.

4. Use the **▲** or **▼** key to select *Manual load* and press **ENTER**.

The manual load window opens.

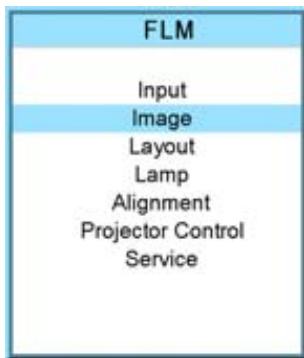

Image 9-79



Image 9-80

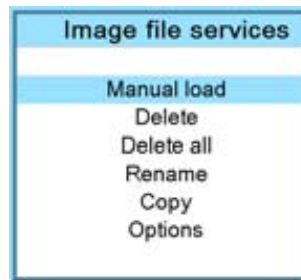

Image 9-81

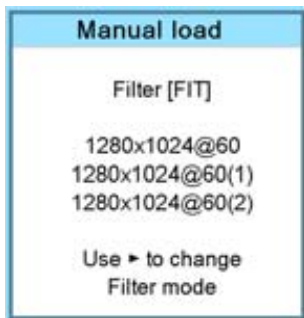

Image 9-82

Depending on the filter setup, the following is displayed:

- Fit: only fitting files for the selected source will be in the list
- All: all files in the system will be in the list.

5. Do you want to see only the fitting file in the manual load menu?  
If yes, Select *Filter* and use **►** till [FIT] is on the menu.  
If no, Select *Filter* and use **►** till [ALL] is on the menu.

6. Use the **▲** or **▼** key to select the appropriate file. While scrolling over the files, a preview is shown on the screen.

7. Press **ENTER** to select.

The selected file is loaded.

#### The image is not perfect?

If the displayed image is not correct after selecting the best fitting file, go to the *Timings* menu and change the file settings.



### 9.6.3 Delete file

#### How to delete?

1. Press **MENU** to activate the menus.
2. Use the **▲** or **▼** key to select *Image* and press **ENTER**.
3. Use the **▲** or **▼** key to select *File services* and press **ENTER**.  
The File service menu is displayed.
4. Use the **▲** or **▼** key to select *Delete* and press **ENTER**.  
The delete window opens.
5. Use the **▲** or **▼** key to select the file which must be deleted.  
**Note:** *Only custom files can be deleted.*
6. Press **ENTER** to delete the selected file.

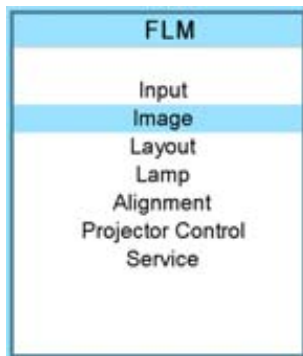

Image 9-83



Image 9-84

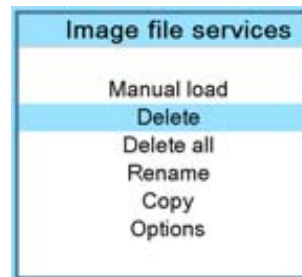

Image 9-85

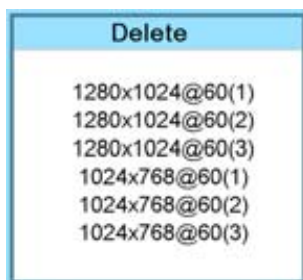

Image 9-86



**No recovery possible !**

### 9.6.4 Delete all custom files

#### How to delete?

1. Press **MENU** to activate the menus.
2. Use the **▲** or **▼** key to select *Image* and press **ENTER**.
3. Use the **▲** or **▼** key to select *File services* and press **ENTER**.  
The File service menu is displayed.
4. Use the **▲** or **▼** key to select *Delete all* and press **ENTER**.  
A delete all confirmation window opens.
5. Use the **▲** or **▼** key to select *Yes* if you are sure to delete all custom files and press **ENTER** to activate the selection.

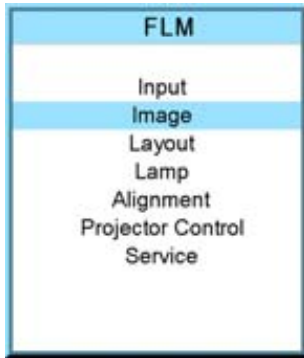

Image 9-87



Image 9-88



Image 9-89

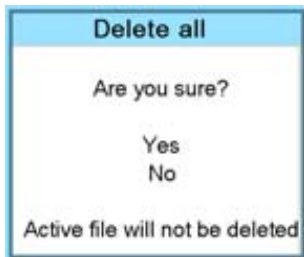

Image 9-90

Or,

if you are not sure to delete all custom files, select *No* and press **ENTER** to activate the selection.

### 9.6.5 Rename a file

#### How to rename?

1. Press **MENU** to activate the menus.
2. Use the ▲ or ▼ key to select *Image* and press **ENTER**.
3. Use the ▲ or ▼ key to select *File services* and press **ENTER**.  
The File service menu is displayed.
4. Use the ▲ or ▼ key to select *Rename* and press **ENTER**.  
The rename window opens.
5. Use the ▲ or ▼ key to select the file which must be renamed.  
**Note:** *Only custom files can be renamed.*
6. Press **ENTER** to select.  
The rename window opens. The first character is selected.
7. Use the ▲ or ▼ key to change the selected character.  
Use the ◀ or ▶ key to selected another character.  
**Note:** *Digits can be entered with the digit keys on the remote control or on the local keypad. When a digit is entered in that way, the next character will be selected automatically.*
8. Press **ENTER** to finalize the rename action.

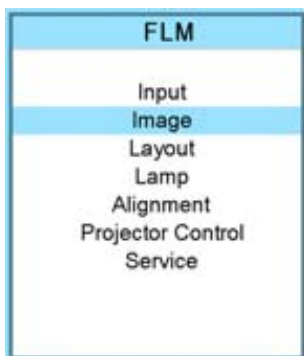

Image 9-91



Image 9-92

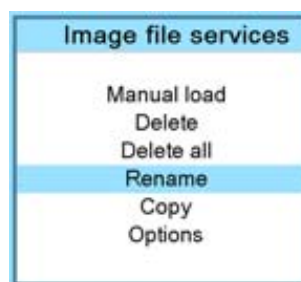

Image 9-93

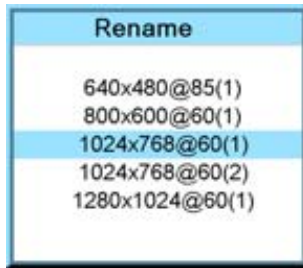

Image 9-94

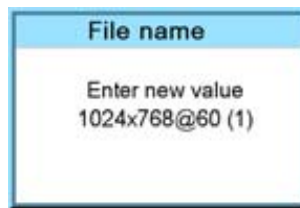

Image 9-95

### 9.6.6 Copy a file

#### How to copy?

1. Press **MENU** to activate the menus.
2. Use the **▲** or **▼** key to select *Image* and press **ENTER**.
3. Use the **▲** or **▼** key to select *File services* and press **ENTER**.  
The File service menu is displayed.
4. Use the **▲** or **▼** key to select *Copy* and press **ENTER**.  
The copy window opens.
5. Use the **▲** or **▼** key to select the file which must be copied.
6. Press **ENTER** to select.

The copy window opens. The first character is selected.

7. Use the **▲** or **▼** key to change the selected character.  
Use the **◀** or **▶** key to selected another character.

**Note:** *Digits can be entered with the digit keys on the remote control or on the local keypad. When a digit is entered in that way, the next character will be selected automatically.*

8. Press **ENTER** to finalize the copy action.

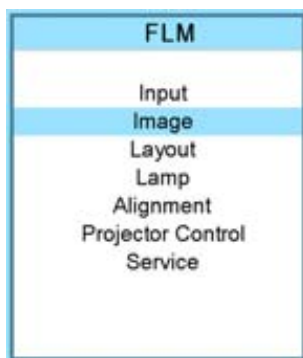

Image 9-96



Image 9-97

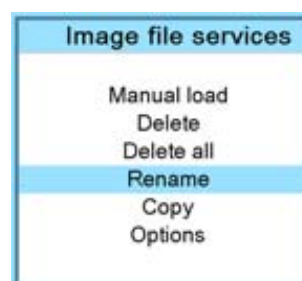

Image 9-98

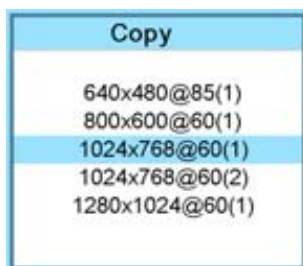

Image 9-99

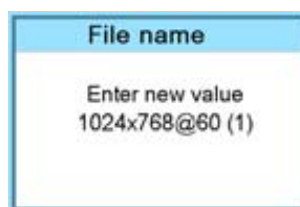

Image 9-100

### 9.6.7 File options

#### How to set the options?

1. Press **MENU** to activate the menus.

## 9. Image menu

---

2. Use the ▲ or ▼ key to select *Image* and press **ENTER**.
3. Use the ▲ or ▼ key to select *Image services* and press **ENTER**.  
The Image service menu is displayed.
4. Use the ▲ or ▼ key to select *Options* and press **ENTER**.

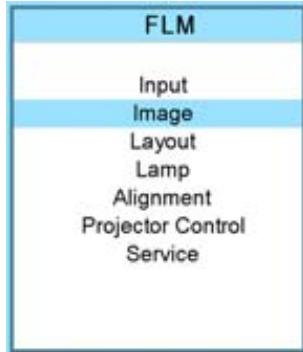

Image 9-101



Image 9-102



Image 9-103

The options window opens.

5. Use the ▲ or ▼ key to select *Load file* and press **ENTER** to toggle between [Automatic], [Manual] and [Custom only].
  - [Automatic]: correct file will be loaded automatically.
  - [Manual]: correct file has to be loaded manually.
  - [Custom only]: correct file will be loaded automatically out of the available custom files.

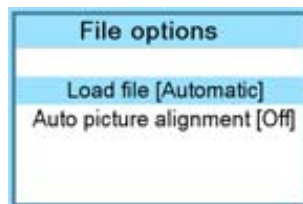

Image 9-104

6. Use the ▲ or ▼ key to select *Auto picture alignment* and press **ENTER** to toggle between [Off], [Always] and [File load].

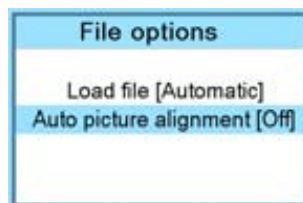

Image 9-105

- [Off]: no auto picture alignment activated.
- [Always]: always auto picture alignment activated. When sync disappears and comes back, an auto picture alignment is executed.
- [Load file]: auto picture alignment executed each time a new file is loaded.

## 9.7 Save custom settings

---

### What is done?

The current custom settings can be saved to the internal backup device in the same way as it would be done when the projector was switched to standby.

### How to save

1. Press **MENU** to activate the menus.
2. Use the ▲ or ▼ key to select *Image* and press **ENTER**.
3. Use the ▲ or ▼ key to select *Save custom settings* and press **ENTER**.

The custom settings are written to the internal backup device. A message menu "Save data ..." is displayed during the save operation.

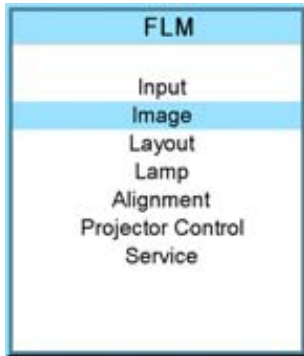

Image 9-106

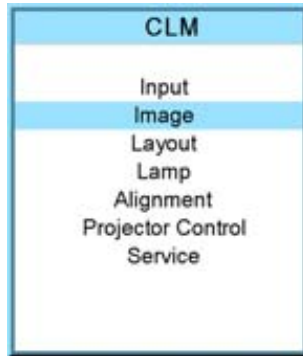

Image 9-107



Image 9-108



# 10. LAYOUT MENU

## Overview

- Overview flow
- Main window
- PIP window
- Layout file services
- Zoom - Focus

## 10.1 Overview flow

### Overview

| Level 1 | Level 2              | Level 3   | Level 4   |
|---------|----------------------|---|---|
| Layout  |                      |   |   |
|         | Main window          | Source<br>Size<br>Position                        |   |
|         | PIP window           | PIP window [ON/OFF]<br>Source<br>Size<br>Position |   |
|         | Layout file services | Load  | Main full screen<br>PIP top right<br>Split top bottom |
|         |                      | Rename<br>Delete<br>Copy / Save as                |   |
|         | Zoom/Focus           | Same for each layout                              | yes<br>no   |

## 10.2 Main window

### Overview

- Source selection
- Size adjustment
- Position adjustment

### When active layout is read only

When the active layout is a read only layout, the projector will ask to create a new layout.

Use the ▲ or ▼ key to select *Yes* or *No* and press **ENTER**.

If *Yes* is selected an *Enter layout name* window opens.

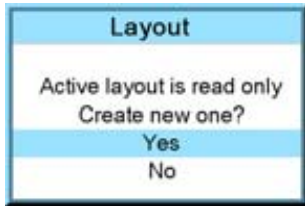

Image 10-1

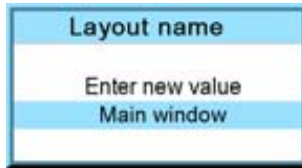

Image 10-2

The first character is highlighted. Use the ▲ or ▼ key to select the desired character and press ◀ or ▶ key to select the next character in the name.

Press **EXIT** to return. The new file is generated.

### 10.2.1 Source selection

#### What can be done ?

The source of the main window can be selected via the *Main window* menu.

#### How to select a source

1. Press **MENU** to activate the menus.
2. Use the ▲ or ▼ key to select *Layout* and press **ENTER**.
3. Use the ▲ or ▼ key to select *Main Window* and press **ENTER**.  
The main window opens.
4. Use the ▲ or ▼ key to select *Source* and press **ENTER**.  
The source selection window opens.
5. Use the ▲ or ▼ key to select the desired source and press **ENTER** to activate.

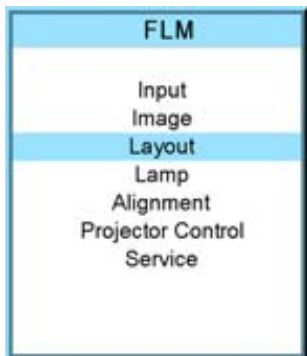

Image 10-3

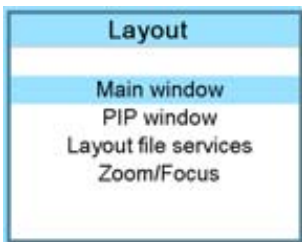

Image 10-4

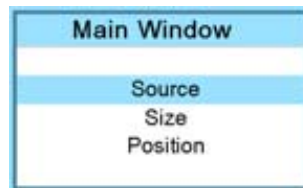

Image 10-5

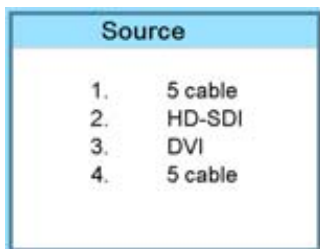

Image 10-6

### 10.2.2 Size adjustment

#### What can be done?

The size of the main window can be adjusted until the desired window dimensions are reached.



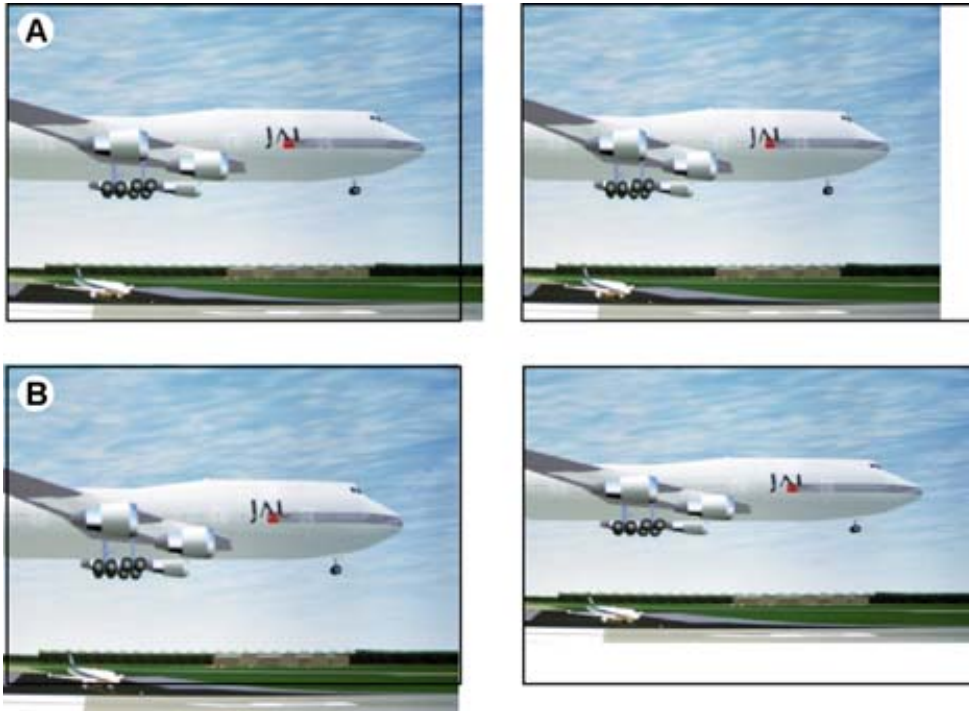

Image 10-7  
Size adjustment main window

- A width adjustment  
B height adjustment

The size can be changed with respect to the original aspect ratio.

### How to adjust with respect to the original aspect ratio?

1. Press **MENU** to activate the menus.
2. Use the **▲** or **▼** key to select *Layout* and press **ENTER**.
3. Use the **▲** or **▼** key to select *Main Window* and press **ENTER**.

The main window opens.

4. Use the **▲** or **▼** key to select *Size* and press **ENTER**.

The size adjustment window opens.

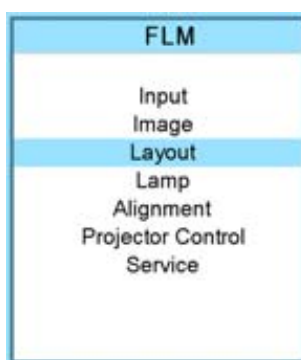

Image 10-8

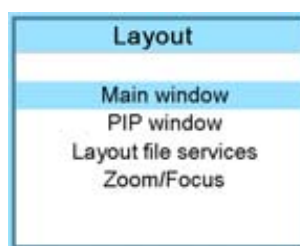

Image 10-9

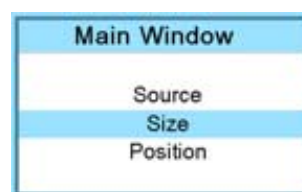

Image 10-10

5. Toggle with **ENTER** till Lock is set to [x].

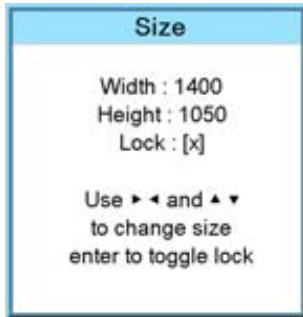

Image 10-11

[ ] = no lock between height and width.

[x] = width and height are locked.

- Use right arrow, left arrow or right arrow, down arrow to adjust the size with respect to the original aspect ratio. When the desired size is reached, press **EXIT**.

A Save window opens.

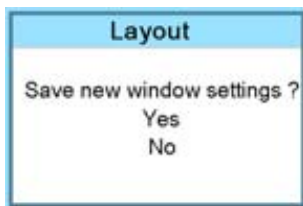

Image 10-12

### How to adjust height and width separately?

- Press **MENU** to activate the menus.
- Use the up arrow or down arrow key to select *Layout* and press **ENTER**.
- Use the up arrow or down arrow key to select *Main Window* and press **ENTER**.  
The main window opens.
- Use the up arrow or down arrow key to select *Size* and press **ENTER**.  
The size adjustment window opens.

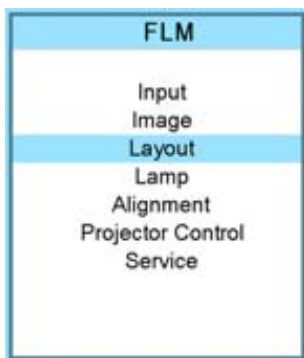

Image 10-13

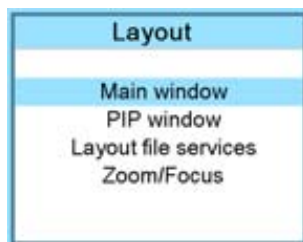

Image 10-14

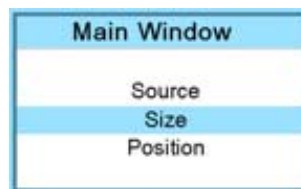

Image 10-15

- Toggle with **ENTER** till Lock is set to [ ].

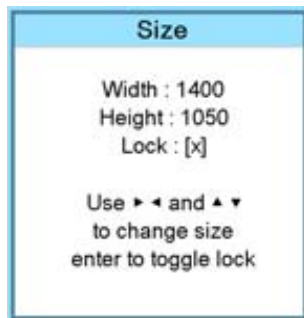

Image 10-16

[ ] = no lock between height and width.

[x] = width and height are locked.

- Use the ▲ or ▼ key to adjust the height.  
Use the ◀ or ▶ key to adjust the width.  
When the desired size is reached, press **EXIT**.

A Save window opens.

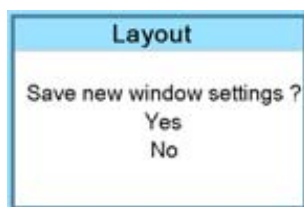

Image 10-17

- Select with the ▲ or ▼ key Yes and press **ENTER**.  
Select with the ▲ or ▼ key No, when no save is desired and press **ENTER**.

### 10.2.3 Position adjustment

#### What can be done?

The main window can be repositioned on the screen. The upper left corner is the reference.

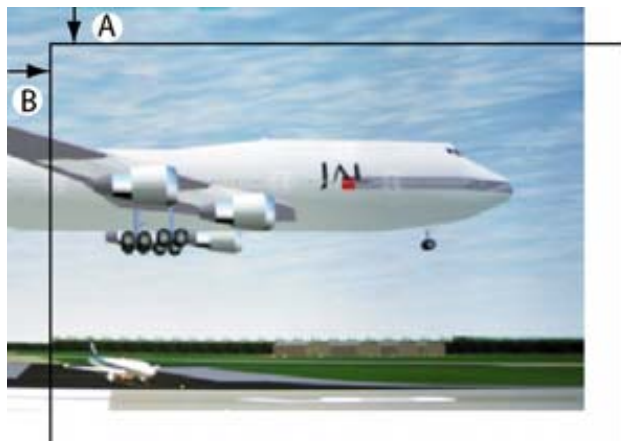

Image 10-18  
Positioning the window

#### How to position?

- Press **MENU** to activate the menus.
- Use the ▲ or ▼ key to select *Layout* and press **ENTER**.
- Use the ▲ or ▼ key to select *Main Window* and press **ENTER**.  
The main window opens.
- Use the ▲ or ▼ key to select *Position* and press **ENTER**.  
The position adjustment window opens.
- Use the ▲ or ▼ key to adjust top start point.

## 10. Layout menu

---

Use the ◀ or ▶ key to adjust left start point.  
When the desired size is reached, press **EXIT**.

A Save window opens.

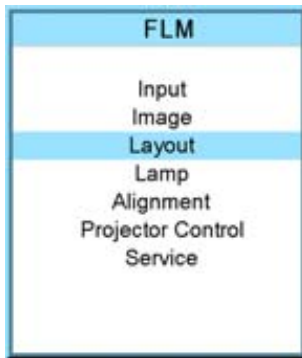

Image 10-19

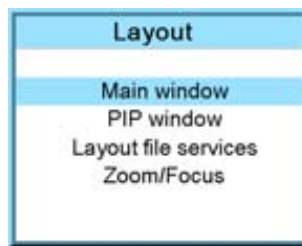

Image 10-20

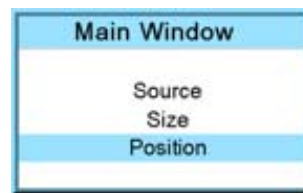

Image 10-21



Image 10-22

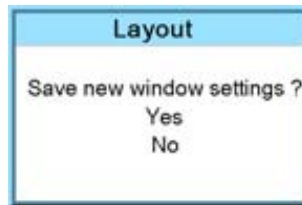

Image 10-23

6. Select with the ▲ or ▼ key **Save** and press **ENTER**.  
Select with the ▲ or ▼ key **Delete**, when no save is desired and press **ENTER**.

## 10.3 PIP window

---

### Overview

- Introduction to PIP
- Picture in Picture activation
- Picture in Picture source selection
- Picture in Picture size of the window
- Picture in Picture, position window

### 10.3.1 Introduction to PIP

---



#### PiP

PiP stands for "Picture in Picture" and allows to display multiple windows containing each of them an image. The windows may be of the video or data type.

---

#### What are the different possibilities within the PiP mode ?

The input section of the projector allows a combinations of different input signals which may be projected in the 2 windows of the PiP screen. The PiP window can be placed anywhere, with any dimensions, on the screen by changing its position and its size.

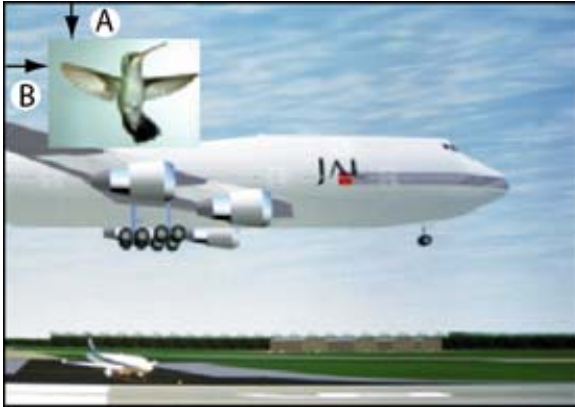

Image 10-24  
Position of PIP

- A Top position  
B Left position

### 10.3.2 Picture in Picture activation

#### How to activate PIP?

1. Press **MENU** to activate the menus.
2. Use the **▲** or **▼** key to select *Layout* and press **ENTER**.
3. Use the **▲** or **▼** key to select *PIP Window* and press **ENTER**.  
The PIP window opens.
4. Use the **▲** or **▼** key to select *On* or *Off* and press **ENTER** to toggle between [On] and [Off].

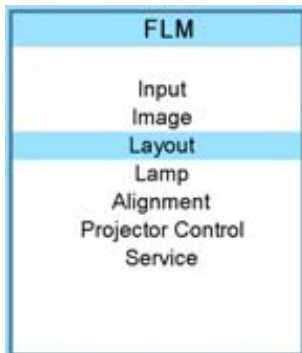

Image 10-25

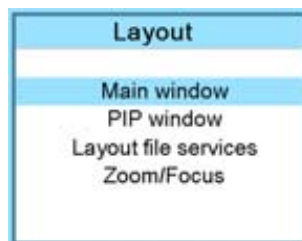

Image 10-26

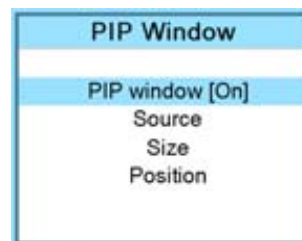

Image 10-27

5. Press **EXIT** to quit the menu.



When PIP is activated (ON state), the PIP window becomes the active window. Switching to the main window is still possible with the window button on the RCU.

### 10.3.3 Picture in Picture source selection

#### What can be done ?

The input source for the picture in picture window can be selected.

#### How to select a source

1. Press **MENU** to activate the menus.
2. Use the **▲** or **▼** key to select *Window* and press **ENTER**.
3. Use the **▲** or **▼** key to select *PIP Window* and press **ENTER**.  
The PIP window dialog opens.
4. Use the **▲** or **▼** key to select *Source* and press **ENTER**.

## 10. Layout menu

The source selection window opens.

- Use the ▲ or ▼ key to select the desired source and press **ENTER** to activate this source.

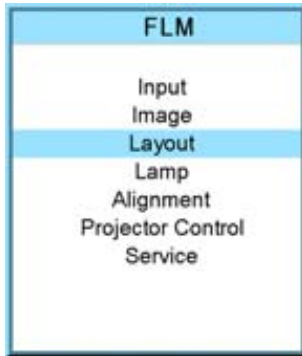

Image 10-28

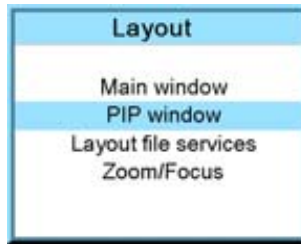

Image 10-29

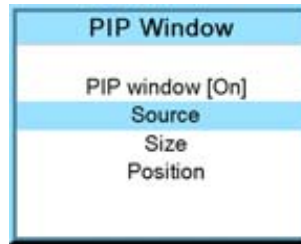

Image 10-30

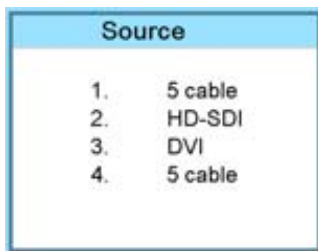

Image 10-31

### 10.3.4 Picture in Picture size of the window

#### What can be done?

The width and height of the picture in picture window can be changed till the desired dimensions are obtained.

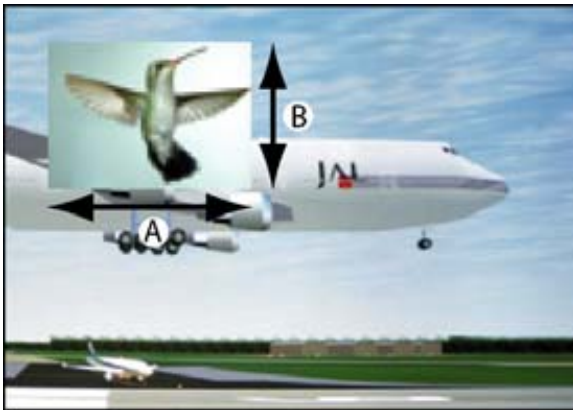

Image 10-32  
Size PIP window

- A Width PIP window
- B Height PIP window

The size of the picture in picture window can be changed with respect to the original aspect ratio of the PIP image.

Remark: when e.g. the PIP window is a 4 by 3 window and the projected image has a 16 by 9 format, then it is possible that image jumps inside the PIP window during a re-scaling. Due to the fact that the re-scale is done on the vertical dimensions of the PIP window and the image inside it will be re-scaled so that the aspect ratio is still correct.



Image 10-33  
Size PIP window remark

### How to change the size with respect to the aspect ratio?

1. Press **MENU** to activate the menu.
2. Use the **▲** or **▼** key to select *Window* and press **ENTER**.
3. Use the **▲** or **▼** key to select *PIP Window* and press **ENTER**.

The main window opens.

4. Use the **▲** or **▼** key to select *Size* and press **ENTER**.

The size adjustment window opens.

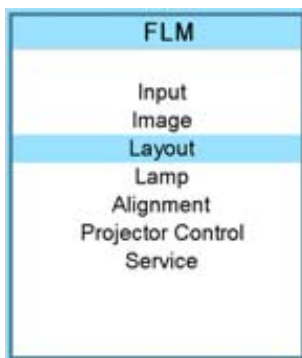

Image 10-34

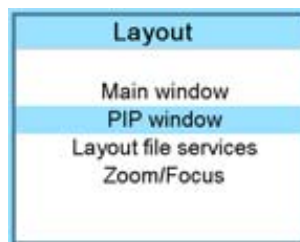

Image 10-35

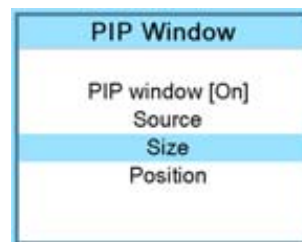

Image 10-36

5. Toggle with **ENTER** till Lock is set to [x].

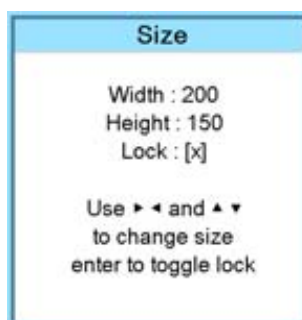

Image 10-37

[ ] = no lock between height and width.

[x] = width and height are locked.

6. Use the **▲** **▼** or **◀** **▶** key to adjust the size with respect to the aspect ratio. When the desired size is reached, press **EXIT**.

## 10. Layout menu

---

A Save window opens.

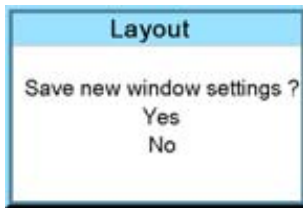

Image 10-38

7. Select with the ▲ or ▼ key Yes and press **ENTER**.  
Select with the ▲ or ▼ key No, when no save is desired and press **ENTER**.

### How to change the height and width separately?

1. Press **MENU** to activate the menus.
2. Use the ▲ or ▼ key to select *Window* and press **ENTER**.
3. Use the ▲ or ▼ key to select *PIP Window* and press **ENTER**.

The main window opens.

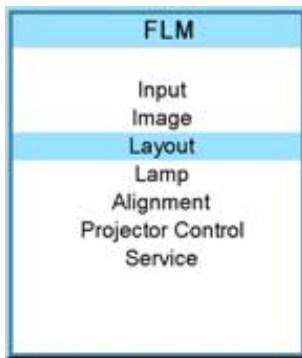

Image 10-39

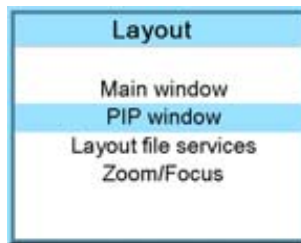

Image 10-40

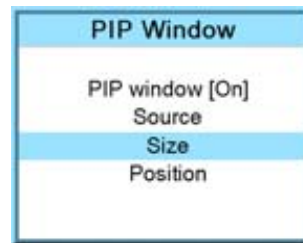

Image 10-41

4. Use the ▲ or ▼ key to select *Size* and press **ENTER**.  
The size adjustment window opens.
5. Toggle with **ENTER** till Lock is set to [ ].

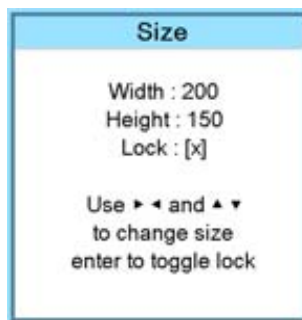

Image 10-42

[ ] = no lock between height and width.

[x] = width and height are locked.

6. Use the ▲ or ▼ key to adjust the height.  
Use the ◀ or ▶ key to adjust the width.  
When the desired size is reached, press **EXIT**.



A Save window opens.

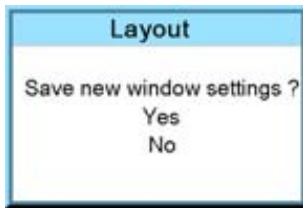

Image 10-43

7. Select with the ▲ or ▼ key Yes and press **ENTER**.  
Select with the ▲ or ▼ key No, when no save is desired and press **ENTER**.

### 10.3.5 Picture in Picture, position window

#### What can be done?

The picture in picture window can be position on any place on the display just by changing its start coordinates. The reference is the upper left corner of the window.

#### How to position?

1. Press **MENU** to activate the menus.
2. Use the ▲ or ▼ key to select *Window* and press **ENTER**.
3. Use the ▲ or ▼ key to select *PIP Window* and press **ENTER**.  
The PIP window opens.
4. Use the ▲ or ▼ key to select *Position* and press **ENTER**.  
The size adjustment window opens.
5. Use the ▲ or ▼ key to adjust Top  
Use the ◀ or ▶ key to adjust Left  
When the desired position is reached, press **EXIT**.

A Save window opens.

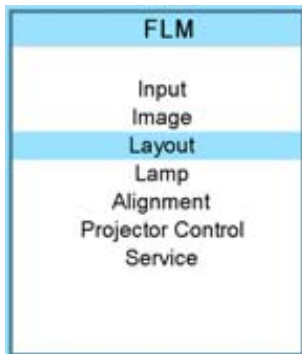

Image 10-44

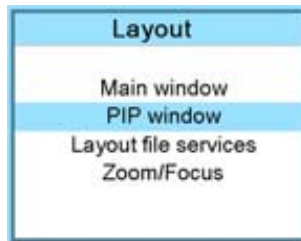

Image 10-45

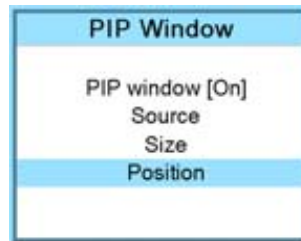

Image 10-46

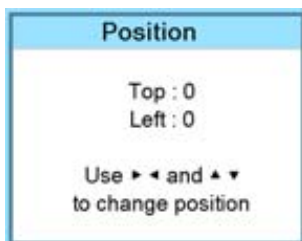

Image 10-47

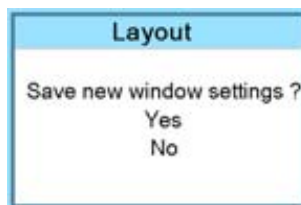

Image 10-48

6. Select with the ▲ or ▼ key Yes and press **ENTER**.  
Select with the ▲ or ▼ key No, when no save is desired and press **ENTER**.

## 10.4 Layout file services

### Overview

- Load layout
- Rename a layout
- Delete a layout
- Copy / Save as a layout

### 10.4.1 Load layout



When loading a layout which required two sources, the *PIP window On/Off* setting will be switched to **ON**.

### How to load?

1. Press **MENU** to activate the menus.
2. Use the **▲** or **▼** key to select *Window* and press **ENTER**.
3. Use the **▲** or **▼** key to select *Layout* and press **ENTER**.  
The layout services window opens.
4. Use the **▲** or **▼** key to select *Load* and press **ENTER**.  
The load layout window opens.

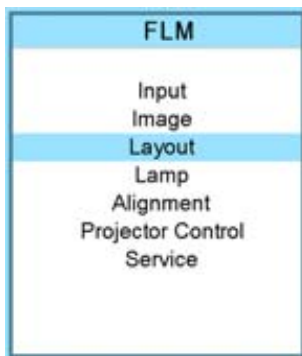

Image 10-49

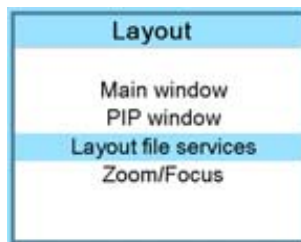

Image 10-50

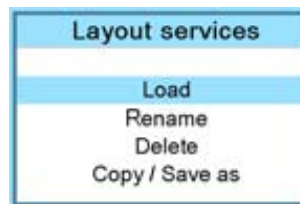

Image 10-51

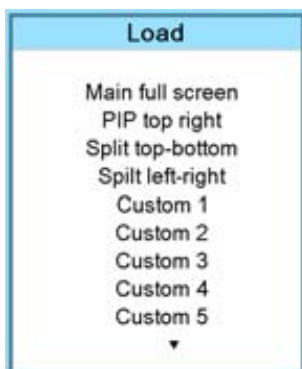

Image 10-52

5. Use the **▲** or **▼** key to select the desired layout and press **ENTER** to select.

The first 4 layouts are default layouts, all others are customer created layouts. The menu shows only the first 10 layouts, but use the **▼** to scroll through the rest of the layouts until the desired layout is found.



**Rigging key + sequence number** opens directly the desired layout.

## 10.4.2 Rename a layout



Only custom created layouts can be renamed.

### How to rename?

1. Press **MENU** to activate the menus.
2. Use the **▲** or **▼** key to select *Window* and press **ENTER**.
3. Use the **▲** or **▼** key to select *Layout* and press **ENTER**.  
The layout services window opens.
4. Use the **▲** or **▼** key to select *Rename* and press **ENTER**.  
The Rename layout location window opens.
5. Use the **▲** or **▼** key to select the layout to rename and press **ENTER**.  
The edit layout name window opens. The first character is selected.
6. Use the **▲** or **▼** key to change the selected character.  
Use the **◀** or **▶** key to selected another character.  
**Note:** *Digits can be entered with the digit keys on the remote control or on the local keypad. When a digit is entered in that way, the next character is selected automatically.*
7. Press **ENTER** to save the new name.

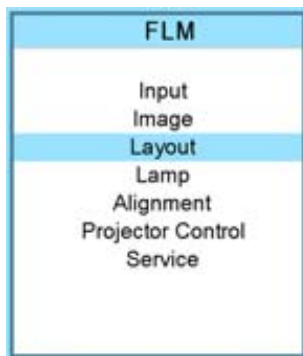

Image 10-53

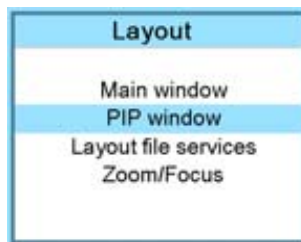

Image 10-54

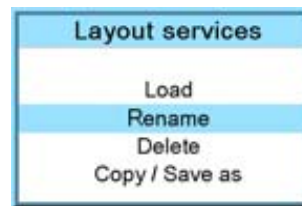

Image 10-55

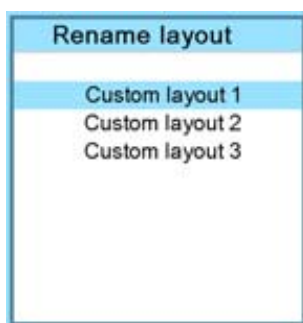

Image 10-56

## 10.4.3 Delete a layout

### What is possible?

Custom created layouts can be removed from the projector memory.

### How to delete?

1. Press **MENU** to activate the menus.
2. Use the **▲** or **▼** key to select *Window* and press **ENTER**.
3. Use the **▲** or **▼** key to select *Layout services* and press **ENTER**.

The layout services window opens.

- Use the ▲ or ▼ key to select *Delete* and press **ENTER**.

The *Delete* window opens.

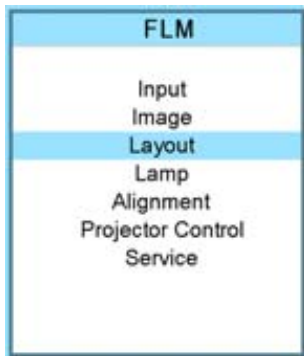

Image 10-57

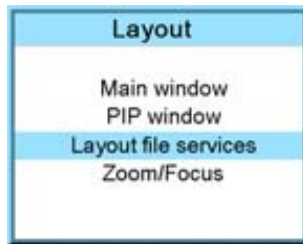

Image 10-58

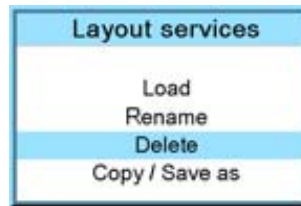

Image 10-59

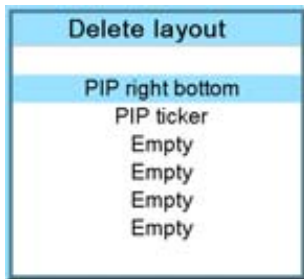

Image 10-60

The first 3 layouts are default layouts and cannot be delete.

- Use the ▲ or ▼ key to select the layout that must be deleted.
- Press **ENTER** to finalize the delete operation.

#### 10.4.4 Copy / Save as a layout

##### What is possible,

An existing layout, system layout or custom created layout, can be copied into a new file.

##### How to copy / save as?

- Press **MENU** to activate the menus.
- Use the ▲ or ▼ key to select *Window* and press **ENTER**.
- Use the ▲ or ▼ key to select *Layout* and press **ENTER**.

The layout services window opens.

- Use the ▲ or ▼ key to select *Copy/Save as* and press **ENTER**.

The Save layout location window opens.

- Use the ▲ or ▼ key to select the layout to copy/save as and press **ENTER**.

The edit layout name window opens. The first character is selected.

- Use the ▲ or ▼ key to change the selected character.  
Use the ◀ or ▶ key to selected another character.

**Note:** *Digits can be entered with the digit keys on the remote control or on the local keypad. When a digit is entered in that way, the next character is selected automatically.*

- Press **ENTER** to copy to the new name.  
The new layout will be added to the list of layouts.

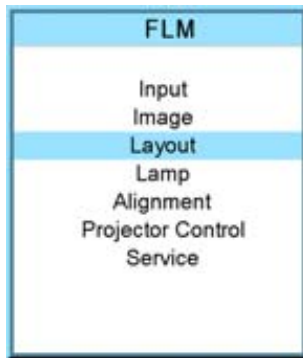

Image 10-61

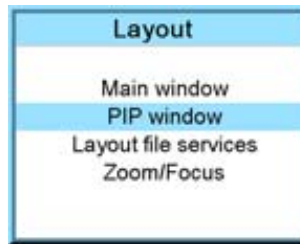

Image 10-62

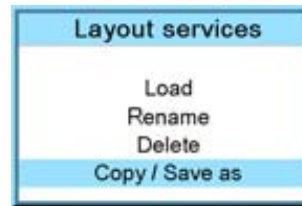

Image 10-63



Image 10-64

## 10.5 Zoom - Focus

### What can be done ?

When changing from one layout to another, the zoom/focus settings can be different for each layout or they can be kept the same for all layouts.

### How to set the zoom - focus setting

1. Press **MENU** to activate the menus.
2. Use the **▲** or **▼** key to select *Window* and press **ENTER**.
3. Use the **▲** or **▼** key to select *Layout* and press **ENTER**  
The layout window opens.
4. Use the **▲** or **▼** key to select *Zoom/Focus as* and press **ENTER**.  
The Zoom/Focus window opens.
5. Press **ENTER** to toggle between *[No]* and *[Yes]*.

[No] = each layout will use its own zoom/focus settings.

[Yes] = each layout will use the same zoom/focus settings. That means that the zoom/focus settings of the previous selected layout will be applied to the next selected layouts.

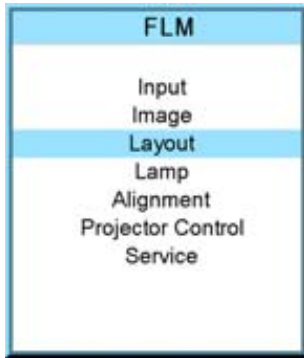

Image 10-65

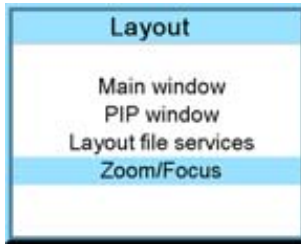

Image 10-66

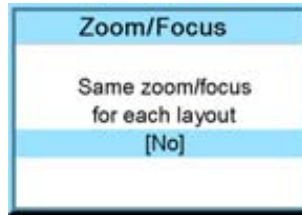

Image 10-67

# 11. LAMP MENU

## Overview

- Overview flow
- Lamp power mode
- Lamp power
- Lamp Identification
- Z-axis adjustment

## 11.1 Overview flow

### Overview

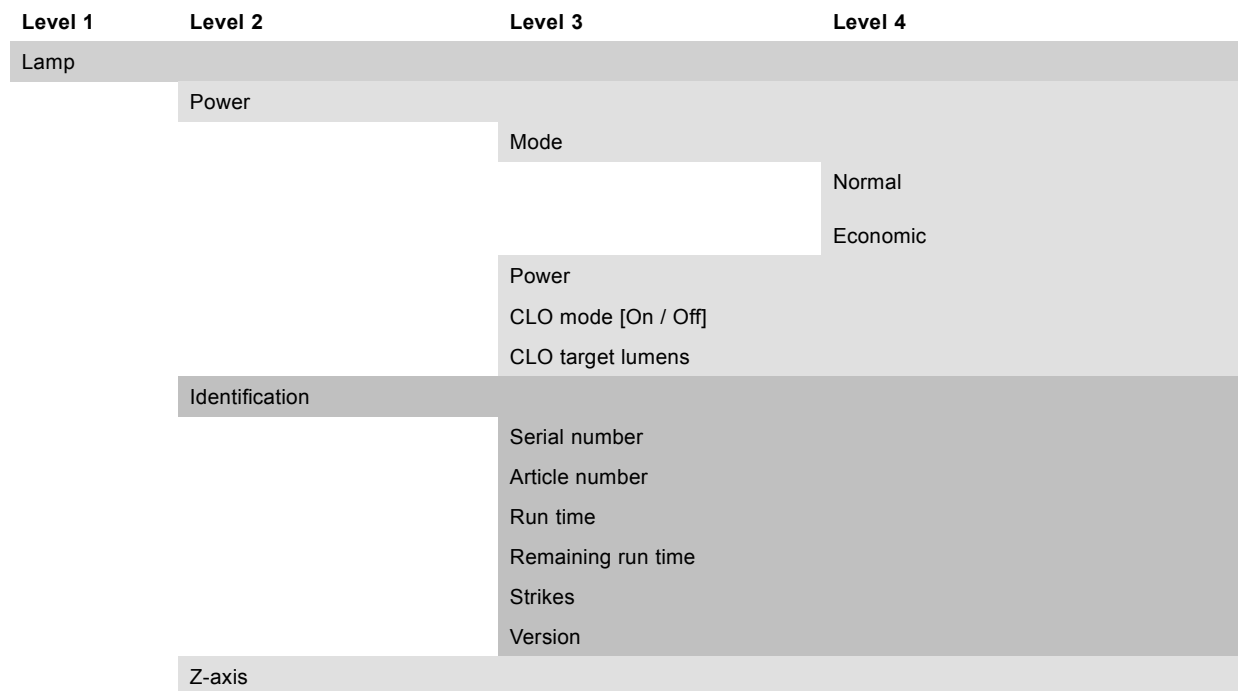

## 11.2 Lamp power mode

### What can be done?

The lamp power mode can be switched between **Normal** and **Economic**. When playing in Economic mode, the lamp life time will increase.

Normal : maximum allowed powers is fed to the lamp. Maximum light output is reached in this way.

Economic : a reduced wattage is fed to the lamp. Reduced light output but a longer life time for the lamp.

### How to switch?

1. Press **MENU** to activate the menus.
2. Use the **▲** or **▼** key to select *Lamp* and press **ENTER**.
3. Use the **▲** or **▼** key to select *Power* and press **ENTER**.
4. Use the **▲** or **▼** key to select *Mode*.
5. Press **ENTER** to toggle between [*Normal*] and [*Economic*].

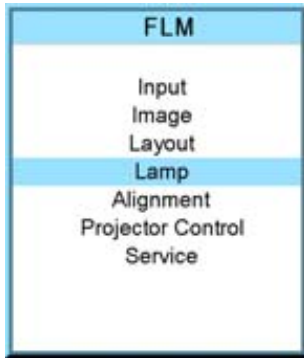

Image 11-1



Image 11-2



Image 11-3

### Remarks

1. When mode is set to [Normal], then CLO mode can be switched *on* and *off*.
2. When switching the power mode to [Economic] while the CLO mode is On, then the CLO mode is switched to Off.
3. When the power mode is [Economic] and the CLO mode is switched to the [On] mode, then the power mode will be switched to the [Normal] mode.

## 11.3 Lamp power

### What can be done?

Within a certain power mode, the light output of the lamp can be reduced.

### How to reduce the lamp power?

1. Press **MENU** to activate the menus.
2. Use the ▲ or ▼ key to select *Lamp* and press **ENTER**.
3. Use the ▲ or ▼ key to select *Power* and press **ENTER**.
4. Use the ▲ or ▼ key to select *Power* and press **ENTER**.
5. Use the ▲ or ▼ key to change the lamp power.

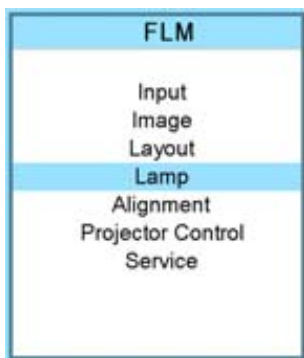

Image 11-4



Image 11-5

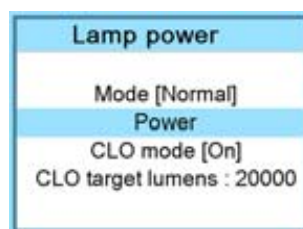

Image 11-6

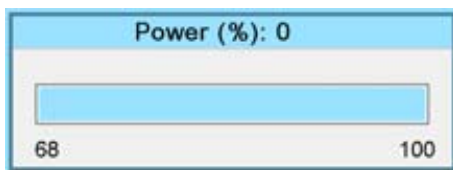

Image 11-7



## 11.4 Lamp Identification

### About

The lamp identification menu gives an overview of the most important parameters of the used lamp.

These parameters are:

- Serial number lamp
- Article number of the used lamp
- Run time since first start up of the lamp
- Remaining run time for a safe operation of the lamp
- Number of strikes since the first start up of the lamp



These parameters are useful when calling for a service intervention.

### How to display?

1. Press **MENU** to activate the menus.
2. Use the **▲** or **▼** key to select *Lamp* and press **ENTER**.
3. Use the **▲** or **▼** key to select *Identification* and press **ENTER**.

The identification overview is displayed.

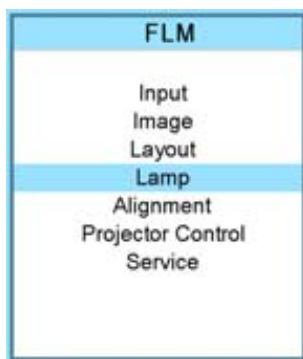

Image 11-8



Image 11-9

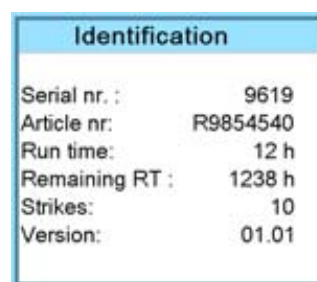

Image 11-10

## 11.5 Z-axis adjustment

### What can be done?

This menu item gives the current light output of the projector. This light output indication can be used to readjust the lamp position in the lamp casing (also called Z-axis adjustment of the lamp). With higher run times, the light output of the lamp will decrease, which results in a lower light output on the screen. This light output decrease can be compensated by readjusting the position of the lamp. For the realignment procedure, see "Realignment of the lamp in its reflector", page 189.

### How to display the light output

1. Press **MENU** to activate the menus.
2. Use the **▲** or **▼** key to select *Lamp* and press **ENTER**.
3. Use the **▲** or **▼** key to select *Z-axis* and press **ENTER**.

## 11. Lamp menu

---

The Z-axis dialog box is display and indicates the current light output..

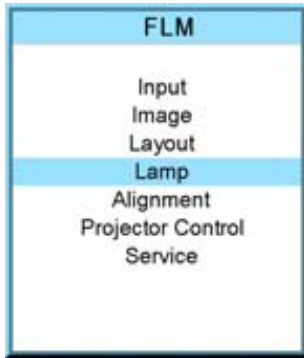

Image 11-11

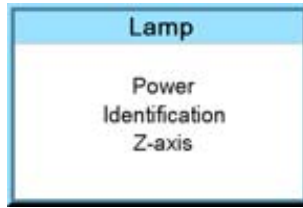

Image 11-12

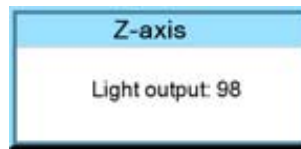

Image 11-13

# 12. ALIGNMENT MENU

## About this chapter

This chapter describes the alignment of the projector once the physical installation is finished. Via the software, the image will be perfectly aligned on the screen.

## Overview

- Overview flow
- Orientation
- Lens adjustment
- Side keystone
- Warp geometry settings
- Contrast enhancement
- Blanking
- Gamma
- Internal pattern
- Color space
- ScenergiX

## 12.1 Overview flow

### Overview

| Level 1   | Level 2              | Level 3   |
|-----------|----------------------|---|
| Alignment |                      |   |
|           | Orientation          | Front Table<br>Front Ceiling<br>Rear Table<br>Rear Ceiling  |
|           | Lens                 | Zoom/Focus<br>Shift<br>Mid position   |
|           | Side keystone        |   |
|           | Warp                 | Horizontal keystone<br>Vertical keystone<br>Rotation<br>Pincushion / Barrel<br>4 corners<br>Load file |
|           | Blanking             | Top<br>Bottom<br>Left<br>Right<br>Reset   |
|           | Contrast enhancement |   |

| Level 1 | Level 2           | Level 3   |
|---------|-------------------|---|
|         | Gamma             |   |
|         | Internal patterns | Checker board<br>Color bars<br>Convergence<br>Focus<br>Full screen black<br>Full screen blue<br>Full screen green<br>Full screen red<br>Full screen white<br>Hatch<br>Outline |
|         | Color space       | Projector<br>EBU<br>SMPTE<br>Custom   |
|         | ScenergiX         | Status<br>White level<br>Black level<br>Show pattern<br>Reset   |

---

## 12.2 Orientation

### What can be done?

The way of physical installation of the projector can be defined to the projector.

The following installation are possible:

- front/table
- front/ceiling
- rear/table
- rear/ceiling

### Set up the correct orientation

1. Press **MENU** to activate the menus.
2. Use the **▲** or **▼** key to select *Alignment* and press **ENTER**.
3. Use the **▲** or **▼** key to select *Orientation* and press **ENTER**.
4. Use the **▲** or **▼** key to select the correct orientation and press **ENTER**.

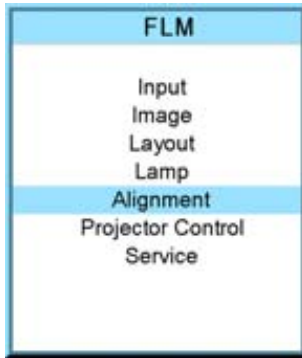

Image 12-1



Image 12-2

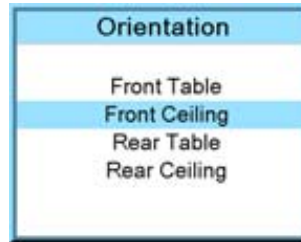

Image 12-3



For more information about the physical installation, see chapter “General”, “Projector configurations”.

## 12.3 Lens adjustment



Quick way to enter the lens adjustment setting; press the lens button on the local keypad or the remote control.

### Access to the lens adjustments

1. Press **MENU** to activate the menus.
2. Use the **▲** or **▼** key to select *Alignment* and press **ENTER**.
3. Use the **▲** or **▼** key to select *Lens* and press **ENTER**.

The lens adjustment menu is displayed.

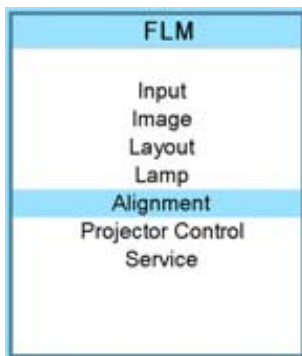

Image 12-4



Image 12-5

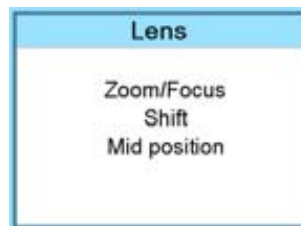

Image 12-6

### Zoom/focus the lens

1. Use the **▲** or **▼** key to select *Zoom/Focus* and press **ENTER**.



Image 12-7

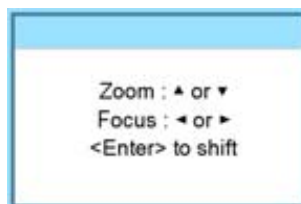

Image 12-8

## 12. Alignment menu

2. Use the ▲ or ▼ key to zoom the lens.  
Use the ◀ or ▶ key to focus the lens.
3. Press **ENTER** to go to the shift adjustments.

### Lens shift

1. Use the ▲ or ▼ key to select *Shift* and press **ENTER** or when in the Zoom/Focus menu press **ENTER** to toggle to the Shift menu.



Image 12-9



Image 12-10

2. Use the ▲ or ▼ key to shift the lens upwards or downwards.  
Use the ◀ or ▶ key to shift the lens to the left or to the right.

### Mid position

1. Use the ▲ or ▼ key to select *Mid position* and press **ENTER**.

The lens will move to its mid position. During this operation, a message is displayed: "Motor running ...".

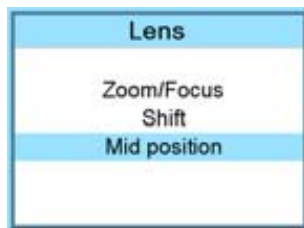

Image 12-11

## 12.4 Side keystone



Only available when the *Warp status* is *Off*.

### What can be done?

The side keystone adjustment is used to align the image if the projector is mounted at a non standard projection angle.



Image 12-12  
Side keystone



- A Keystone adjustment with positive values
- B Keystone adjustment with negative values

### Side keystone adjustment

1. Press **MENU** to activate the menus.

2. Use the ▲ or ▼ key to select *Alignment* and press **ENTER**.
3. Use the ▲ or ▼ key to select *Side keystone* and press **ENTER**.

The keystone dialog box appears.

4. Use the ◀ or ▶ key to adjust the keystone of the image.

When the upper part of the image is wider than the lower part of the image, push the ◀ key. The value below the bar scale will be negative.

When the upper part of the image is smaller than the lower part of the image, push the ▶ key. The value below the bar scale will be positive.

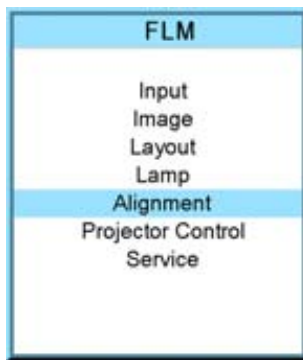

Image 12-13



Image 12-14

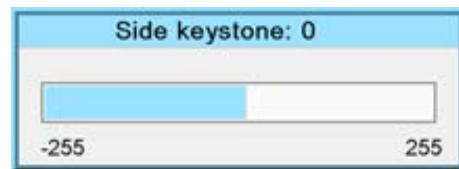

Image 12-15

## 12.5 Warp geometry settings



When the Warp geometry settings are used, the normal side keystone setting is disabled.

### Overview

- About Warp geometry settings
- Warp Status
- Horizontal keystone correction
- Vertical keystone correction
- Rotation
- Pincushion - Barrel correction
- 4 corner correction
- Reset warp settings
- Load warp file

### 12.5.1 About Warp geometry settings

#### Warping

Image warping is the process of digitally manipulating an image such that any shapes portrayed in the image have been significantly distorted. Warping is used for correcting image distortion so that a correct image is displayed.

While an image can be transformed in various ways, pure warping means that points are mapped to points without changing the colors.

Some examples of projected images which need to be corrected with the warp geometry settings:



Image 12-16  
Example 1 : distorted image



Image 12-17  
Example 2 : distorted image



The Warp functions can slow down the switching from one source to another when Input locking is set to automatic and there is a difference in frequency between both sources.

## 12.5.2 Warp Status

### Different modes

The warp distortion can have 3 states:

- Off : no warp distortion can be adjusted. Only the normal Side keystone can be used.
- Manual : the distortion functions inside the projector are available. Combinations of these adjustments can be used to correct the image. When using a setting to correct a part of the image, that can cause that other settings in the menu are grayed out. E.g. Using the keystone functions will gray out the 4 corners setting.
- File : an external created file is used to correct the image. More precise corrections are possible on a lot of more points in the image.

When switching the warp status from *Manual* or *File* to *Off* and back again, the latest used warp settings will be loaded again.

### How to set the status

1. Press **MENU** to activate the menus.
2. Use the **▲** or **▼** key to select *Alignment* and press **ENTER**.
3. Use the **▲** or **▼** key to select *Warp* and press **ENTER**.  
The warp dialog box appears.
4. Use the **▲** or **▼** key to select *Status* and press **ENTER** to toggle between [Manual], [File] or [Off]
  - [Manual] : projector functions for warp are available.
  - [File] : Sophisticated warp adjustments can be loaded via a file. The projector warp functions are not available.
  - [Off] : No warp adjustments used in the projected image.

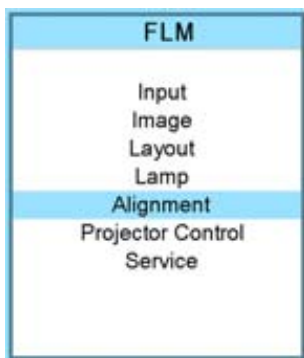

Image 12-18



Image 12-19

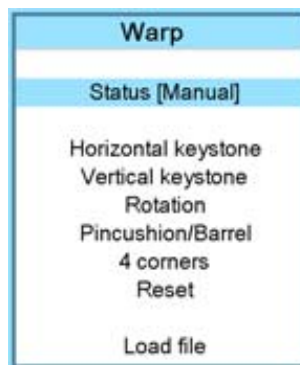

Image 12-20



### 12.5.3 Horizontal keystone correction

#### What can be done?

Horizontal keystone adjustment is used to align the image if the projector is mounted at a non standard projection angle. In some cases, horizontal keystone has to be used in combination with vertical keystone. When adjusting the keystone adjustment, the aspect ratio of the image is not changed.

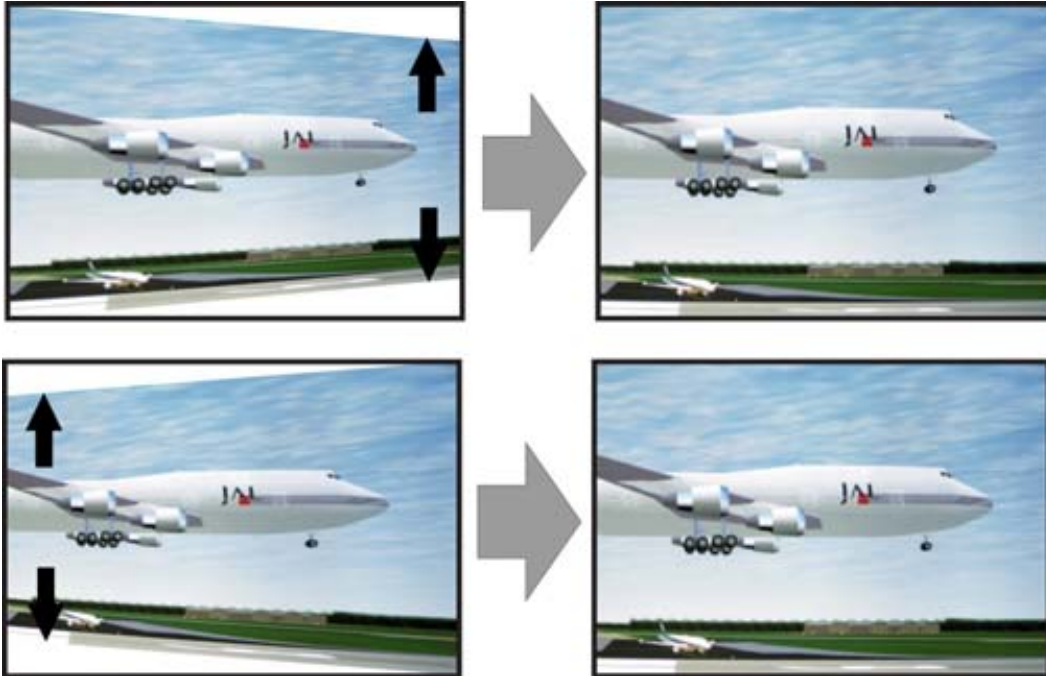

Image 12-21  
Horizontal keystone correction

When the keystone is adjusted, the *4 corners* adjustment is disabled.

#### How to set the status

1. Press **MENU** to activate the menus.
2. Use the **▲** or **▼** key to select *Alignment* and press **ENTER**.
3. Use the **▲** or **▼** key to select *Warp* and press **ENTER**.  
The warp dialog box appears.
4. Use the **▲** or **▼** key to select *Horizontal keystone* and press **ENTER**.
5. Use **◀** or **▶** to change the *horizontal keystone*.

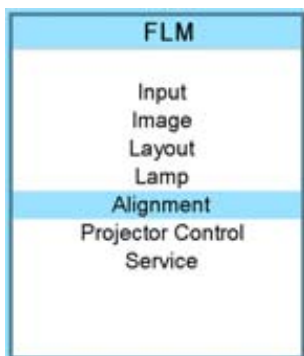

Image 12-22



Image 12-23

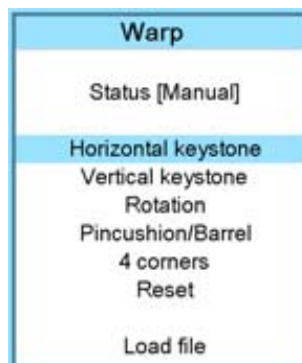

Image 12-24

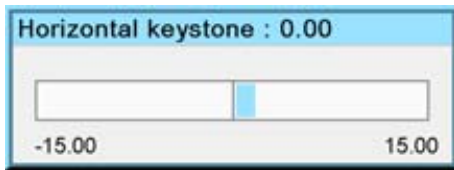

Image 12-25

### 12.5.4 Vertical keystone correction

#### What can be done ?

Vertical keystone adjustment is used to align the image if the projector is mounted at a non standard projection angle. In some cases, vertical keystone has to be used in combination with horizontal keystone. When adjusting the keystone adjustment, the aspect ratio of the image is not changed.

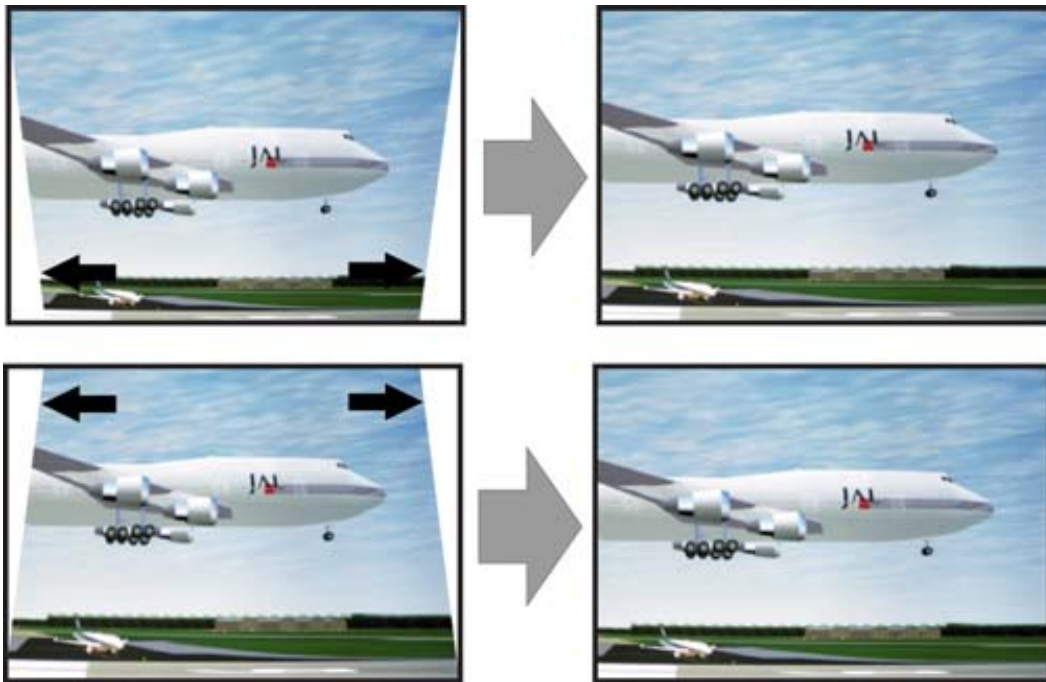

Image 12-26  
Vertical keystone correction

When the keystone is adjusted, the *4 corners* adjustment is disabled.

#### How to set the status

1. Press **MENU** to activate the menus.
2. Use the **▲** or **▼** key to select *Alignment* and press **ENTER**.
3. Use the **▲** or **▼** key to select *Warp* and press **ENTER**.  
The warp dialog box appears.
4. Use the **▲** or **▼** key to select *Vertical keystone* and press **ENTER**.
5. Use **◀** or **▶** to change the *vertical keystone*.

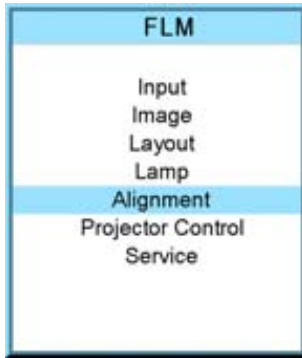

Image 12-27



Image 12-28

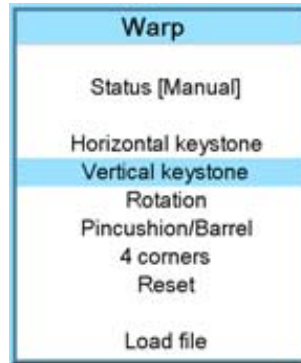

Image 12-29

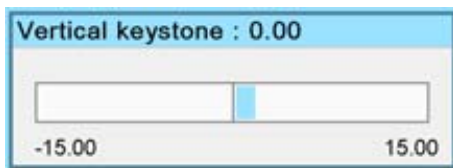
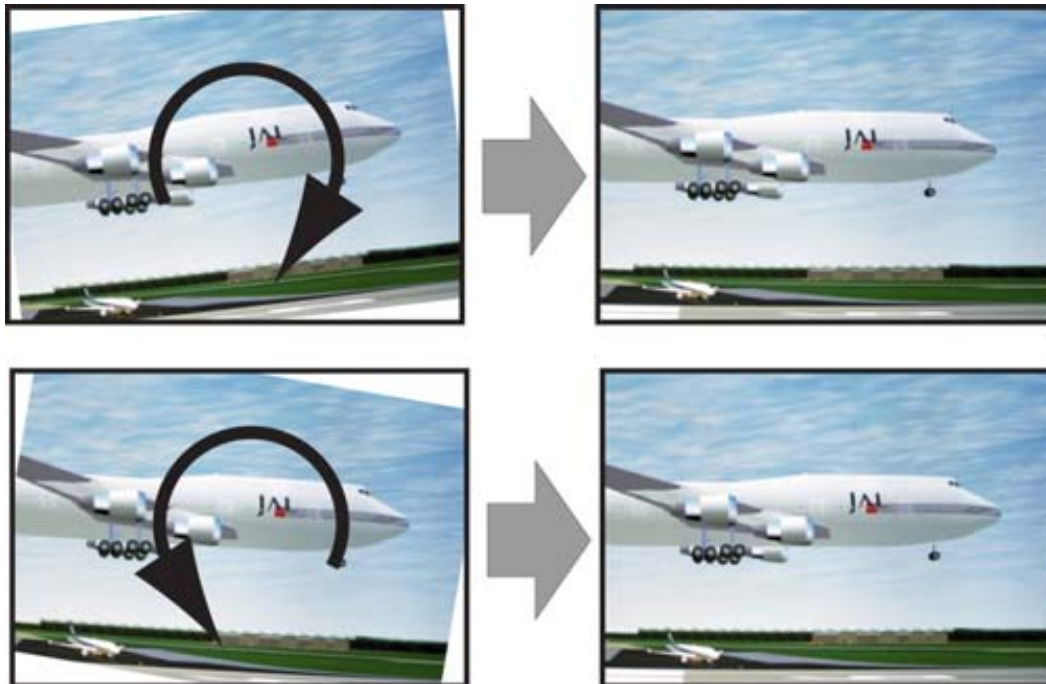

Image 12-30

### 12.5.5 Rotation

#### What can be done ?

A rotation is used to turn the image on the projection surface when the projector is slightly rotated around its axes.

Image 12-31  
Rotation

#### How to rotate

1. Press **MENU** to activate the menus.
2. Use the **▲** or **▼** key to select *Alignment* and press **ENTER**.
3. Use the **▲** or **▼** key to select *Warp* and press **ENTER**.  
The warp dialog box appears.
4. Use the **▲** or **▼** key to select *Rotation* and press **ENTER**.
5. Use **◀** or **▶** to change the *rotation angle*.

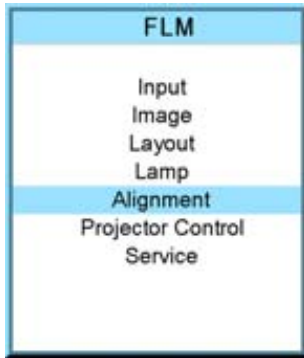

Image 12-32



Image 12-33

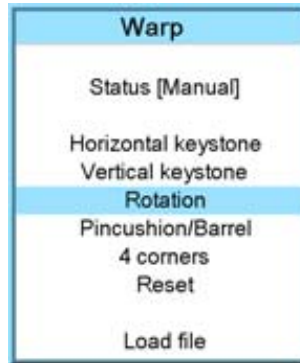

Image 12-34

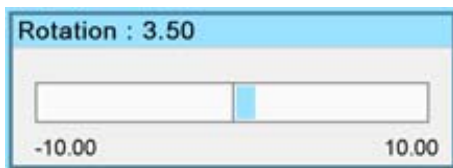

Image 12-35

### 12.5.6 Pincushion - Barrel correction

#### What can be done ?

A barrel distortion or pincushion distortion can be adjusted so that a normal image is displayed. Positive adjustments introduce more barrel distortion. Negative adjustments introduce more pincushion distortion.

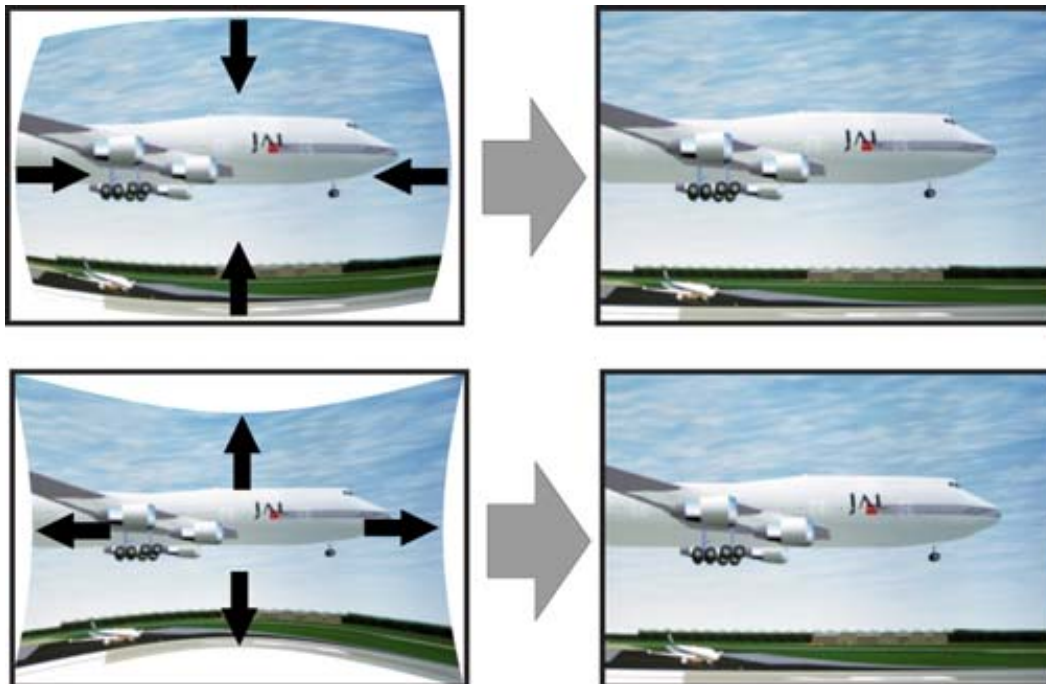

Image 12-36  
Barrel and pincushion distortion

#### How to correct the distortion

1. Press **MENU** to activate the menus.
2. Use the **▲** or **▼** key to select *Alignment* and press **ENTER**.
3. Use the **▲** or **▼** key to select *Warp* and press **ENTER**.  
The warp dialog box appears.
4. Use the **▲** or **▼** key to select *Pincushion/Barrel* and press **ENTER**.
5. Use **◀** or **▶** to adjust the pincushion or the barrel distortion.

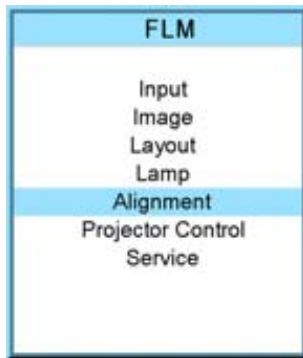

Image 12-37



Image 12-38

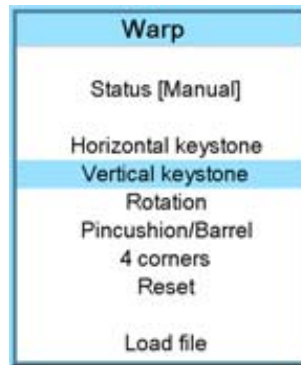

Image 12-39



Image 12-40

### 12.5.7 4 corner correction

#### What can be done ?

Each corner of the image can be moved individually in the X and Y direction to correct a distortion. Take in account that the aspect ratio can be changed while moving one of the corners.

The following adjustments are possible:

- Top left X
- Top left Y
- Top right X
- Top right Y
- Bottom left X
- Bottom left Y
- Bottom right X
- Bottom right Y

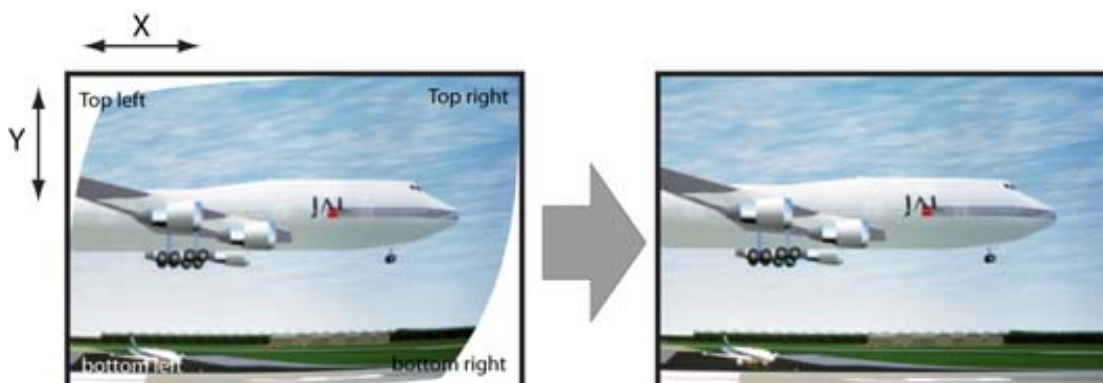

Image 12-41

Once an adjustment is done in one of the 4 corners, the horizontal and vertical keystone corrections are disabled.

#### How to move a corner

1. Press **MENU** to activate the menus.
2. Use the **▲** or **▼** key to select *Alignment* and press **ENTER**.
3. Use the **▲** or **▼** key to select *Warp* and press **ENTER**.  
The warp dialog box appears.
4. Use the **▲** or **▼** key to select *4 corners* and press **ENTER**.



## 12. Alignment menu

5. Use the ▲ or ▼ key to select a corner and press **ENTER**.
6. Use ▲ or ▼ key to move the selected point in the X position and use ◀ or ▶ key to move the selected point in the Y position.

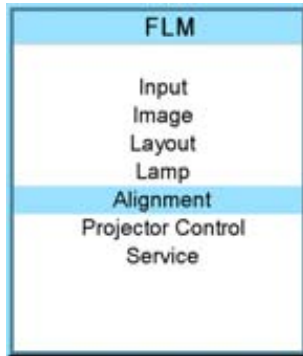

Image 12-42



Image 12-43

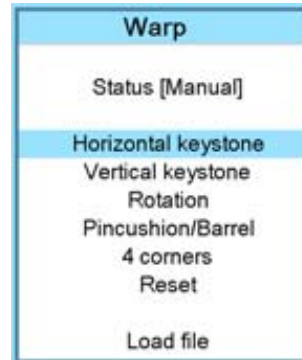

Image 12-44

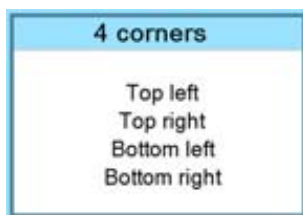

Image 12-45

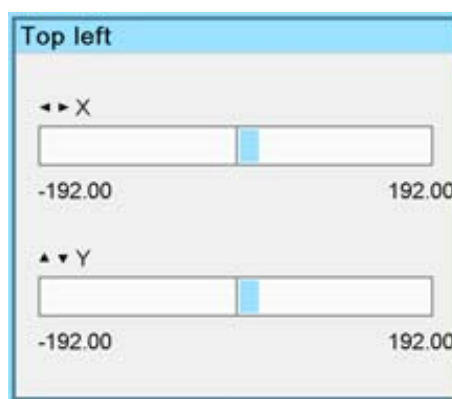

Image 12-46

### 12.5.8 Reset warp settings

#### What can be done ?

The current warp settings can be reset or returned to zero (0). At that moment all functions within the warping menu are available again.

#### How to correct the distortion

1. Press **MENU** to activate the menus.
2. Use the ▲ or ▼ key to select *Alignment* and press **ENTER**.
3. Use the ▲ or ▼ key to select *Warp* and press **ENTER**.  
The warp dialog box appears.
4. Use the ▲ or ▼ key to select *Reset* and press **ENTER**.  
All warp settings are reset. The *Status* is set to [Off].

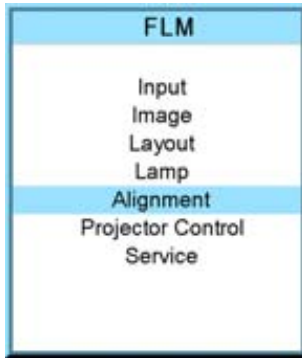

Image 12-47



Image 12-48

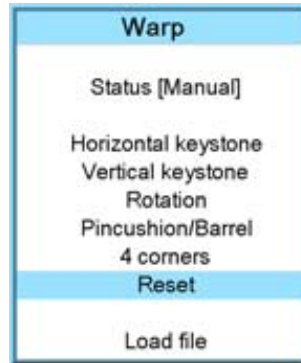

Image 12-49

## 12.5.9 Load warp file

### What can be done ?

Special corrections which are not possible with the functions inside the projector are possible by loading a file which contains these corrections. This file should be created on an external computer and then stored on the projector using Projector Toolset. For more information about a free download of Projector Toolset, see "Free download of Projector Toolset", page 18.

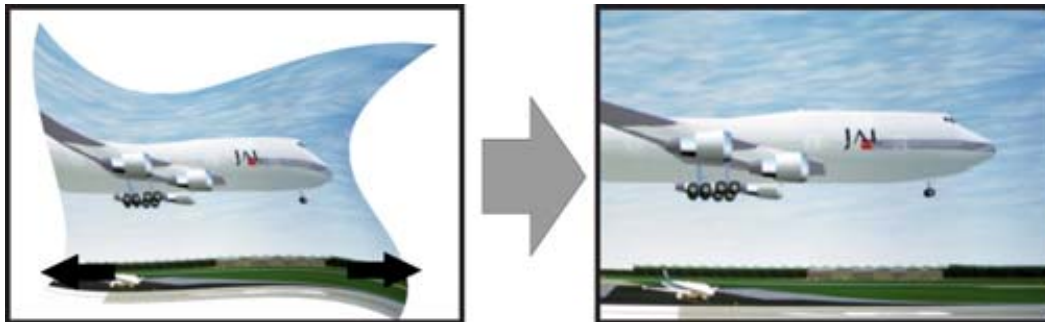

Image 12-50

### How to load a file

1. Press **MENU** to activate the menus.
2. Use the **▲** or **▼** key to select *Alignment* and press **ENTER**.
3. Use the **▲** or **▼** key to select *Warp* and press **ENTER**.  
The warp dialog box appears.
4. Use the **▲** or **▼** key to select *Load file* and press **ENTER**.  
The load file menu opens
5. Use the **▲** or **▼** key to select the desired file out of the list and press **ENTER**.  
The file is loaded and the corrections are applied.

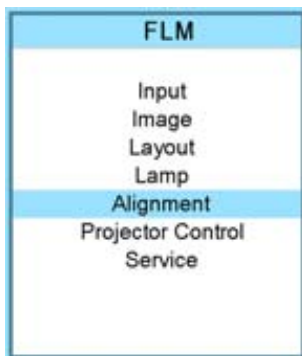

Image 12-51



Image 12-52

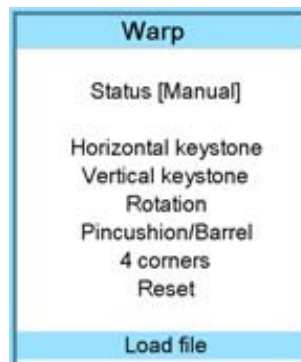

Image 12-53



Image 12-54

## 12.6 Contrast enhancement

---

### Purpose

Increase the contrast for all video and data sources.

### How to change

1. Press **MENU** to activate the menus.
2. Use the **▲** or **▼** key to select *Alignment* and press **ENTER**.
3. Use the **▲** or **▼** key to select *Contrast enhancement* and press **ENTER**.

The current selected contrast setting is indicated with an arrow.

4. Use the **▲** or **▼** key to select the desired setting and press **ENTER**.

The following settings are possible:

Normal contrast

High contrast

Custom

any value between normal and high contrast can be selected.

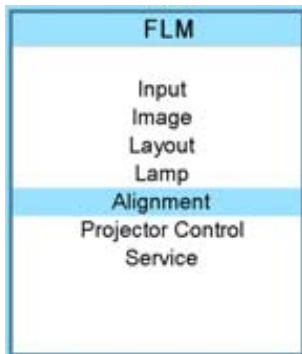

Image 12-55



Image 12-56



Image 12-57

5. When *Custom* is selected, the contrast menu is displayed.
6. Use the **▲** or **▼** key to select the desired adjustment and press **ENTER**. Press **EXIT** to return.

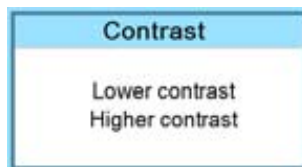

Image 12-58

## 12.7 Blanking

---

### What can be done ?

Blanking adjustments affect only the edges of the projected image and are used to frame the projected image on to the screen and to hide or black out unwanted information (or noise). A '0' on the bar scale indicates no blanking.



### Which blanking adjustments are available ?

- top blanking
- bottom blanking
- left blanking
- right blanking

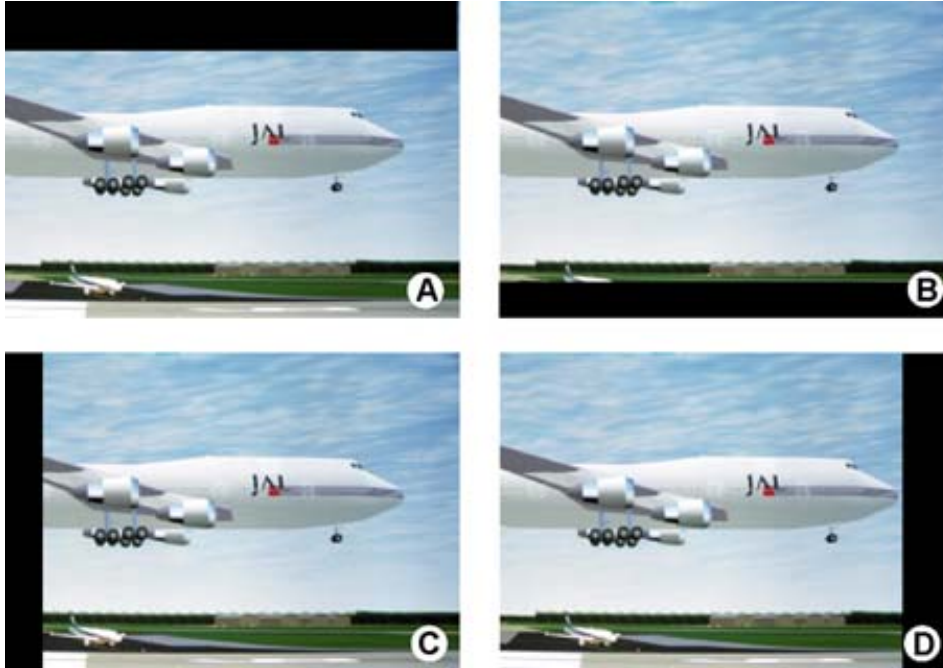

Image 12-59  
Blanking

- A Top blanking
- B Bottom blanking
- C Left blanking
- D Right blanking

The reset function brings all blanking settings back to zero.

### How to adjust the blanking?

1. Press **MENU** to activate the menus.
2. Use the **▲** or **▼** key to select *Alignment* and press **ENTER**.
3. Use the **▲** or **▼** key to select *Blanking* and press **ENTER**.
4. Use the **▲** or **▼** key to select the desired blanking adjustment and press **ENTER**.
5. Use the **▲** or **▼** key to adjust until the desired blanking is reached.
6. Press **EXIT** to return.

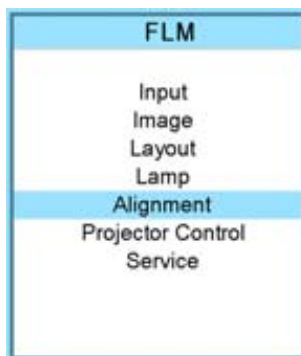

Image 12-60



Image 12-61



Image 12-62

## 12.8 Gamma

### About Gamma

Gamma is an image quality enhancement function that offers a richer image by brightening the already darker portions of the image without altering the brightness of the brighter portions (contrast feeling enhanced).

### How to adjust gamma?

1. Press **MENU** to activate the menus.
2. Use the **▲** or **▼** key to select *Alignment* and press **ENTER**.
3. Use the **▲** or **▼** key to select *Gamma* and press **ENTER**.  
The Gamma progress bar appears.
4. Use **◀** or **▶** key to change the gamma setting and press **EXIT**.  
Gamma can be set to one of the 8 available steps.

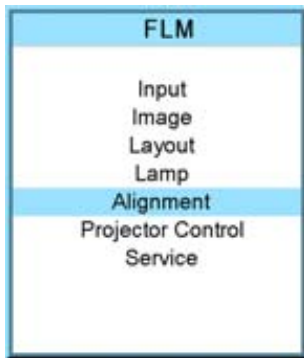

Image 12-63



Image 12-64

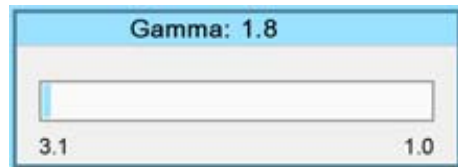

Image 12-65

## 12.9 Internal pattern

### What can be done with these patterns?

The projector is equipped with different internal patterns which can be used for measurement and alignment purposes.

### How to select?

1. Press **MENU** to activate the menus.
2. Use the **▲** or **▼** key to select *Alignment* and press **ENTER**.
3. Use the **▲** or **▼** key to select *Internal patterns* and press **ENTER**.  
The internal patterns menu is displayed.
4. Use the **▲** or **▼** key to scroll through the possible selection and press **ENTER** to activate the selected pattern.  
Select **▲** or **▼** in the menu to display the previous or next page with possible internal patterns.

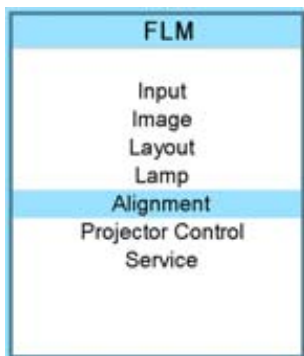

Image 12-66



Image 12-67

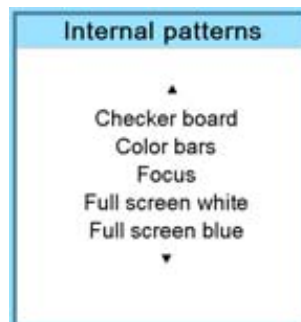

Image 12-68

The selected pattern is displayed.  
The following patterns are available:

- Checker board
- Color bars
- Convergence
- Focus
- Full screen black
- Full screen blue
- Full screen green
- Full screen red
- Full screen white
- Hatch
- Outline
- Purity
- ScenergiX

## 12.10 Color space



### Color space

A color space or color standard is a mathematical representation for a color. For example the RGB color space is based on a Cartesian coordinate system.

### What can be adjusted ?

The color space (gamut), the collection of colors which can be reproduced by the projector, can be adjusted to 4 predefined stored values (one projector specific, 2 international standards and one custom preset). A temporary custom adjustment is possible. The maximum color space which can be displayed is the projector color space. This color space is measured at the factory and stored inside the projector.

### How to select a color standard?

1. Press **MENU** to activate the menus.
2. Use the **▲** or **▼** key to select *Alignment* and press **ENTER**.
3. Use the **▲** or **▼** key to select *Color space* and press **ENTER**.
4. Use the **▲** or **▼** key to select the [On] or [Off] selection and **ENTER** to toggle color space on or off.
5. When color space is [On], use the **▲** or **▼** key to select the desired color standard and press **ENTER** to activate. Use the **►** key to view the details or to edit the details when Custom is selected.

Projector    Maximum color space

EBU         European Broadcasting Union. This organization defines a European standard.

SMPTE      American standard.

Custom     The user can define the x and y coordinates for red, green and blue which forms the corners of the color space. By changing the coordinates, the color reproduction can be changed.

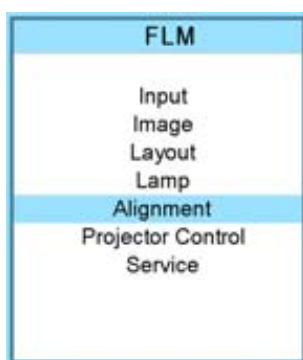

Image 12-69



Image 12-70

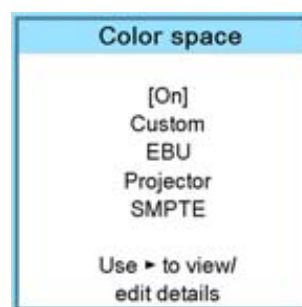

Image 12-71

## 12. Alignment menu

6. When custom is selected, use the ► key to view the details. To adjust the custom values, select the desired color point using the ▲ or ▼ key and change the value with ◀ or ▶ key until the desired value is reached. When finished, press **EXIT** to return.

| Color space 'custom' details |       |
|------------------------------|-------|
| Red x                        | 0.638 |
| Red y                        | 0.351 |
| Green x                      | 0.370 |
| Green y                      | 0.597 |
| Blue x                       | 0.146 |
| Blue y                       | 0.054 |
| White y                      | 0.340 |
| Use ◀ or ▶ to change a value |       |

Image 12-72

## 12.11 ScenergiX

### Overview

- Introduction
- Preparations
- ScenergiX activation
- ScenergiX overlap zone (horizontal ScenergiX)
- ScenergiX overlap zone (vertical ScenergiX)
- ScenergiX size adjustment (White level)
- Adjusting the black level of the images

### 12.11.1 Introduction

#### Why ScenergiX ?

When working in a multichannel setup the FLM HD20 and its Soft Edge possibilities enable an image blending that gives the appearance of a single view, thus achieving realistic immersion for the majority of wide screen applications.



Image 12-73  
Why Soft Edge?

#### What is the Basic Principal of ScenergiX ?

The principle of edge blending is achieved by linear modulation of the light output in the overlap zone so that the light output in that zone equals the light output of the rest of the image.

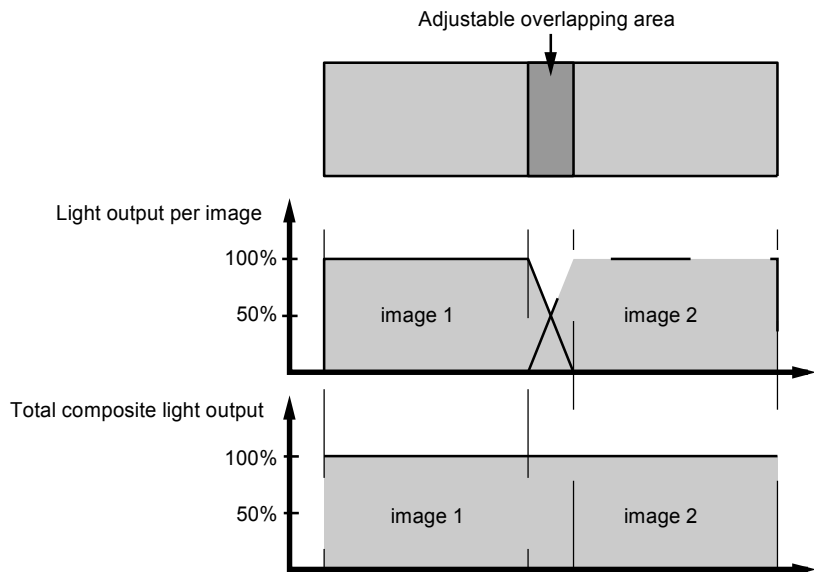

Image 12-74  
ScenergiX Basic Principle

### 12.11.2 Preparations

#### ScenergiX Preparations

To ensure proper ScenergiX adjustment, be sure that the following adjustments are done perfectly on all projectors:

- Convergence
- Geometry
- Color Matching (Color Temperature, Color Standard, Input Balance, Gamma)

### 12.11.3 ScenergiX activation

#### How to activate?

1. Press **MENU** to activate the menus.
2. Use the **▲** or **▼** key to select *Alignment* and press **ENTER**.
3. Use the **▲** or **▼** key to select *ScenergiX* and press **ENTER**.
4. Use the **▲** or **▼** key to select *Status* and press **ENTER** to toggle between [On] and [Off].

- On        ScenergiX is active
- Off       ScenergiX is not active

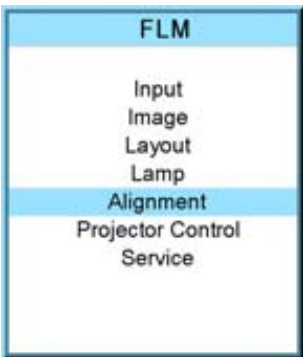

Image 12-75



Image 12-76

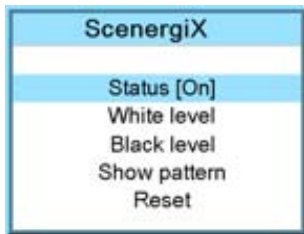

Image 12-77

### 12.11.4 ScenergiX overlap zone (horizontal ScenergiX)

#### Definitions

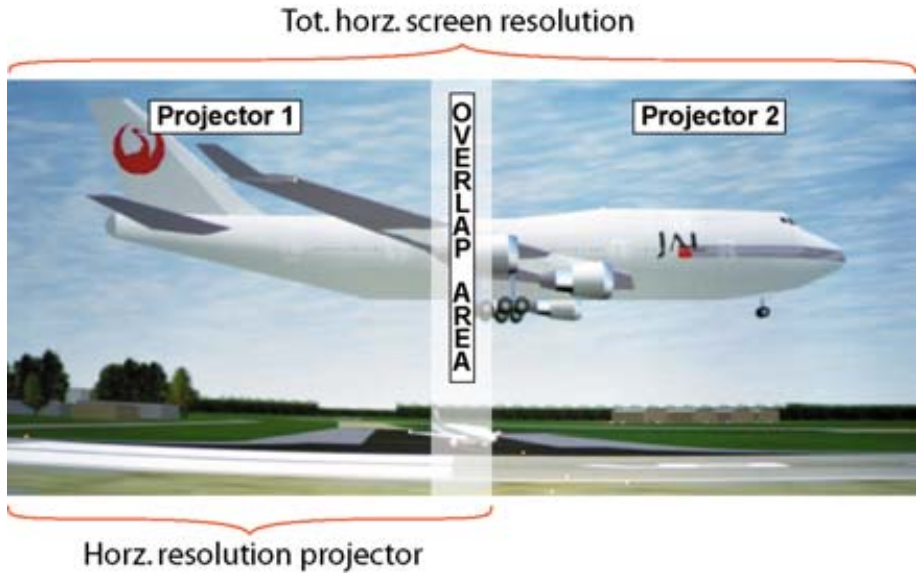

Image 12-78  
ScenergiX set up

Overlap : number of pixels that overlap

Horizontal resolution of 1 projector

Total horizontal screen resolution : [(horizontal resolution of 1 projector) x 2] minus overlap.

Horizontal Resolution source : number of active pixels of the source.

#### How to set for the first projector

1. Go to *Layout* → *Main window* → *Size*
2. Enter the value for the Width as follow: Total horizontal screen resolution / 2 - 0.5 x overlap zone.
3. Position remains the same.

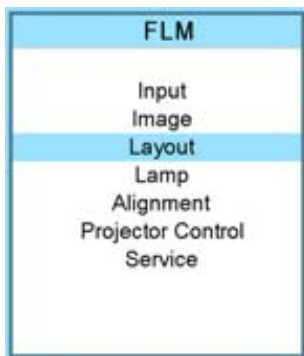

Image 12-79

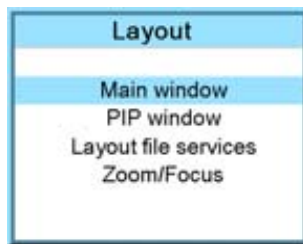

Image 12-80

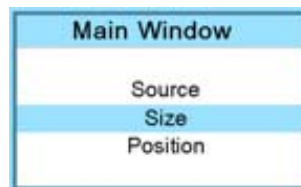

Image 12-81

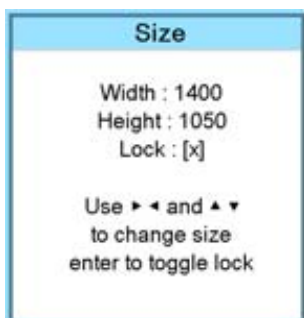

Image 12-82

### How to set for the second projector

1. Go to *Layout* → *Main window* → *Size*
2. Enter the value for the Width as follow: Total horizontal screen resolution / 2 - 0.5 x overlap zone.
3. Position = original start + horizontal width of projector 1 - overlap zone

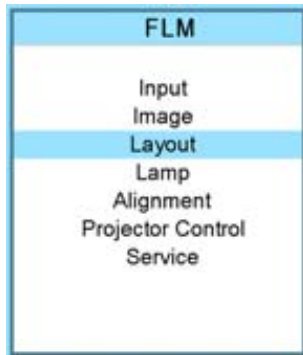

Image 12-83

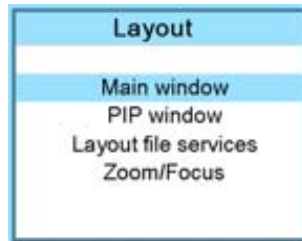

Image 12-84

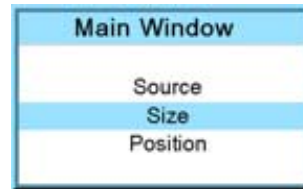

Image 12-85

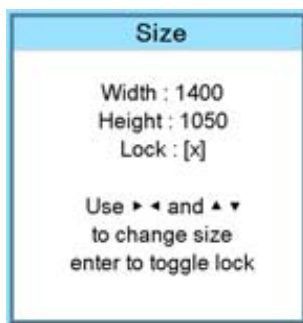

Image 12-86



Image 12-87

### 12.11.5 ScenergiX overlap zone (vertical ScenergiX)

#### Definitions

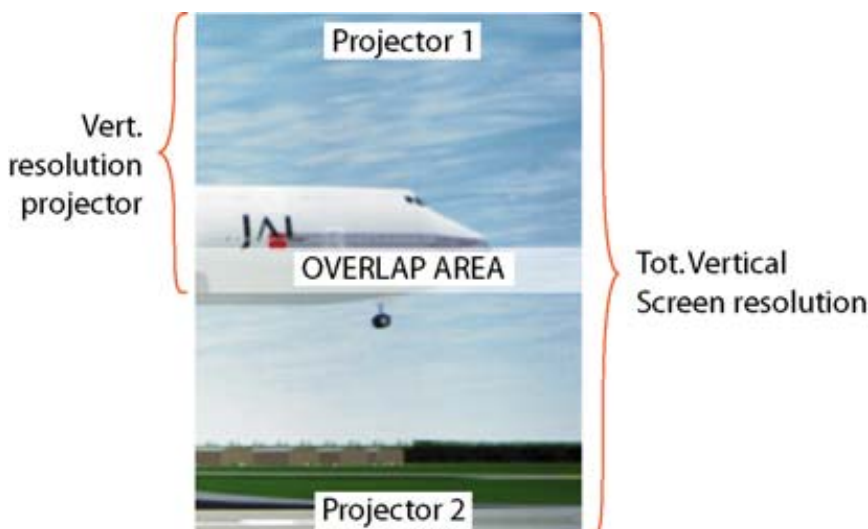

Image 12-88  
ScenergiX overlap zone vertical

Overlap : number of pixels that overlap

Vertical resolution of 1 projector

Total vertical screen resolution : [(Vertical resolution of 1 projector) x 2] minus (overlap)

Vertical Resolution source : number of active lines of the source



**How to set for the first projector**

1. Go to *Layout* → *Main window* → *Size*
2. Enter the value for the Height as follow: Total Vertical screen resolution / 2 - 0.5 x overlap zone.
3. Position remains the same.

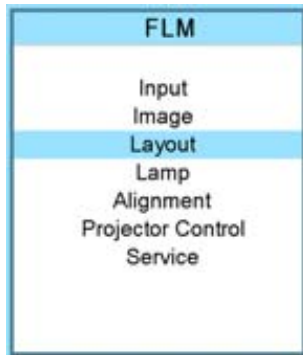

Image 12-89

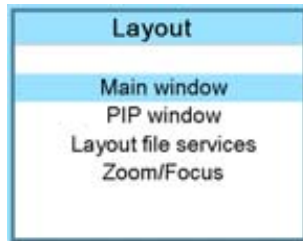

Image 12-90

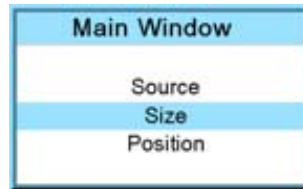

Image 12-91

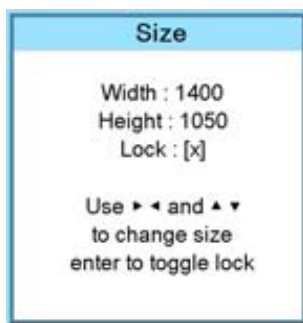

Image 12-92

**How to set for the second projector**

1. Go to *Layout* → *Main window* → *Size*
2. Enter the value for the Width as follow: Total Vertical screen resolution / 2 - 0.5 x overlap zone.
3. Position = original start + Vertical height projector 1 - overlap zone

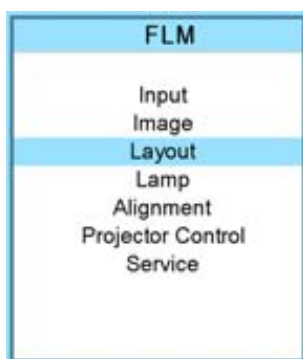

Image 12-93

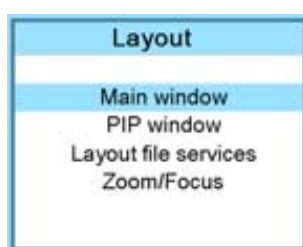

Image 12-94

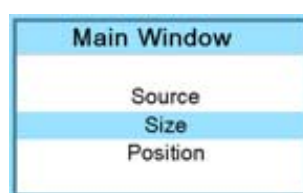

Image 12-95



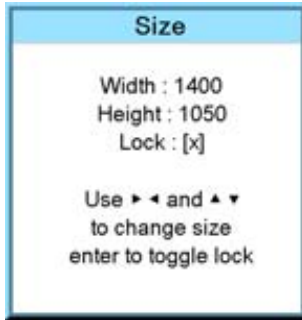

Image 12-96



Image 12-97

### 12.11.6 ScenergiX size adjustment (White level)

#### What can be done with the white level menu?

The white level menu contains top, bottom, left or right item to set the blending zone.



The ScenergiX menu items are only accessible when status is [On].

#### How to set the blending zone?

1. Press **MENU** to activate the menus.
2. Use the **▲** or **▼** key to select *Alignment* and press **ENTER**.
3. Use the **▲** or **▼** key to select *ScenergiX* and press **ENTER**.
4. Use the **▲** or **▼** key to select *White level* and press **ENTER**.
5. Use the **▲** or **▼** key to select one of the four size adjustments and press **ENTER**.

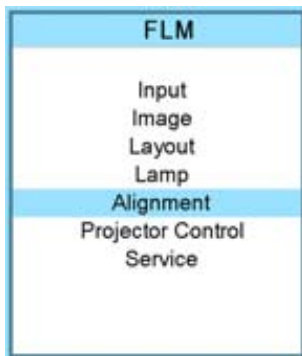

Image 12-98



Image 12-99

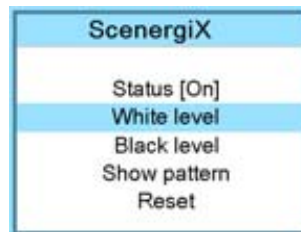

Image 12-100



Image 12-101

## 12. Alignment menu

A pattern with the different areas is displayed.

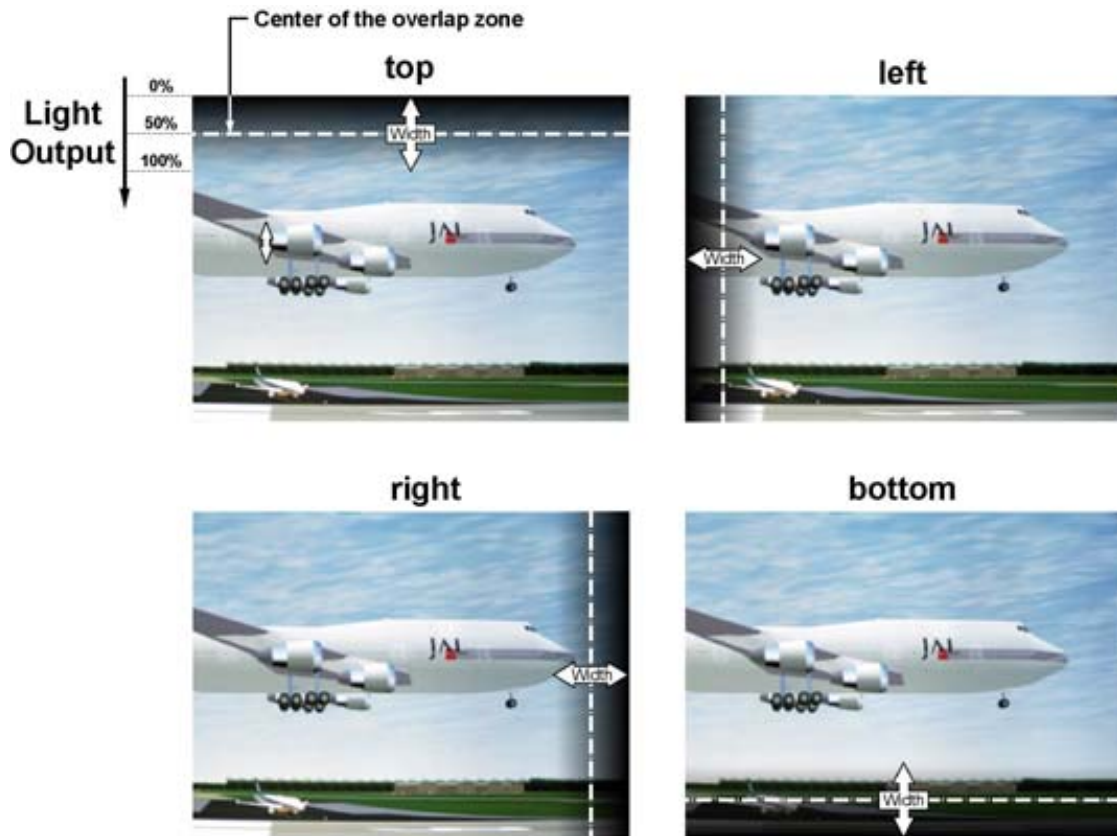

Image 12-102  
Width selections

6. Use the cursor keys to move the border of the overlap area to the desired position. Set first the width for the first projector and repeat for the second one.

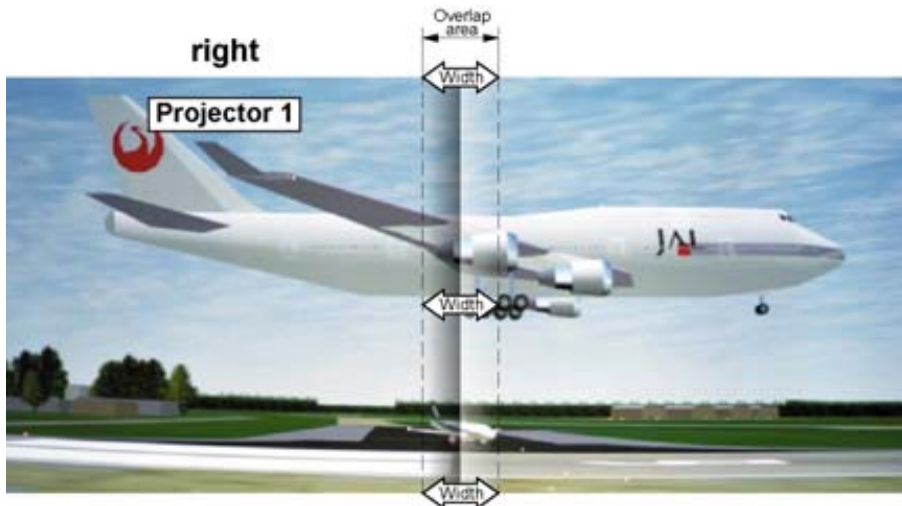

Image 12-103  
Width set up for projector 1

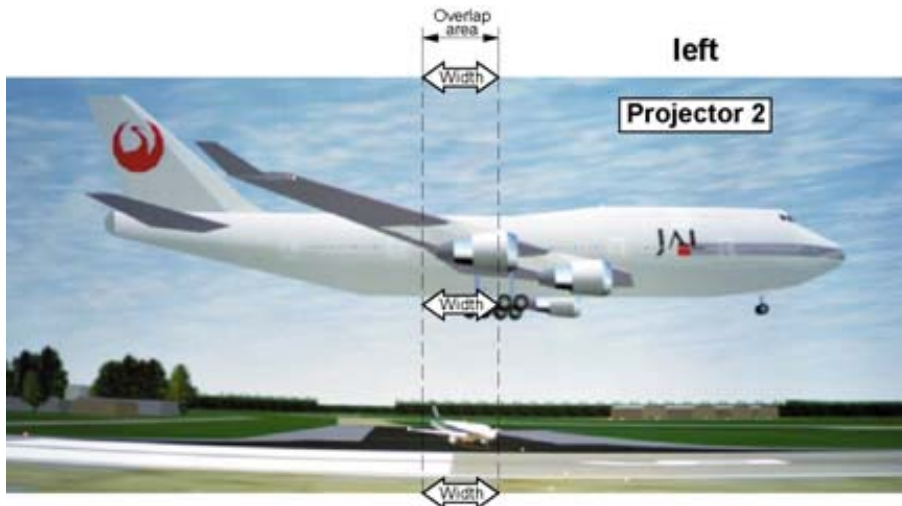

Image 12-104  
Width set up for projector 2

### 12.11.7 Adjusting the black level of the images

#### Why black level adjustment

For dark images, the overlap zone will be brighter than the rest of the images. Typically for DLP projectors, next to the overlap zone, a brighter area is recognized. This area is known as a DLP leakage area. This area must also be excluded for the black level adjustment. Therefore we can rise the black level of the remaining image (excluding the overlap zone and the DLP leakage area).

First, the width of the leakage area must be set. The white cursor line indicates the border of the overlap area. The green cursor line indicates the current installed DLP leakage area border and starts at the position of the white cursor line (no width installed). This green line can be moved to the border of the DLP leakage area with the cursor keys.

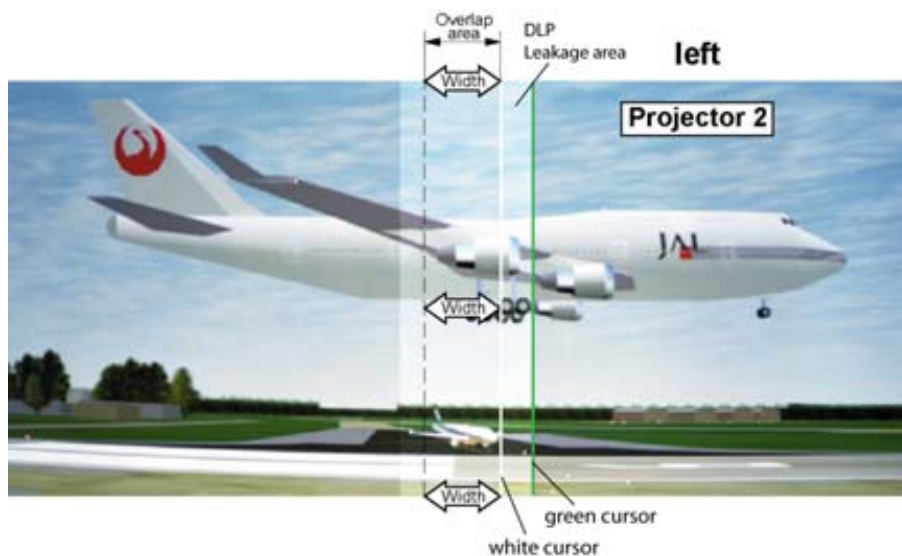

Image 12-105  
DLP Leakage area set up



After the area is set, use **TEXT** key to remove the area border lines when adjusting the black level.

#### How to set the leakage area width

1. Press **MENU** to activate the menus.
2. Use the **▲** or **▼** key to select *Alignment* and press **ENTER**.
3. Use the **▲** or **▼** key to select *ScenergiX* and press **ENTER**.
4. Use the **▲** or **▼** key to select *Black level* and press **ENTER**.

## 12. Alignment menu

5. Use the ▲ or ▼ key to select one of the four size adjustments and press **ENTER**.

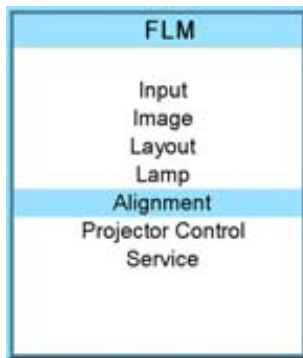

Image 12-106



Image 12-107

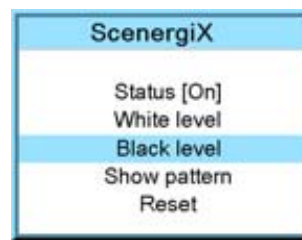

Image 12-108



Image 12-109

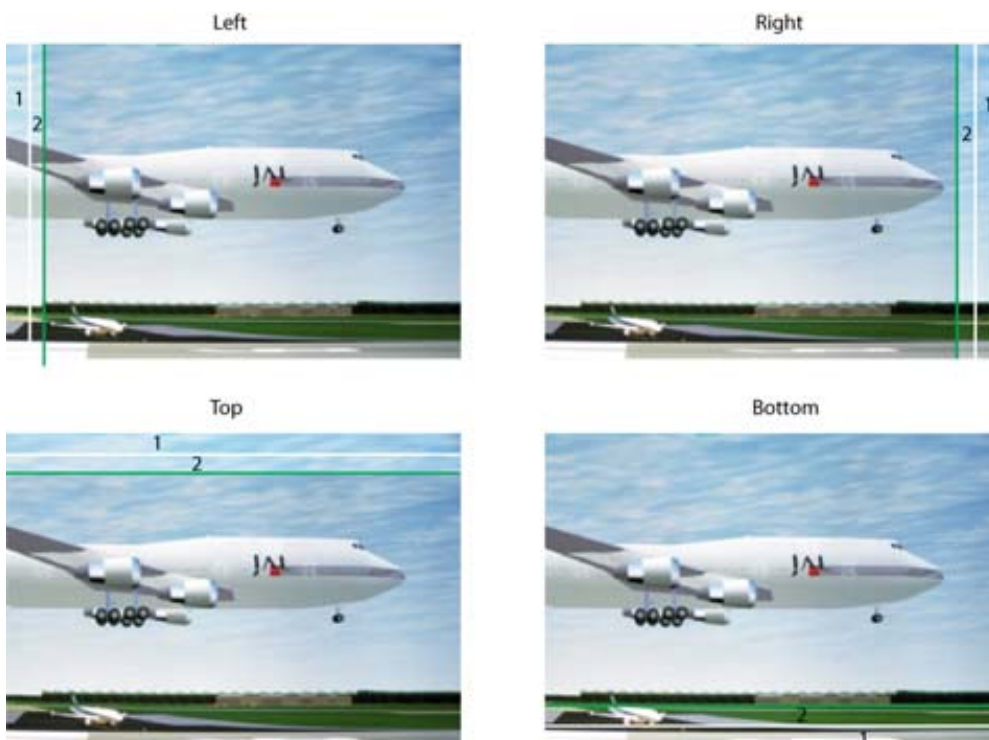

Image 12-110  
DLP leakage area

- 1 Overlap area
- 2 DLP Leakage area

6. Use the cursor keys to move the green border line to the desired position.

The leakage area for this overlap is defined and will be excluded during black level adjustment.

### How to adjust

1. Press **MENU** to activate the menus.
2. Use the **▲** or **▼** key to select *Alignment* and press **ENTER**.
3. Use the **▲** or **▼** key to select *ScenergiX* and press **ENTER**.
4. Use the **▲** or **▼** key to select *Black level* and press **ENTER**.

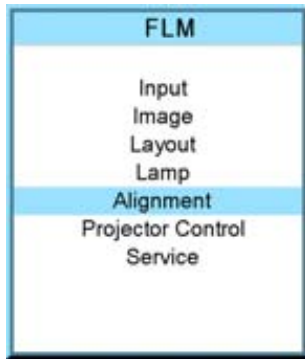

Image 12-111



Image 12-112

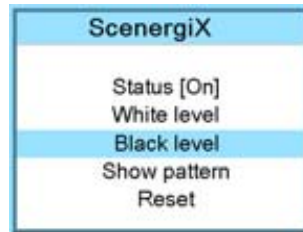

Image 12-113



Image 12-114

5. Adjust the black level of area A until the black level of area A, B and C are equal. Use the Adjust function All, Red, Green and Blue in the Black level menu.

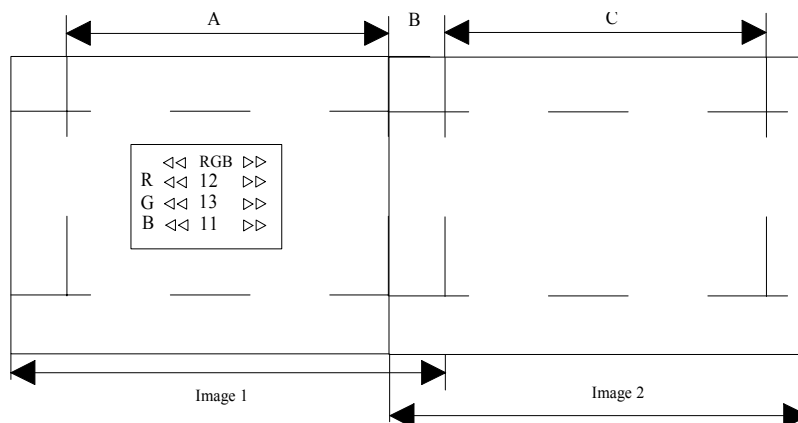

Image 12-115  
Black level adjustment



Use the **Reset** function to bring all ScenergiX settings back to zero.



# 13. PROJECTOR CONTROL

## About this chapter

This chapter explains the setup of the control part of the software such as projector address and all types of communication with the external world.

## Overview

- Overview flow
- Projector address
- Serial communication
- Network
- IR control switching
- Art-Net DMX
- Buttons
- Menu position
- Local LCD
- Language selection

## 13.1 Overview flow

### Overview

| Level 1           | Level 2              | Level 3   |
|-------------------|----------------------|---|
| Projector control | Projector address    | Projector address<br>Common address   |
|                   | Serial communication | Baud rate [115200]<br>Interface standard [RS232/RS422]<br>RS422 termination [Off/On]                          |
|                   | Network              | DHCP [ON/OFF]<br>IP-address<br>Subnet mask<br>Default gateway   |
|                   | IR control           | IR Front [On/Off]<br>IR Back [On/Off]<br>IR Side [On/Off]   |
|                   | ART DMX              | DMX address<br>DMX universe<br>DMX monitor<br>DMX mode [Basic/Extended/Full]<br>Home lens at startup [No/Yes] |
|                   | Buttons              | Standby<br>APA  |

| Level 1 | Level 2       | Level 3   |
|---------|---------------|---|
|         |               | Shortcut keys   |
|         | Menu position | Menu<br>Bar scale                                     |
|         | Local LCD     | Local LCD time out<br>Local LCD contrast              |
|         | Language      | English<br>Français<br>Deutsch<br>Español<br>Italiano |

---

## 13.2 Projector address

---

### Overview

- Individual projector address
- Common address

### 13.2.1 Individual projector address

#### About individual projector address

Before a projector, and only this projector, can be controlled via a remote control, an individual address must be entered in the projector.

This individual projector address can then be used to control the projector via remote control or via a serial connection.

Next to an individual projector address, each projector has also a common address for group control.

#### How to set an individual address?

1. Press **MENU** to activate the menus.
2. Use the **▲** or **▼** key to select *Projector control* and press **ENTER**.
3. Use the **▲** or **▼** key to select *Projector address* and press **ENTER**.
4. Use the **▲** or **▼** key to select *Projector Address* and press **ENTER**.  
The edit projector address window opens.
5. Use the **▲** or **▼** key to select a new value  
Or,  
enter a new value with the digit keys on the remote control or local keypad.
6. Use the **◀** or **▶** key to select the next digit and repeat step 5.
7. When the desired address is entered, press **ENTER** to store that address.



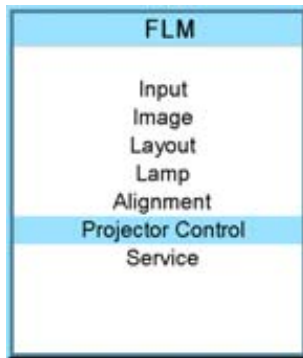

Image 13-1

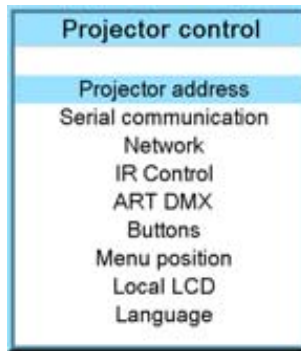

Image 13-2

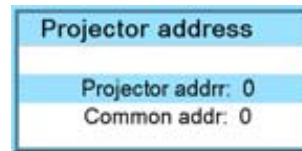

Image 13-3

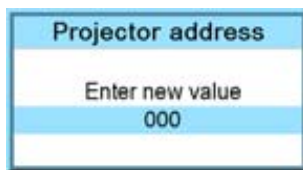

Image 13-4

## 13.2.2 Common address

### About common address

A common address can be '0' or '1'.

Any command coming from a remote control programmed with that common address will be executed.

### How to change the common address?

1. Press **MENU** to activate the menus.
2. Use the **▲** or **▼** key to select *Projector control* and press **ENTER**.
3. Use the **▲** or **▼** key to select *Projector address* and press **ENTER**.
4. Use the **▲** or **▼** key to select *Common address* and press **ENTER**.

The edit common address window opens.

5. Use the **▲** or **▼** key to select '0' or '1'  
Or,  
enter '0' or '1' with the digit keys on the remote control or local keypad.
6. When the desired address is entered, press **ENTER** to store that address.

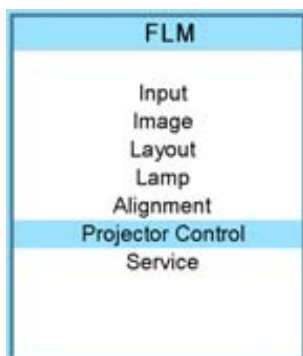

Image 13-5

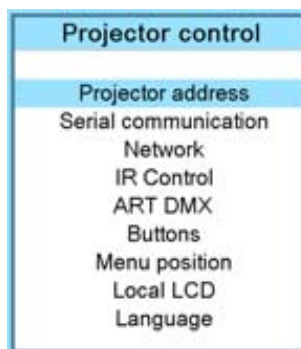

Image 13-6

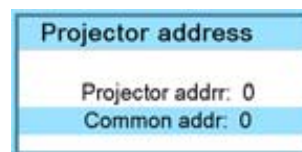

Image 13-7

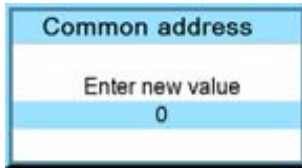

Image 13-8

## 13.3 Serial communication

---

### Overview

- Baud rate setup
- Interface standard
- RS422 termination

### 13.3.1 Baud rate setup

#### What can be done?

The baudrate for a serial connection with a computer can be set up.

#### How to set up?

1. Press **MENU** to activate the menus.
2. Use the ▲ or ▼ key to select *Projector control* and press **ENTER**.
3. Use the ▲ or ▼ key to select *Serial communication* and press **ENTER**.  
The serial communication menu opens.
4. Use the ▲ or ▼ key to select *Baudrate* and press **ENTER** to toggle between the available baud rates.  
The following baud rates can be selected:
  - 9600
  - 19200
  - 38400
  - 57600
  - 115200
5. Press **EXIT** to return.

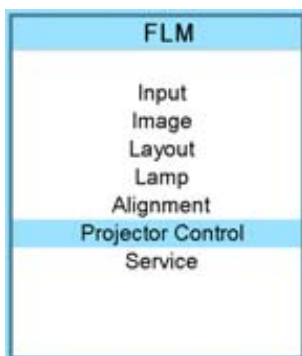

Image 13-9



Image 13-10

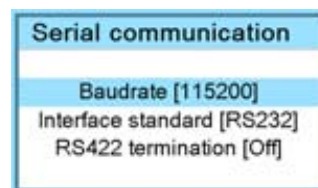

Image 13-11

### 13.3.2 Interface standard

#### What can be done?

The communication protocol for the communication between the projector and a computer can be set to RS232 or RS422.

#### How to set up

1. Press **MENU** to activate the menus.
2. Use the ▲ or ▼ key to select *Projector control* and press **ENTER**.

- Use the ▲ or ▼ key to select *Serial communication* and press **ENTER**.

The serial communication menu opens.

- Use the ▲ or ▼ key to select *Interface standard* and press **ENTER** to toggle between [RS232] or [RS422].

Default: [RS232]

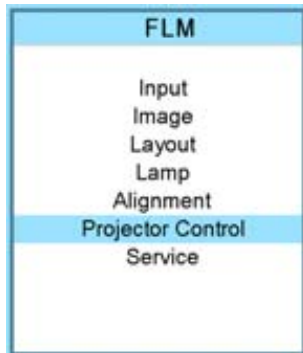

Image 13-12

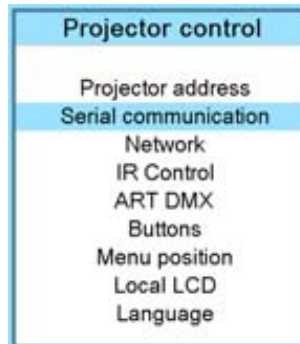

Image 13-13

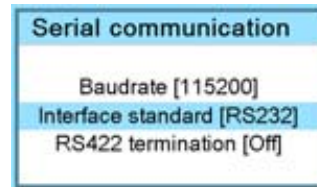

Image 13-14

### 13.3.3 RS422 termination

#### What can be done?

When the interface standard is set to RS422, the last projector in a line should be RS422 terminated (ON position). All others in the line should be in the OFF position.

#### How to set

- Press **MENU** to activate the menus.
- Use the ▲ or ▼ key to select *Projector control* and press **ENTER**.
- Use the ▲ or ▼ key to select *Serial communication* and press **ENTER**.

The serial communication menu opens.

- Use the ▲ or ▼ key to select *RS422 termination* and press **ENTER** to toggle between [On] or [Off].

Default: [On]

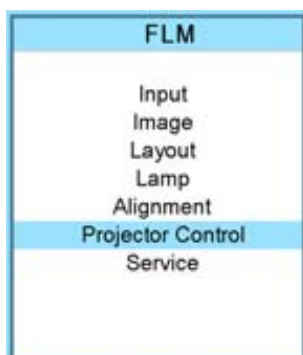

Image 13-15

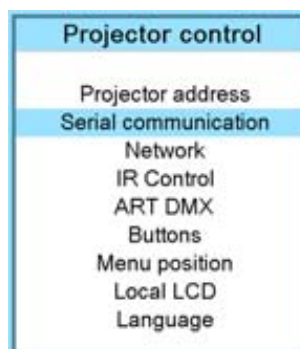

Image 13-16

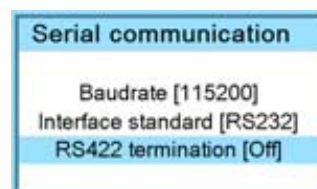

Image 13-17

## 13.4 Network

### Overview

- Introduction to a Network connection
- DHCP setup
- IP-address set up
- Subnet-mask set up
- Default Gateway set up

### 13.4.1 Introduction to a Network connection

---



#### DHCP

Dynamic host configuration protocol. DHCP is a communications protocol that lets network administrators manage centrally and automate the assignment of IP addresses in an organization's network. Using the Internet Protocol, each machine that can connect to the Internet needs a unique IP address. When an organization sets up its computer users with a connection to the Internet, an IP address must be assigned to each machine. Without DHCP, the IP address must be entered manually at each computer and, if computers move to another location in another part of the network, a new IP address must be entered. DHCP lets a network administrator supervise and distribute IP addresses from a central point and automatically sends a new IP address when a computer is plugged into a different place in the network.

---



#### IP

Internet Protocol. The network layer of TCP/IP. Required for communication with the internet.

---



#### Subnet mask

A number that is used to identify a subnetwork so that IP addresses can be shared on a local area network.

---



#### Default Gateway

A router that serves as an entry point into and exit point out of a network. For example, a local network (LAN) may need a gateway to connect it to a wide area network (WAN) or to the Internet.

---



#### MAC address

Media Access Control address. Unique hardware number, used in combination with the IP-address to connect to the network (LAN or WAN).

---

### What should be set up for an Ethernet address?

2 ways can be used to assign an address:

- use the DHCP setting so that an automatic address will be assigned.
- Assign manually an IP address, Net-mask (subnet-mask), (default) gateway address.
  - Set the IP-Address field to the desired value. This must NOT be 0.0.0.0 for static IP-Address assignment. The IP address identifies a projector's location on the network in the same way a street address identifies a house on a city block. Just as a street address must identify a unique residence, an IP address must be globally unique and have a uniform format.
  - Set the Subnet-Mask as appropriate for the local subnet.
  - Set the Default-Gateway to the IP-Address of the local router (MUST be on the local subnet!) on the same network as this projector that is used to forward traffic to destinations beyond the local network. This must not be 0.0.0.0. If there is no router on the projector's local subnet then just set this field to any IP-Address on the subnet.

### 13.4.2 DHCP setup

#### How to switch DHCP setting?

1. Press **MENU** to activate the menus.
2. Use the **▲** or **▼** key to select *Projector control* and press **ENTER**.
3. Use the **▲** or **▼** key to select *Ethernet* and press **ENTER**.

The Ethernet menu opens.

4. Use the **▲** or **▼** key to select *DHCP*.
5. Press **ENTER** to toggle the DHCP setting.

[ON] = DHCP is activated. Automatic assigning of an address is activated.

[OFF ] = DHCP is deactivated. A fixed address will be used.

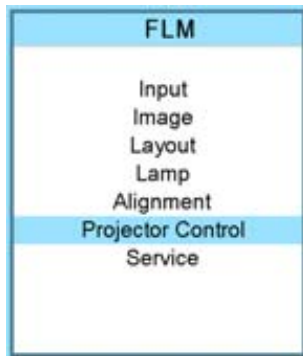

Image 13-18

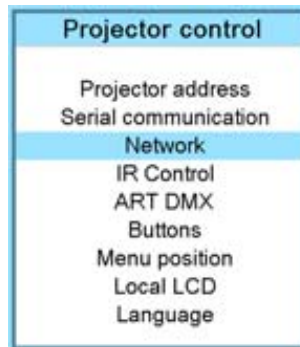

Image 13-19

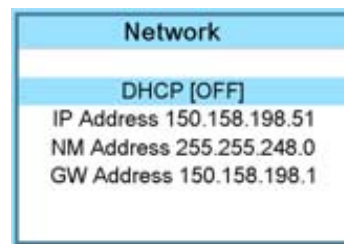

Image 13-20

### 13.4.3 IP-address set up

#### How to set up?

1. Press **MENU** to activate the menus.
2. Use the **▲** or **▼** key to select *Projector control* and press **ENTER**.
3. Use the **▲** or **▼** key to select *Network* and press **ENTER**.

The Network menu opens.

4. Use the **▲** or **▼** key to select *IP-address* and press **ENTER** to select.

**Note:** An address contains 4 octets with a maximum value of 255.

*This must NOT be 0.0.0.0 for static IP-Address assignment.*

5. Use the **▲** or **▼** key to select the desired digit and press **◀** or **▶** key to select the next digit in the address.  
Or,  
enter the value with the digit keys on the remote control or local keypad. The next digit in the address will be selected automatically.
6. Press **EXIT** to return.

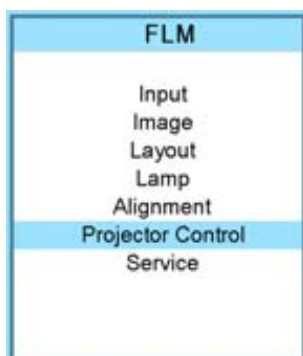

Image 13-21

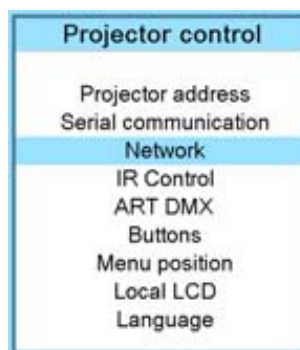

Image 13-22

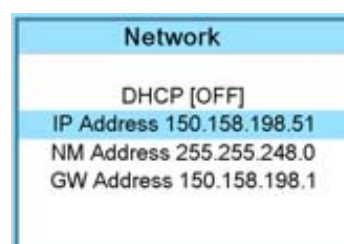

Image 13-23

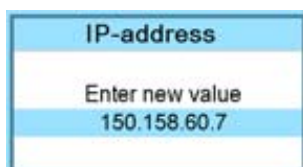

Image 13-24

### 13.4.4 Subnet-mask set up

#### How to set up?

1. Press **MENU** to activate the menus.

## 13. Projector control

- Use the ▲ or ▼ key to select *Projector control* and press **ENTER**.
- Use the ▲ or ▼ key to select *Network* and press **ENTER**.

The Ethernet menu opens.

- Use the ▲ or ▼ key to select *Subnet mask* and press **ENTER** to select.  
**Note:** An address contains 4 octets with a maximum value of 255.

Fill out the 4 fields as appropriate for the local subnet.

- Use the ▲ or ▼ key to select the desired digit and press ◀ or ▶ key to select the next digit in the address.  
Or,  
enter the value with the digit keys on the remote control or local keypad. The next digit in the address will be selected automatically.
- Press **EXIT** to return.

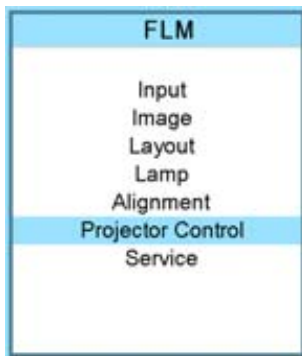

Image 13-25

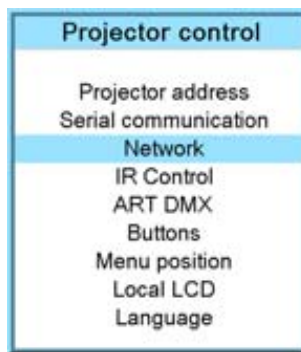

Image 13-26

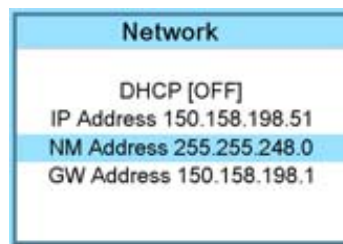

Image 13-27

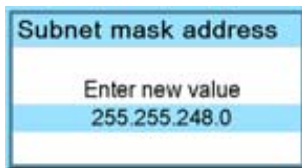

Image 13-28

### 13.4.5 Default Gateway set up

#### How to set up?

- Press **MENU** to activate the menus.
- Use the ▲ or ▼ key to select *Projector control* and press **ENTER**.
- Use the ▲ or ▼ key to select *Network* and press **ENTER**.

The Ethernet menu opens.

- Use the ▲ or ▼ key to select *Default Gateway* and press **ENTER** to select.  
**Note:** An address contains 4 octets with a maximum value of 255.

Set the default gateway to the IP-address of the router (MUST be on the local subnet!). If there is no router on the projector's local subnet then just set this field to any IP-address on the subnet.

- Use the ▲ or ▼ key to select the desired digit and press ◀ or ▶ key to select the next digit in the address.  
Or,  
enter the value with the digit keys on the remote control or local keypad. The next digit in the address will be selected automatically.  
**Note:** This must NOT be 0.0.0.0

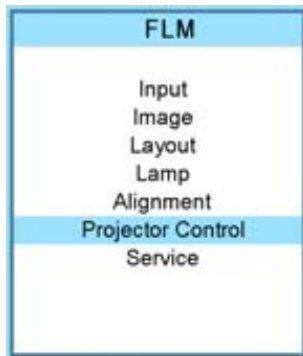

Image 13-29

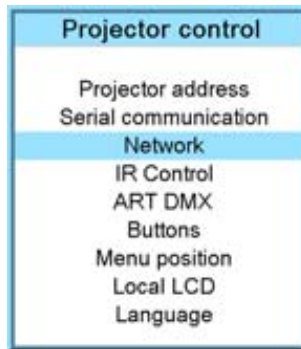

Image 13-30

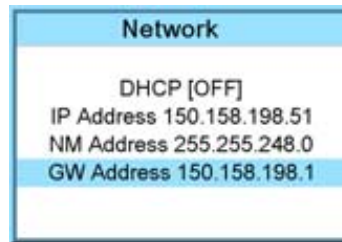

Image 13-31

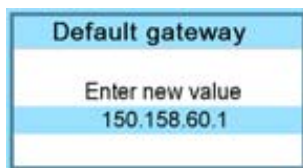

Image 13-32

6. Press **EXIT** to return.

## 13.5 IR control switching

### What can be done?

Each IR receiver inside the projector can be activated or deactivated. When an IR receiver is deactivated, no IR signal send to this IR receiver will be processed.

### How to switch

1. Press **MENU** to activate the menus.
2. Use the **▲** or **▼** key to select *Projector control* and press **ENTER**.
3. Use the **▲** or **▼** key to select *IR Control* and press **ENTER**.
4. Use the **▲** or **▼** key to select the desired IR receiver and press **ENTER** to toggle this receiver [on] or [off].

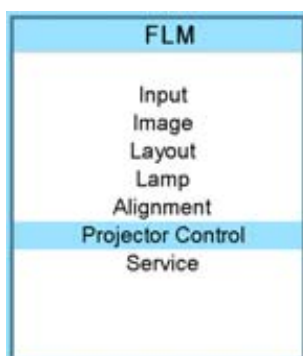

Image 13-33

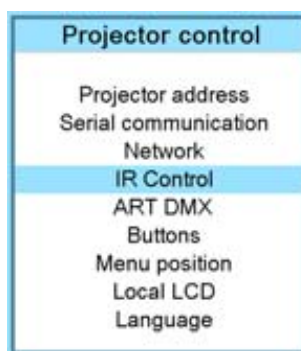

Image 13-34

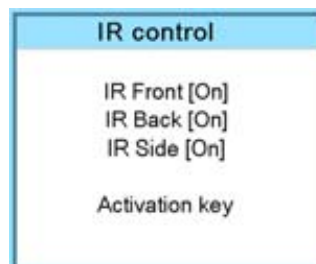

Image 13-35

## 13.6 Art-Net DMX



### DMX

DMX-512 Lighting protocol, here used over Ethernet. Carries information of 512 channels from a lighting controller to lighting devices. Standardized by USITT.



### Overview

- DMX address
- DMX universe
- DMX monitor
- DMX mode
- Art-Net activation
- Home lens at startup

### Art-Net DMX

When using a DMX console compatible with Art-Net, the Ethernet network serves as the link for DMX control.

Make sure that your lighting desk and all projectors are within the same IP address range. It can be necessary to set DHCP to [Off] for each projector and to enter an IP address manually which is in the IP address range of the lighting console.

#### 13.6.1 DMX address

##### What should be done ?

Before a projector can execute DMX commands, a unique address, called DMX address, should be given to the projector. This address can vary from 0 to 512.

##### How to set a DMX address

1. Press **MENU** to activate the menus.
2. Use the **▲** or **▼** key to select *Projector control* and press **ENTER**.
3. Use the **▲** or **▼** key to select *ART DMX* and press **ENTER**.
4. Use the **▲** or **▼** key to select *DMX address* and press **ENTER**.  
The edit DMX address window opens.
5. Use the **▲** or **▼** key to select a new value  
Or,  
enter a value with the digit keys on the remote control or local keypad.
6. Use the **◀** or **▶** key to select the next digit and repeat step 5.
7. When the desired address is entered, press **ENTER** to store that address.

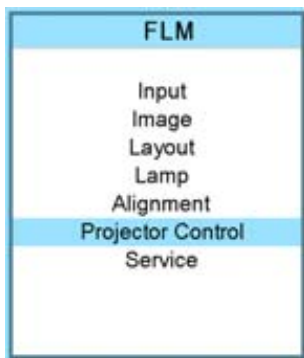

Image 13-36

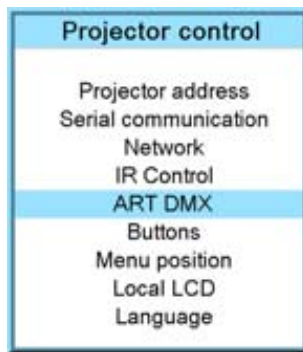

Image 13-37

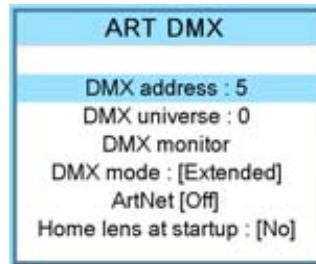

Image 13-38

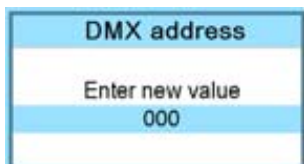

Image 13-39

#### 13.6.2 DMX universe

##### What can be done ?

Depending on the DMX mode, one DMX universe can contain a different number of projectors. E.g. DMX mode = basis, the DMX universe can contain up to 256 projectors



### How to set a DMX universe

1. Press **MENU** to activate the menus.
2. Use the ▲ or ▼ key to select *Projector control* and press **ENTER**.
3. Use the ▲ or ▼ key to select *ART DMX* and press **ENTER**.
4. Use the ▲ or ▼ key to select *DMX universe* and press **ENTER**.
5. Use the ▲ or ▼ key to select a new value  
Or,  
enter a value with the digit keys on the remote control or local keypad.
6. Use the ◀ or ▶ key to select the next digit and repeat step 5.
7. When the desired universe value is entered, press **ENTER** to store that value.

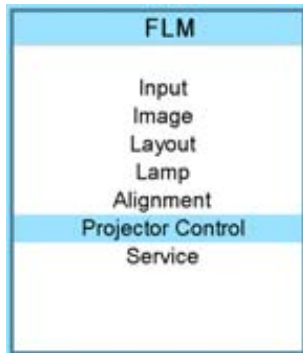

Image 13-40

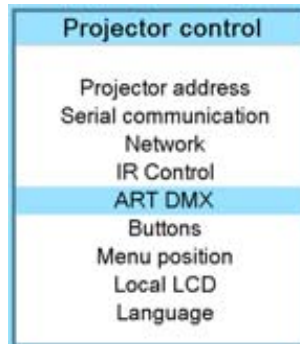

Image 13-41



Image 13-42

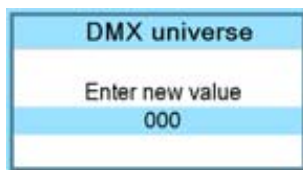

Image 13-43

### 13.6.3 DMX monitor

#### What can be done ?

If a DMX device is connected, the settings per channel can be displayed in an on screen menu.

#### How to start up the monitoring

1. Press **MENU** to activate the menus.
2. Use the ▲ or ▼ key to select *Projector control* and press **ENTER**.
3. Use the ▲ or ▼ key to select *ART DMX* and press **ENTER**.
4. Use the ▲ or ▼ key to select *DMX monitor* and press **ENTER**.

The *DMX monitor* window opens. Depending on the DMX mode, a different view of the DMX monitor window opens.

Example in dialog box is Extended mode

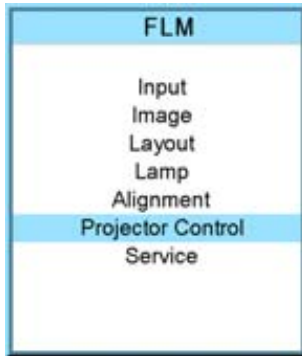

Image 13-44

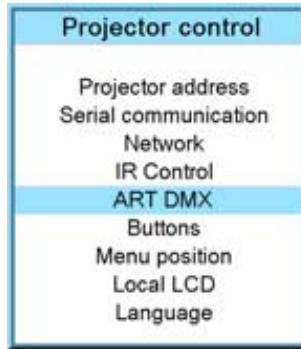

Image 13-45

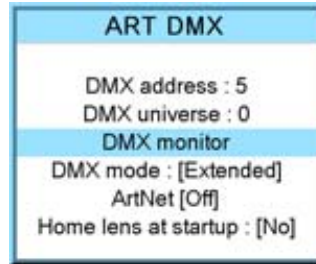

Image 13-46

| DMX Monitor |              |                                  |
|-------------|--------------|----------------------------------|
| Channel     | Function     | Parameter                        |
| 1           | Intensity    | 0 - 100%                         |
| 2           | Brightness   | 0 - 100%                         |
| 3           | Contrast     | 0 - 100%                         |
| 4           | Input select | Select between Input1 ,Input2... |
| 5           | Lens control | Shift up down, left ...          |
| 6           | Focus        | Coarse adjust                    |
| 7           | Focus        | Fine adjust                      |
| 8           | Zoom         | Coarse adjust                    |

Image 13-47



When selecting *DMX monitor* and no DMX device is connected, the message “*No DMX data, check connection <ENTER> to display channels*” appears on the screen. When ENTER is pressed the same window appears as DMX Monitor but without values.

### 13.6.4 DMX mode

#### What can be done ?

3 modes for DMX are available:

- Basic which has currently 2 channels implemented.
- Extended which has currently 10 channels implemented
- Full which has currently 9 channels implemented and 10th free channel.

Depending on the DMX application the correct mode has to be selected.

For the complete DMX chart of each mode, see "DMX chart", page 205.

#### How to set the mode

1. Press **MENU** to activate the menus.
2. Use the ▲ or ▼ key to select *Projector control* and press **ENTER**.
3. Use the ▲ or ▼ key to select *ART DMX* and press **ENTER**.
4. Use the ▲ or ▼ key to select *DMX mode* and press **ENTER** to toggle between [basic], [extended] or [full].

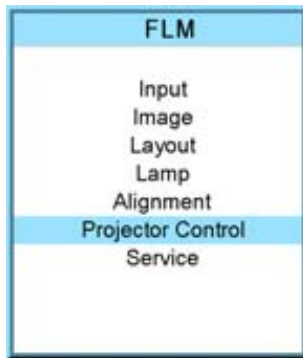

Image 13-48

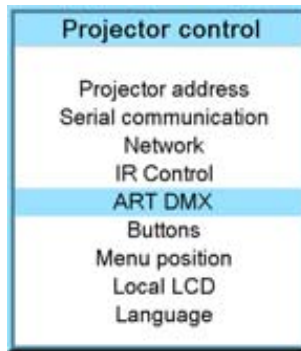

Image 13-49

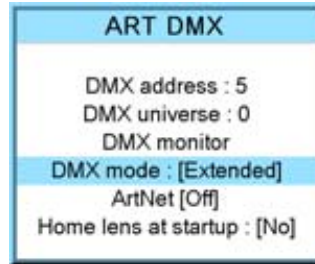

Image 13-50

### 13.6.5 Art-Net activation

#### What can be done ?

DMX via Art-Net can be activated [On] or blocked [Off].

Default value : off

#### How to toggle

1. Press **MENU** to activate the menus.
2. Use the ▲ or ▼ key to select *Projector control* and press **ENTER**.
3. Use the ▲ or ▼ key to select *ART DMX* and press **ENTER**.
4. Use the ▲ or ▼ key to select *ArtNet* and press **ENTER** to toggle between [Off] or [On].

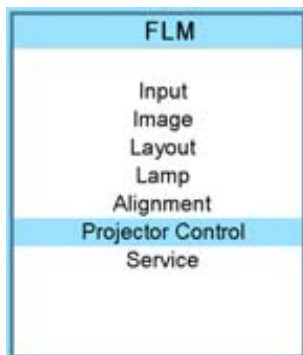

Image 13-51

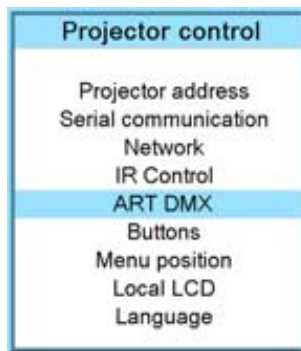

Image 13-52

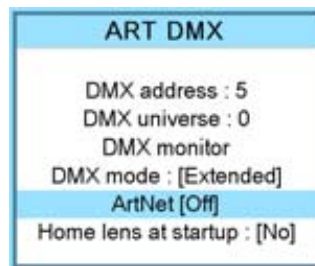

Image 13-53

### 13.6.6 Home lens at startup

#### What can be done ?

At power On the lens will search for its minimum and its maximum position. These minimum and maximum values will be used during this sessions to control the lens exactly. Once the lens limits are found, the lens returns to original position.

This full process takes about 3 to 4 minutes. During the homing cycle, all functions in the projector are blocked.

#### How to set

1. Press **MENU** to activate the menus.
2. Use the ▲ or ▼ key to select *Projector control* and press **ENTER**.
3. Use the ▲ or ▼ key to select *ART DMX* and press **ENTER**.
4. Use the ▲ or ▼ key to select *Home lens at startup* and press **ENTER** to toggle between [On] or [Off].

## 13. Projector control

[On] : home lens will be executed during power on.

[Off] : home lens will not be executed during power on.

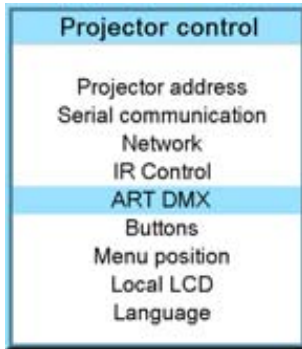

Image 13-54

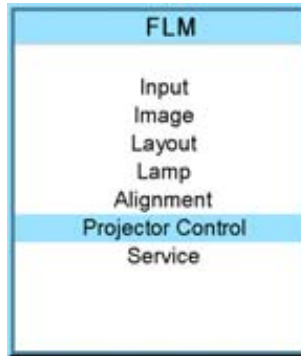

Image 13-55

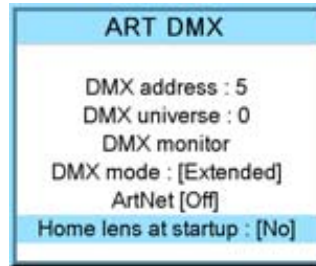

Image 13-56

## 13.7 Buttons

### Functionality

Some buttons on the RCU or local keypad can have a different functionality depending on the need of the projector owner.

### Overview

- Standby button
- APA (auto) button
- Shortcut keys

### 13.7.1 Standby button

#### What is possible?

When going to standby by pressing the standby button, the following can happen:

- Only the lamp will be switched off.
- The lamp and the power will be switched off.

#### How to set

1. Press **MENU** to activate the menus.
2. Use the **▲** or **▼** key to select *Projector control* and press **ENTER**.
3. Use the **▲** or **▼** key to select *Buttons* and press **ENTER**.
4. Use the **▲** or **▼** key to select *Standby* and press **ENTER** to toggle between *[Lamp on/off]* and *[Power up/down]*.

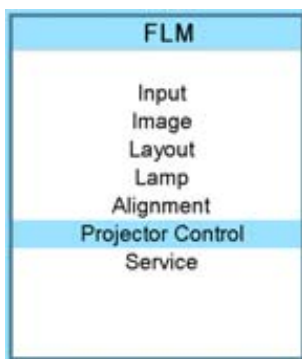

Image 13-57

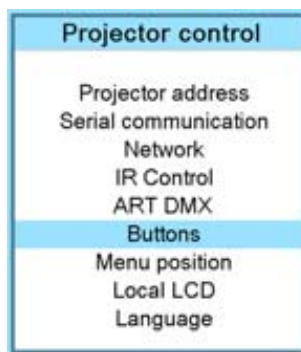

Image 13-58

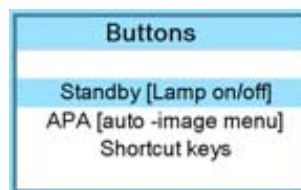

Image 13-59

### 13.7.2 APA (auto) button

#### What can be done?

The function of the APA (auto) button can be configured according to the wishes of the user.

The function can be:

- Align only (only aligning of the preview window is executed)
- Auto-image menu. This function opens an auto image menu where the user can make his choice between auto align, auto contrast/brightness and auto phase.

#### How to configure the APA (auto) button

1. Press **MENU** to activate the menus.
2. Use the **▲** or **▼** key to select *Projector control* and press **ENTER**.
3. Use the **▲** or **▼** key to select *Buttons* and press **ENTER**.
4. Use the **▲** or **▼** key to select *APA* and press **ENTER** to toggle between [*Align only*] and [*Auto-image menu*].

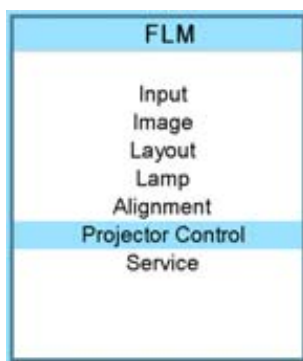

Image 13-60

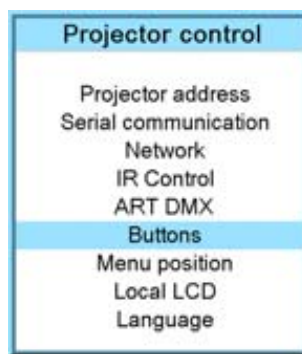

Image 13-61

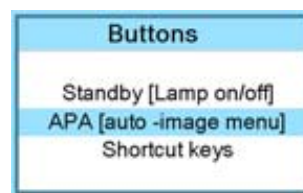

Image 13-62

### 13.7.3 Shortcut keys

#### What can be done?

An overview of the shortcut allocations with the corresponding menu is given. Those printed in bold are allocated.

The allocated shortcut keys can be cleared within this menu.

#### How to clear a shortcut key

1. Press **MENU** to activate the menus.
2. Use the **▲** or **▼** key to select *Projector control* and press **ENTER**.
3. Use the **▲** or **▼** key to select *Buttons* and press **ENTER**.
4. Use the **▲** or **▼** key to select *Shortcut keys* and press **ENTER**.
5. Use the **▲** or **▼** key to select a shortcut with allocation and press **ENTER** to remove the allocation.

The indication becomes *No allocation* and the key is free again for a new shortcut association.

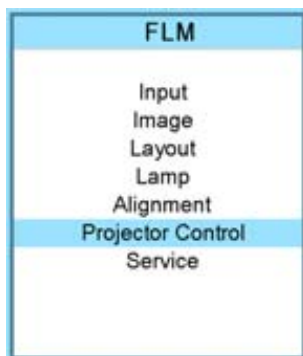

Image 13-63

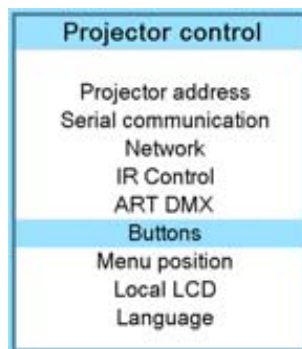

Image 13-64

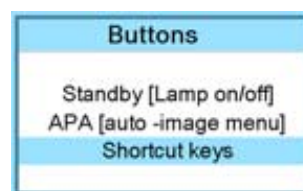

Image 13-65

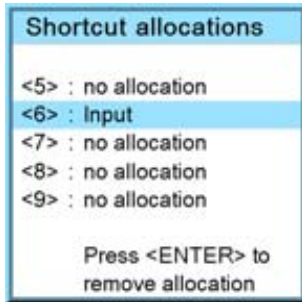

Image 13-66

## 13.8 Menu position

### Overview

- On screen menu
- Bar scale

### 13.8.1 On screen menu

#### What is possible?

The on screen menu can be positioned on 3 different places on the screen but always vertically centered on the screen.

The horizontal position can be:

- Centered
- Top aligned
- Bottom aligned

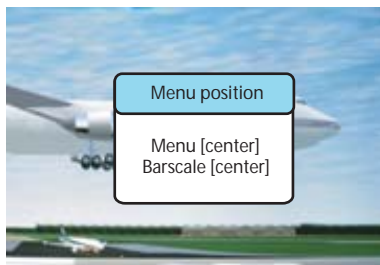
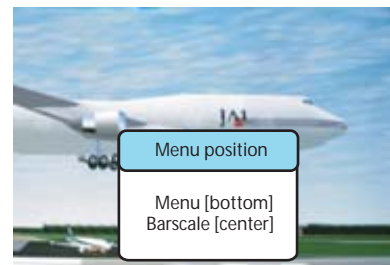
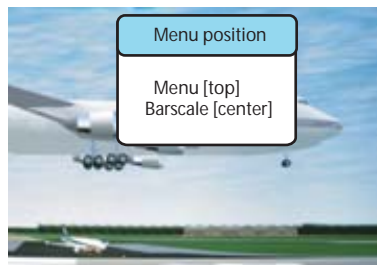

Image 13-67  
Menu position



#### How to change the position

1. Press **MENU** to activate the menus.
2. Use the **▲** or **▼** key to select *Projector control* and press **ENTER**.
3. Use the **▲** or **▼** key to select *Menu position* and press **ENTER**.
4. Use the **▲** or **▼** key to select *Menu* and press **ENTER** to toggle between *[Center]*, *[Top]* and *[Bottom]*.

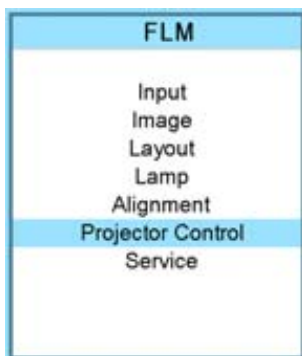

Image 13-68

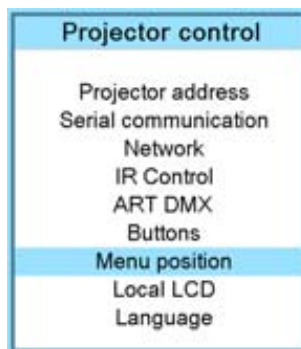

Image 13-69

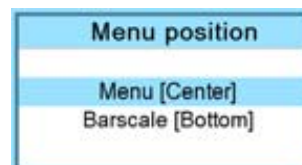

Image 13-70

## 13.8.2 Bar scale

### What is possible?

The bar scale can be positioned on 3 different places on the screen but always vertically on the right side.

The horizontal position can be:

- Centered
- Top aligned
- Bottom aligned



Image 13-71  
Bar scale position

### How to change the position

1. Press **MENU** to activate the menus.
2. Use the **▲** or **▼** key to select *Projector control* and press **ENTER**.
3. Use the **▲** or **▼** key to select *Menu position* and press **ENTER**.
4. Use the **▲** or **▼** key to select *Menu* and press **ENTER** to toggle between [*Center*], [*Top*] and [*Bottom*].

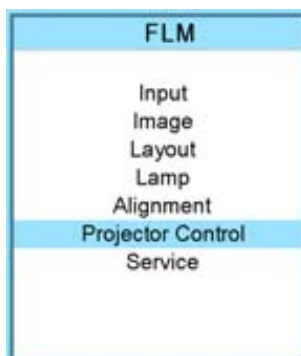

Image 13-72



Image 13-73

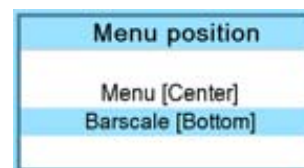

Image 13-74

## 13.9 Local LCD

### Overview

- Local LCD time out
- Local LCD contrast

### 13.9.1 Local LCD time out

#### What can be done ?

The backlight time of the local LCD after a command is given can be set.

#### How to change

1. Press **MENU** to activate the menus.
2. Use the **▲** or **▼** key to select *Projector control* and press **ENTER**.
3. Use the **▲** or **▼** key to select *Local LCD* and press **ENTER**.
4. Use the **▲** or **▼** key to select *Local LCD time out* and press **ENTER** to toggle between [Off], [5sec], [10sec] and [15sec].



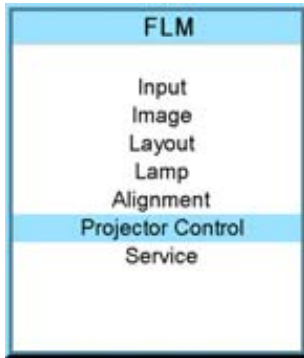

Image 13-75

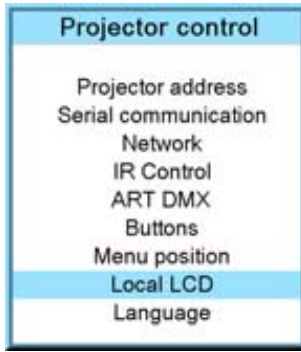

Image 13-76

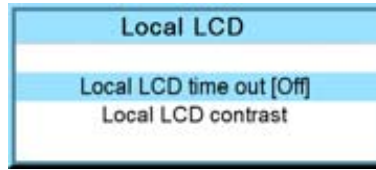

Image 13-77

### 13.9.2 Local LCD contrast

#### What is possible?

The contrast of the local LCD can be adapted the needs of the environment.

#### How to change?

1. Press **MENU** to activate the menus.
2. Use the **▲** or **▼** key to select *Projector control* and press **ENTER**.
3. Use the **▲** or **▼** key to select *Local LCD* and press **ENTER**.
4. Use the **▲** or **▼** key to select *Local LCD contrast* and press **ENTER**.
5. Use the **▲** or **▼** key to adjust the local contrast.

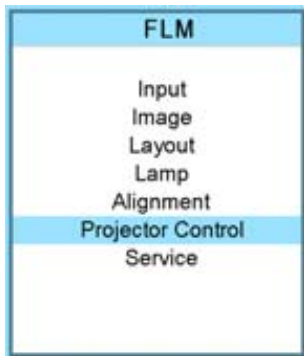

Image 13-78

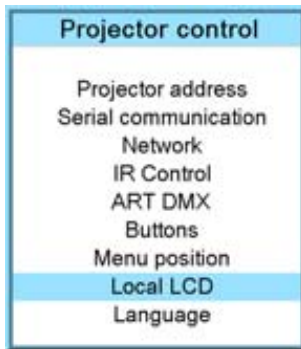

Image 13-79

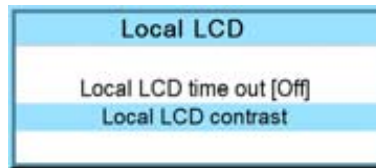

Image 13-80

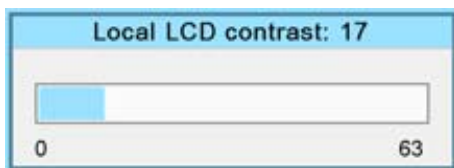

Image 13-81

### 13.10 Language selection

#### What can be done?

The user can change the language of the on screen menus and the local display menus to one of the available languages.



The following languages are available:

- English
- French
- German
- Spanish
- Italians

All available languages are indicated in the language of the country. The current active language is indicated by an asterisk (\*).

### How to change the language

1. Press **MENU** to activate the menus.
2. Use the **▲** or **▼** key to select *Projector control* and press **ENTER**.
3. Use the **▲** or **▼** key to select *Language* and press **ENTER**.
4. Use the **▲** or **▼** key to select the desired language. The change will take effect immediately.

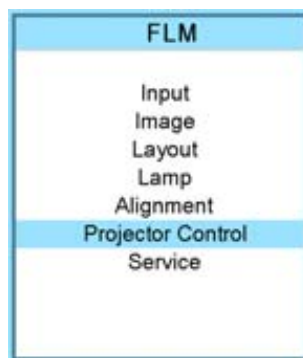

Image 13-82



Image 13-83



Image 13-84



# 14. SERVICE MENU

## About this chapter

This chapter refers to the Service menu in which the customer can find valuable information when calling the Barco help desk.

## 14.1 Overview flow

### Overview

| Level 1 | Level 2                   | Level 3  |
|---------|---------------------------|--|
| Service |                           |  |
|         | Identification            |  |
|         | Diagnosis                 | Version<br>Voltages<br>Temperatures<br>Fan speeds<br>I2C<br>SPI<br>Error logging |
|         | Convergence               |  |
|         | Internal service patterns | PNP IN<br>OSD<br>PMP OUT<br>FIB<br>Formatter                                     |
|         | Restore factory defaults  |  |
|         | Reset formatter           |  |
|         | Save custom settings      |  |
|         | Refill mode               |  |
|         | Broadcast mode            |  |
|         | USB memory                |  |

## 14.2 Identification

### What can be seen on the identification screen?

The identification screen shows the general information about the projector.

The following items will be displayed:

- Projector address
- Type of projector
- Package
- Configuration
- Baud rate
- IP address
- MAC address
- Text
- Serial number of projector: this number can be useful when calling for technical assistance.
- Runtime
- Lamp runtime
- Customer ID

### How to display the screen?

1. Press **MENU** to activate the menus.
2. Use the **▲** or **▼** key to select *Service* and press **ENTER**.  
The service window opens.
3. Use the **▲** or **▼** key to select *Identification* and press **ENTER**.  
The identification screen is displayed.

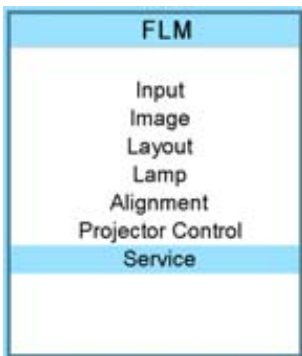

Image 14-1

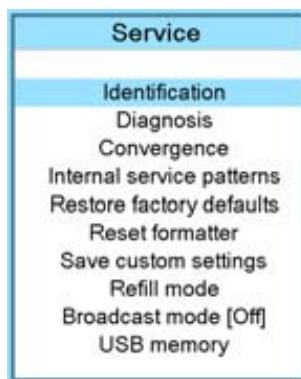

Image 14-2

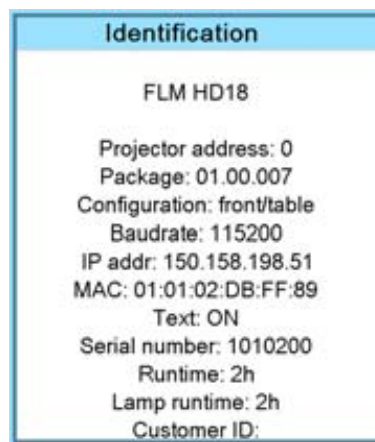

Image 14-3

### Add a customer ID to identification window

When on the identification window:

1. Use the **▲** or **▼** key to select *Customer ID* and press **ENTER**.  
The Customer ID input window opens.



Image 14-4

2. Use the **▲** or **▼** key to change the selected character.  
Use the **◀** or **▶** key to selected another character.

**Note:** *Digits can be entered with the digit keys on the remote control or on the local keypad. When a digit is entered in that way, the next character will be selected automatically.*

## 14.3 Diagnosis

### What can be seen?

The diagnosis menu gives the possibility to get an overview of the working of the projector.

### 14.3.1 How to start up the diagnosis?

#### Start up

1. Press **MENU** to activate the menus.
2. Use the **▲** or **▼** key to select *Service* and press **ENTER**.  
The service window opens.
3. Use the **▲** or **▼** key to select *Diagnosis* and press **ENTER**.  
The diagnosis screen will be displayed.

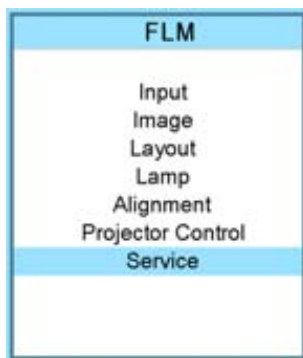

Image 14-5

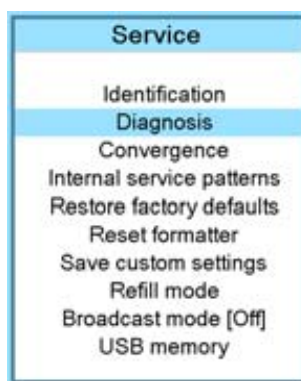

Image 14-6

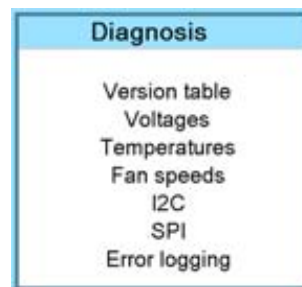

Image 14-7

Those menus who contain measured values, indicate also the limits if these are available.

### 14.3.2 Versions

#### How to display an overview?

1. Press **MENU** to activate the menus.
2. Use the **▲** or **▼** key to select *Service* and press **ENTER**.  
The service window opens.
3. Use the **▲** or **▼** key to select *Diagnosis* and press **ENTER**.  
The diagnosis screen is displayed.
4. Use the **▲** or **▼** key to select *Versions* and press **ENTER**.  
The Versions overview is displayed.

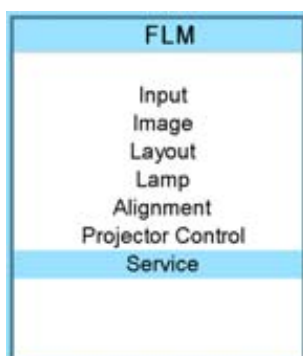

Image 14-8

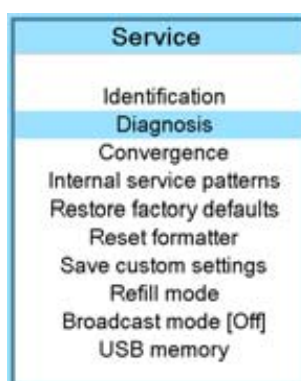

Image 14-9

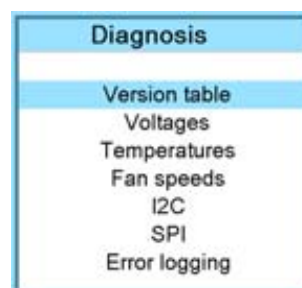

Image 14-10

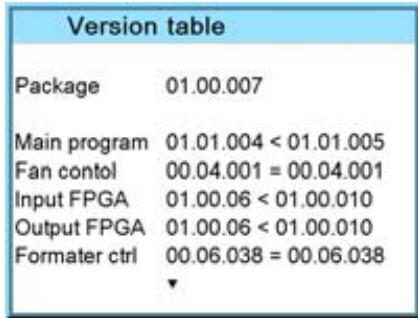

Image 14-11



Use the ▲ or ▼ item in the menu to select the previous or next page with information.

### 14.3.3 Voltages

#### How to display an overview?

1. Press **MENU** to activate the menus.
2. Use the ▲ or ▼ key to select *Service* and press **ENTER**.  
The service window opens.
3. Use the ▲ or ▼ key to select *Diagnosis* and press **ENTER**.  
The diagnosis screen will be displayed.
4. Use the ▲ or ▼ key to select *Voltages* and press **ENTER**.  
The Voltage overview menu will be displayed.

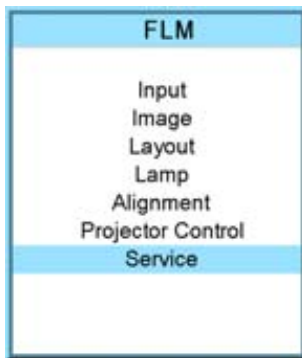

Image 14-12

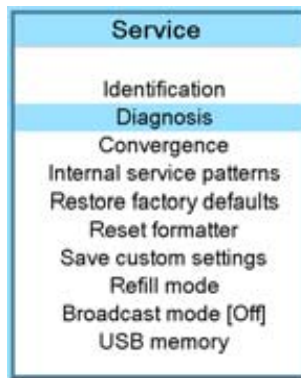

Image 14-13

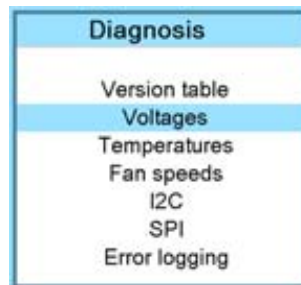

Image 14-14

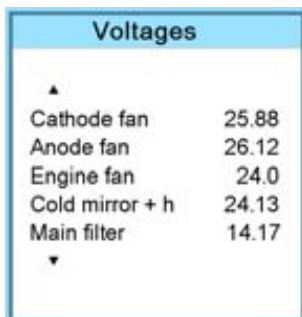

Image 14-15



Use the ▲ or ▼ item in the menu to select the previous or next page with information.

### 14.3.4 I<sup>2</sup>C diagnosis

#### How to select?

1. Press **MENU** to activate the menus.
2. Use the ▲ or ▼ key to select *Service* and press **ENTER**.  
The service window opens.
3. Use the ▲ or ▼ key to select *Diagnosis* and press **ENTER**.  
The diagnosis screen is displayed.
4. Use the ▲ or ▼ key to select *I2C* and press **ENTER**.  
The I<sup>2</sup>C diagnosis overview is displayed.

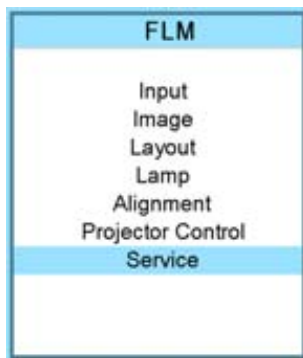

Image 14-16

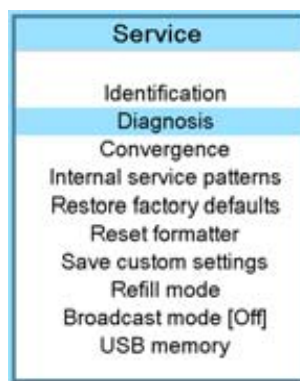

Image 14-17

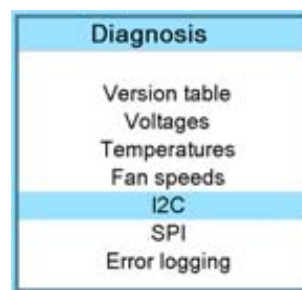

Image 14-18

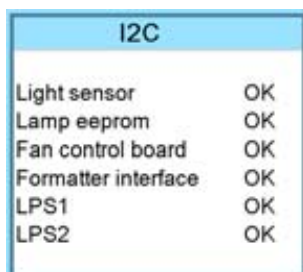

Image 14-19

### 14.3.5 Temperatures

#### How to get an overview?

1. Press **MENU** to activate the menus.
2. Use the ▲ or ▼ key to select *Service* and press **ENTER**.  
The service window opens.
3. Use the ▲ or ▼ key to select *Diagnosis* and press **ENTER**.  
The diagnosis screen will be displayed.
4. Use the ▲ or ▼ key to select *Temperatures* and press **ENTER**.

## 14. Service menu

---

The Temperature overview menu will be displayed.

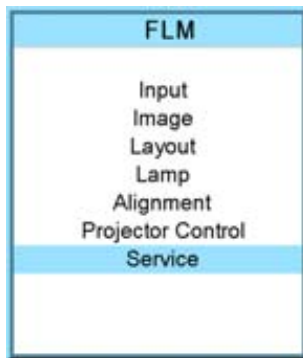

Image 14-20

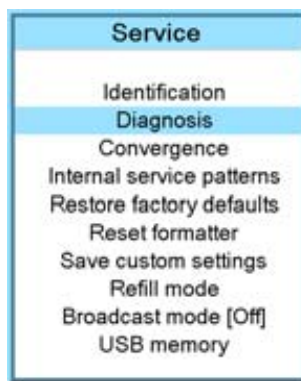

Image 14-21

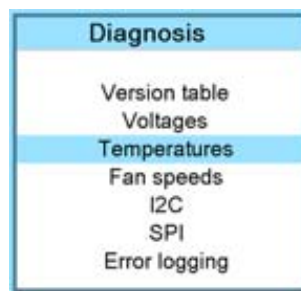

Image 14-22

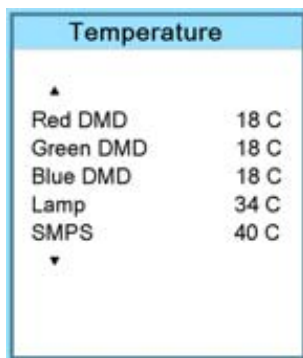

Image 14-23



Use the ▲ or ▼ item in the menu to select the previous or next page with information.

---

### 14.3.6 Fan speeds overview

#### How to get an overview?

1. Press **MENU** to activate the menus.
2. Use the ▲ or ▼ key to select *Service* and press **ENTER**.  
The service window opens.
3. Use the ▲ or ▼ key to select *Diagnosis* and press **ENTER**.  
The diagnosis screen will be displayed.
4. Use the ▲ or ▼ key to select *Fan speeds* and press **ENTER**.  
The Fan speeds overview menu will be displayed.



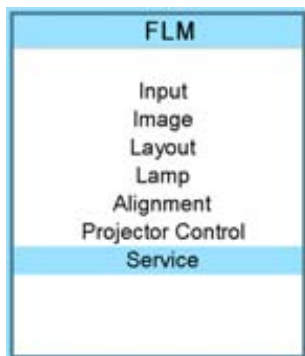

Image 14-24

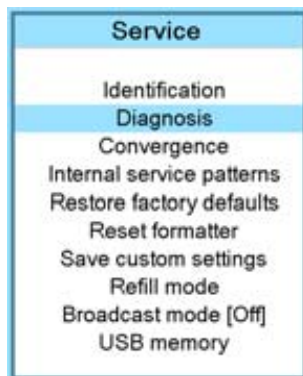

Image 14-25

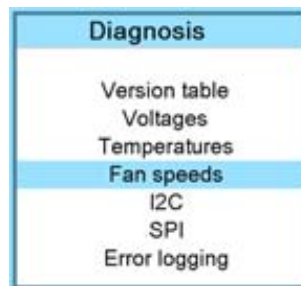

Image 14-26

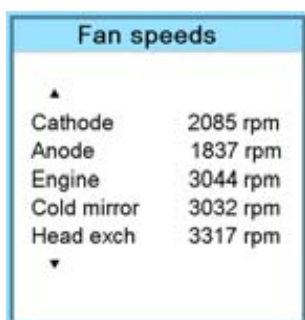

Image 14-27



Use the ▲ or ▼ item in the menu to select the previous or next page with information.

### 14.3.7 SPI

#### How to get an overview

1. Press **MENU** to activate the menus.
2. Use the ▲ or ▼ key to select *Service* and press **ENTER**.  
The service window opens.
3. Use the ▲ or ▼ key to select *Diagnosis* and press **ENTER**.  
The diagnosis screen will be displayed.
4. Use the ▲ or ▼ key to select *SPI* and press **ENTER**.  
The SPI overview menu will be displayed.

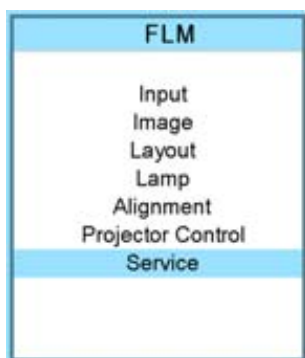

Image 14-28

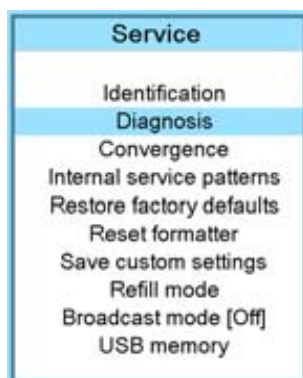

Image 14-29

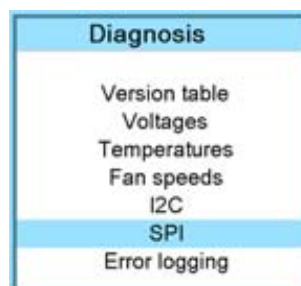

Image 14-30

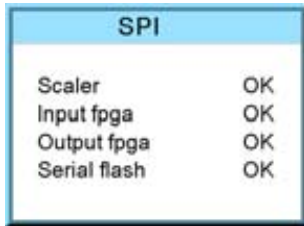

Image 14-31

### 14.3.8 Error logging overview

#### How to get an overview?

1. Press **MENU** to activate the menus.
2. Use the **▲** or **▼** key to select *Service* and press **ENTER**.  
The service window opens.
3. Use the **▲** or **▼** key to select *Diagnosis* and press **ENTER**.  
The diagnosis screen will be displayed.
4. Use the **▲** or **▼** key to select *Error logging* and press **ENTER**.  
The Error logging overview menu is displayed.

For more explanation about the stored error message, see chapter "21. Troubleshooting", "Error codes", page 211.

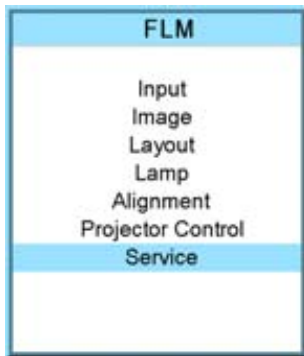

Image 14-32

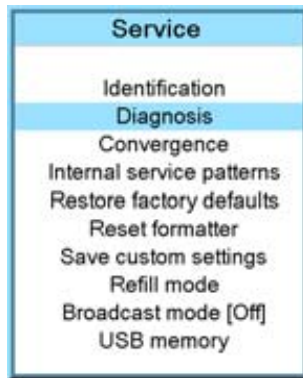

Image 14-33

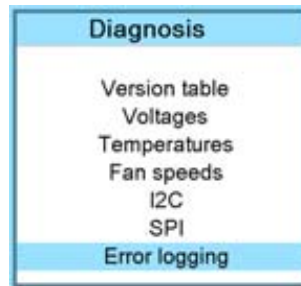

Image 14-34

## 14.4 Convergence

#### What can be done?

The convergence patterns can be used to check the convergence alignment of red, green and blue. If there is a misalignment of at least one 1 pixel, an electronic realignment is possible.

Mechanical realignment of the convergence can only be done by a qualified service technician.

#### How to display the convergence patterns and how to adjust

1. Press **MENU** to activate the menus.
2. Use the **▲** or **▼** key to select *Service* and press **ENTER**.  
The service window opens.
3. Use the **▲** or **▼** key to select *Convergence* and press **ENTER**.
4. Use the **▲** or **▼** key to select the desired pattern and press **ENTER**.

The convergence pattern is displayed. Press **ENTER** to toggle to another pattern. Press **EXIT** to return to the menu.

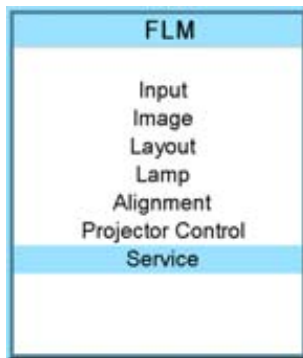

Image 14-35

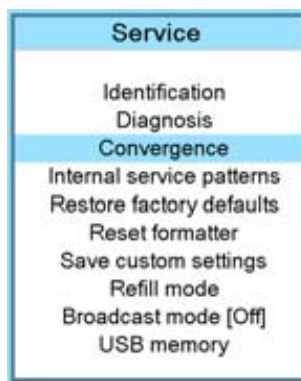

Image 14-36



Image 14-37

5. To adjust the convergence of the selected pattern, use the ◀ or ▶ for a horizontal adjustment and ▲ or ▼ for a vertical adjustment.

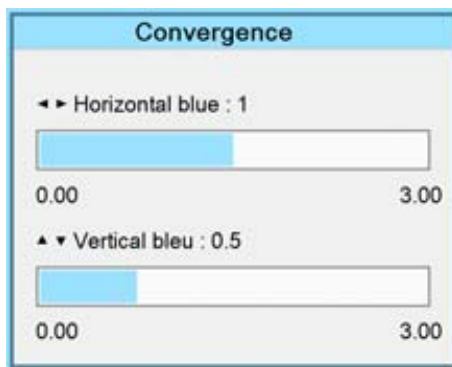

Image 14-38

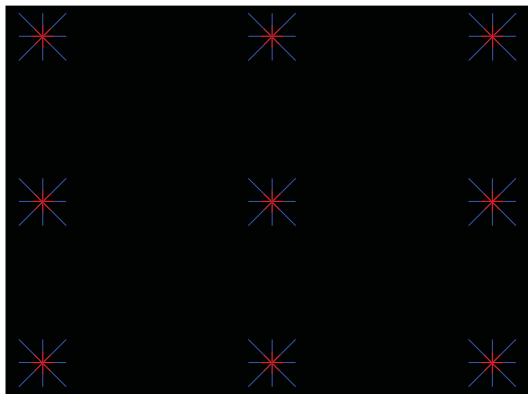
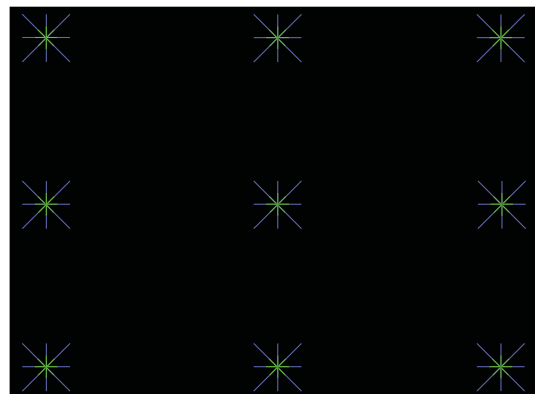

Image 14-39



Adjust until the crossing of the center Green (Red) convergence pattern coincide with the diagonal line of the center Blue convergence pattern.

## 14.5 Internal service patterns

### How to select

1. Press **MENU** to activate the menus.
2. Use the ▲ or ▼ key to select *Service* and press **ENTER**.  
The service window opens.
3. Use the ▲ or ▼ key to select *Internal service patterns* and press **ENTER**.

The internal service pattern window opens.

- Use the ▲ or ▼ key to select the desired patterns and press **ENTER**.

When a pattern is selected, press **ENTER** to toggle to other patterns of the selected type. Press **EXIT** to return to the internal service pattern menu.

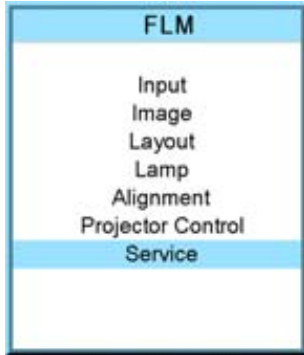

Image 14-40

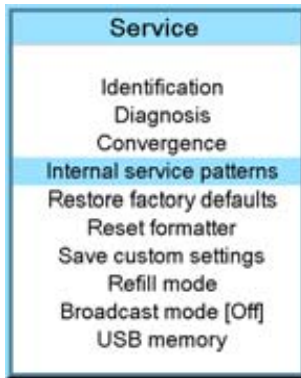

Image 14-41

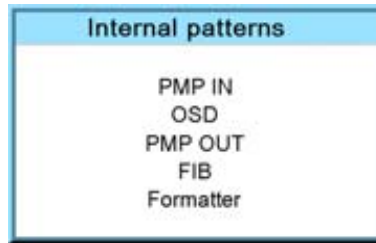

Image 14-42

## 14.6 Restore factory defaults

### What can be done?

All settings of the projector will be set to the original factory settings with the exception of :

- IP address
- Serial settings
- DMX settings
- Electronic convergence

For these settings the choice exists to exclude them in the reset operation. .

With this operation, all user settings with the exception of the above mentioned are erased.

### How to make an exception

- Press **MENU** to activate the menus.
- Use the ▲ or ▼ key to select *Service* and press **ENTER**.  
The service window opens.
- Use the ▲ or ▼ key to select *Restore factory defaults* and press **ENTER**.  
The factory defaults confirmation window opens.
- Use the ▲ or ▼ key to select the setting to exclude and press **ENTER** to toggle between [No] and [Yes].  
Repeat this step if necessary for the other settings.

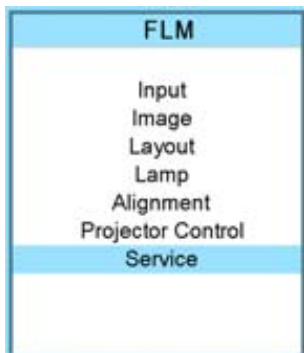

Image 14-43

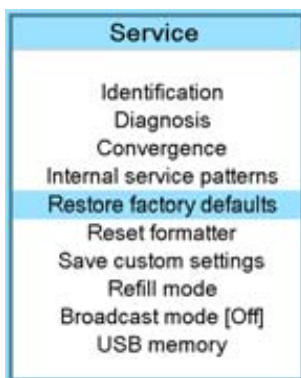

Image 14-44

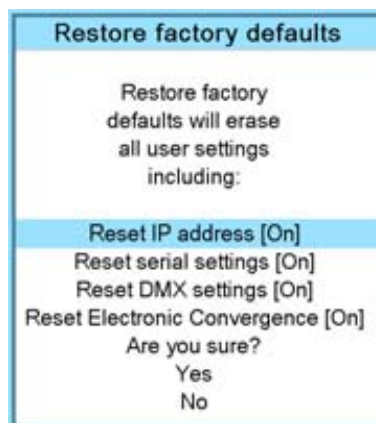

Image 14-45

### How to return to the default settings

1. Press **MENU** to activate the menus.
2. Use the **▲** or **▼** key to select *Service* and press **ENTER**.  
The service window opens.
3. Use the **▲** or **▼** key to select *Restore factory defaults* and press **ENTER**.  
The factory defaults confirmation window opens.
4. Use the **▲** or **▼** key to select *Yes* or *No* and press **ENTER**.  
If you are sure to restore the factory defaults and to erase the custom settings, select *Yes*.  
If you are not sure, select *No*.

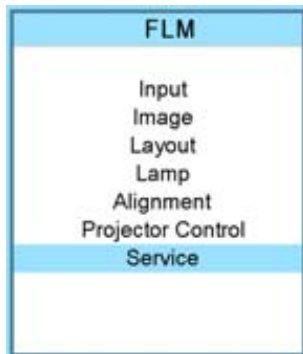

Image 14-46

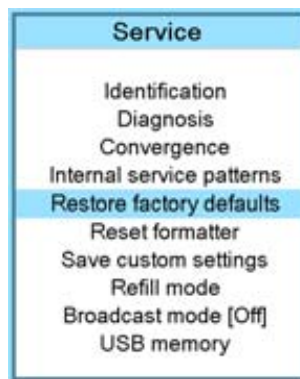

Image 14-47

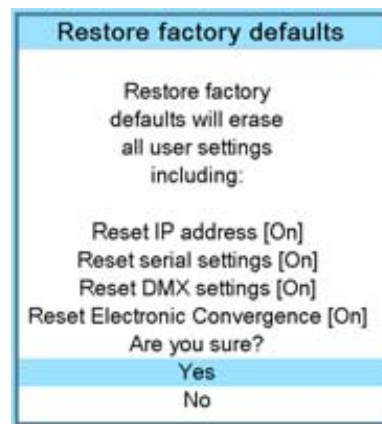

Image 14-48

## 14.7 Reset formatter

### How to reset

1. Press **MENU** to activate the menus.
2. Use the **▲** or **▼** key to select *Service* and press **ENTER**.  
The service window opens.
3. Use the **▲** or **▼** key to select *Reset formatter* and press **ENTER**.  
The formatter reset confirmation window opens.
4. Use the **▲** or **▼** key to select *Yes* or *No* and press **ENTER**.  
If you want to reset the formatter, select *Yes*.  
If you do not want to reset the formatter, select *No*.

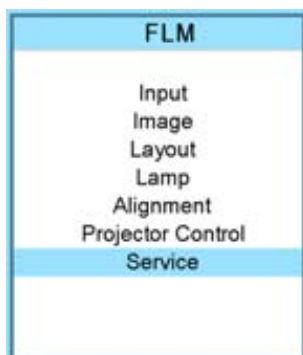

Image 14-49

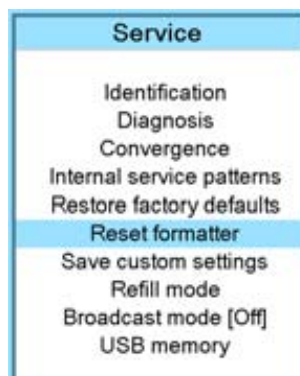

Image 14-50

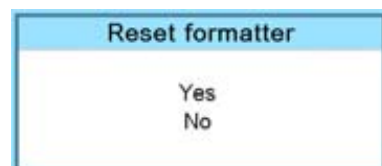

Image 14-51

---

## 14.8 Save custom settings

---

### What is done?

The current custom settings can be saved to the internal backup device in the same way as it would be done when the projector was switched to standby.

### How to save

1. Press **MENU** to activate the menus.
2. Use the **▲** or **▼** key to select *Service* and press **ENTER**.  
The service window opens.
3. Use the **▲** or **▼** key to select *Save custom settings* and press **ENTER**.

The custom settings are written to the internal backup device. A message menu "Save data ..." is displayed during the save operation.

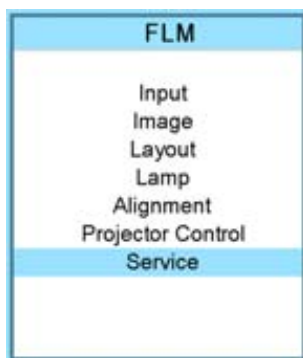

Image 14-52

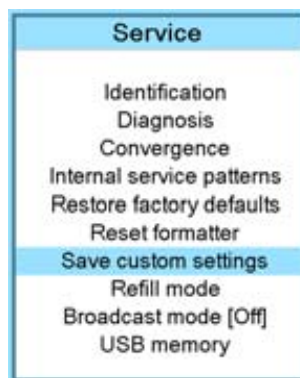

Image 14-53

---

## 14.9 Refill mode

---



Before selecting Refill mode, take first all preparations necessary to refill the cooling circuit.

### What can be done?

When all preparations are taken, the refill mode will automatically activate the refill process.

### How to start the refill mode

1. Press **MENU** to activate the menus.
2. Use the **▲** or **▼** key to select *Service* and press **ENTER**.  
The service window opens.
3. Use the **▲** or **▼** key to select *Refill mode* and press **ENTER**.  
A refill confirmation message is displayed.
4. Use the **▲** or **▼** key to select *Yes or No* and press **ENTER**.

Yes will switch the projector in refill mode.

When No is selected, the projector stays in normal mode.

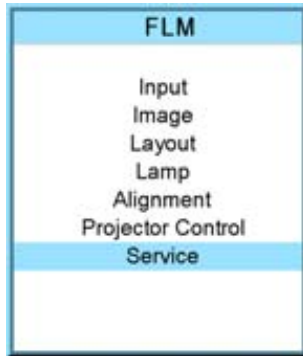

Image 14-54

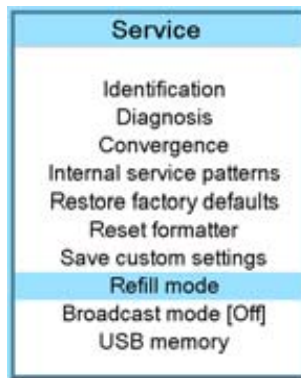

Image 14-55

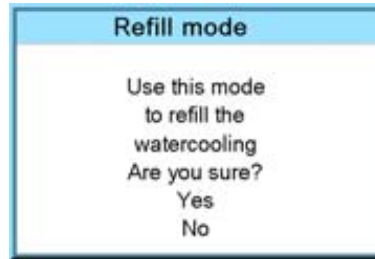

Image 14-56



**CAUTION:** Restart of the projector is necessary to terminate the refill mode. Before restarting, switch off the projector and reinstall first the cooling circuit.

## 14.10 Broadcast mode



Only accessible for HD projectors

### What can be done ?

"Broadcast mode" enables special sequences for the DMD's to support specific sources such as the Thompson Grass Valley World-cam. It shouldn't be used in any other circumstances as it would cause image flicker and dimmed images with normal sources.

Default position : [Off]

### How to set up

1. Press **MENU** to activate the menus.
2. Use the **▲** or **▼** key to select *Service* and press **ENTER**.  
The service window opens.
3. Use the **▲** or **▼** key to select *Broadcast mode* and press **ENTER** to toggle between [Off] and [On].

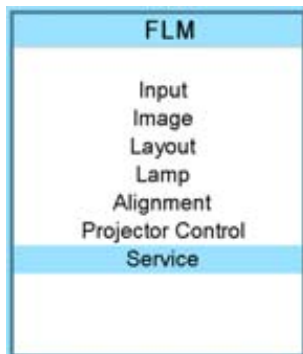

Image 14-57

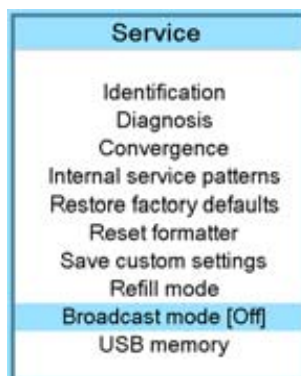

Image 14-58



**When Broadcast mode ON, switch also Genlock to ON (*Input* → *Input locking* → *Automatic + Options*) and enter the correct values for this source.**

---

## 14.11 USB memory

---

### What is possible with an USB device?

An USB device, FAT 16 formatted can be used, to save custom settings from the projector or to load custom settings to the projector. This function is very handy to clone projectors.

The following settings can be transported via an USB device:

- baudrate
- address
- common address
- orientation
- text on/off
- file load mode
- eco mode & dimming
- rs232 interface & rs232 termination
- no signal setup settings
- IR receiver settings
- native resolution
- min delay
- current language of on screen menus
- customer id
- Network settings (DHCP, IP address, net mask, gateway address)
- blanking & keystone
- ScenergiX
- gamma
- color standard
- source switching
- effect settings
- broadcast mode
- menu position
- button settings
- locking settings

### Saving custom settings

1. Connect a FAT 16 formatted USB device to the USB port.
2. Press **MENU** to activate the menus.
3. Use the **▲** or **▼** key to select *Service* and press **ENTER**.  
The service window opens.
4. Use the **▲** or **▼** key to select *USB memory* and press **ENTER**.
5. Use the **▲** or **▼** key to select *Save custom settings* and press **ENTER**.



The custom settings on the projector are stored on the USB device together with the serial number of the projector. Different saves can be made from different projectors on the same USB device.

When there is no USB device connected to the USB slot, a message, *No USB device found*, is displayed.

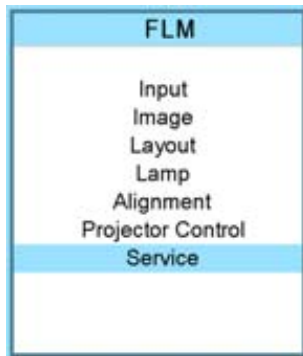

Image 14-59

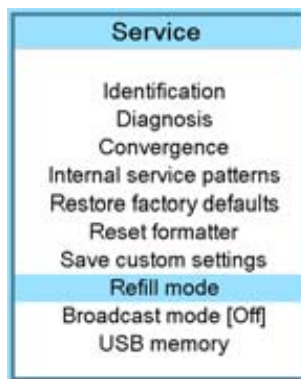

Image 14-60

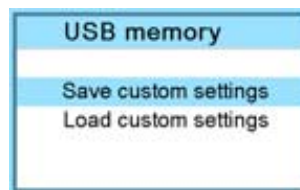

Image 14-61

### Load custom settings

1. Connect a FAT 16 formatted USB device to the USB port.
2. Press **MENU** to activate the menus.
3. Use the **▲** or **▼** key to select *Service* and press **ENTER**.

The service window opens.

4. Use the **▲** or **▼** key to select *USB memory* and press **ENTER**.
5. Use the **▲** or **▼** key to select *Load custom settings* and press **ENTER**.

An list of serial numbers is given.

6. Use the **▲** or **▼** key to select the serial number to start from to load the settings.

The settings from the selected projector on the USB device are loaded into the current attached projector. The current projector settings are overwritten with these settings.

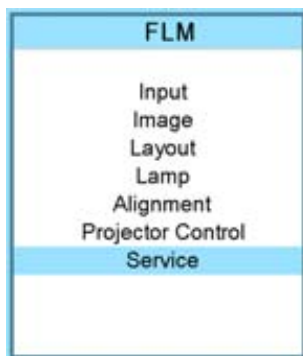

Image 14-62

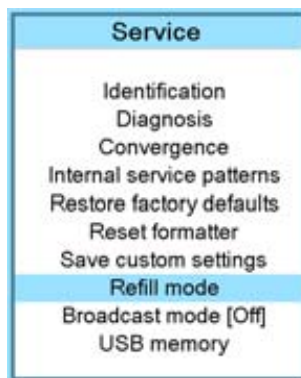

Image 14-63

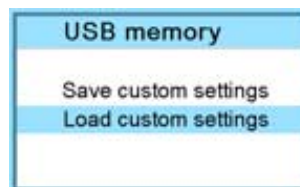

Image 14-64

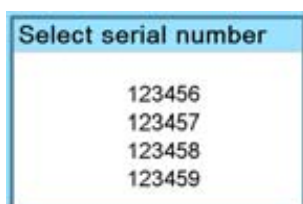

Image 14-65



# 15. MAINTENANCE

## About this chapter

This chapter contains detailed maintenance procedures like dust filter replacement, lens cleaning etc. These procedures can easily be performed by the operator of the projector.



**CAUTION:** All HEPA filters of the projector must be replaced on a regular basis, depending on the environment conditions of the projector.



**CAUTION:** The pressure of the Liquid Cooling Circuit should be checked regularly. This pressure, indicated on the internal manometer, should be between 0,5 and 1 bar. If not, corrective action should be taken by qualified technical service personnel.



**HEPA**  
High Efficiency Particulate Absorbing

## Overview

- Replacement of the dust filter on the front side
- Replacement of the dust filter on the bottom side
- Replacement of the dust filter on the top side
- Pressure verification of the liquid cooling circuit
- Cleaning the lens
- Cleaning the exterior of the projector

## 15.1 Replacement of the dust filter on the front side

### Necessary parts

New HEPA dust filter for the front side (R9854470).

### How to replace the HEPA dust filter on the front side of the projector ?

1. Remove the front cover of the projector, see "Removal of the front cover", page 191.
2. Remove the HEPA dust filter on the front side by pulling the two spring clamps away from the filter and then moving the filter forwards.

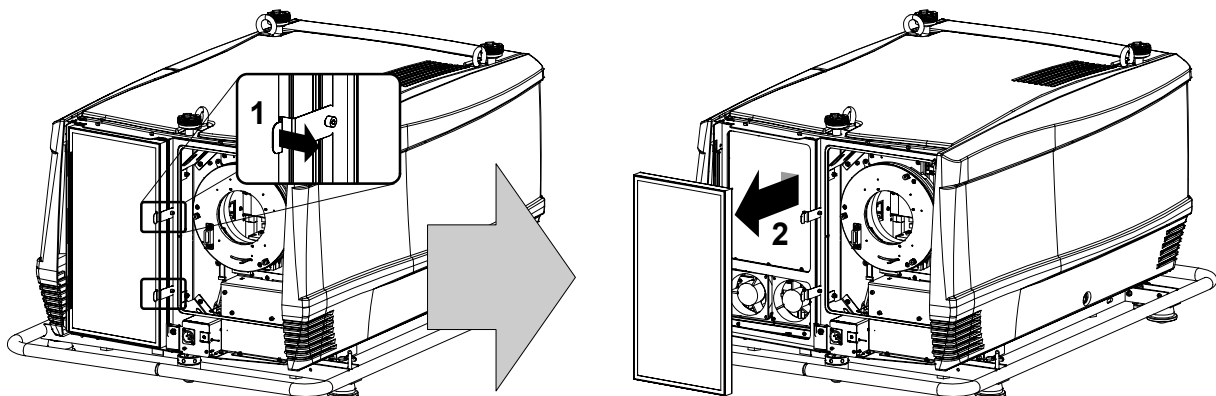

Image 15-1

3. Insert a new HEPA<sup>1</sup> filter by pulling the two spring clamps away and move the filter into position.  
**Caution:** Make sure that the airflow indicated on the dust filter match with the airflow of the fans.
4. Reinstall the front cover of the projector, see "Installation of the front cover", page 194.

1. High Efficiency Particulate Arrestant



**CAUTION:** Never install a used HEPA filter. Always install a new HEPA filter.

## 15.2 Replacement of the dust filter on the bottom side

### Necessary parts

- New HEPA dust filter for the bottom side (R9854480).
- 2.5 mm Allen key.

### How to replace the HEPA dust filter on the bottom side of the projector ?

1. Remove the side cover of the projector, see "Removal of the side cover", page 192.
2. Release (not remove) the two wedge lock screws (A) using a 2.5 mm Allen key as illustrated.

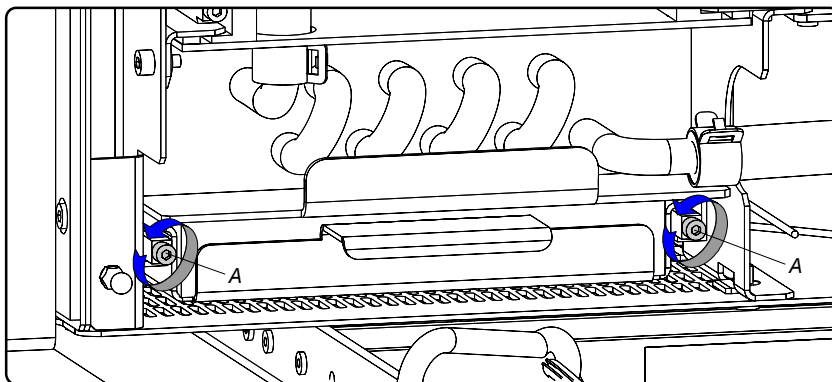

Image 15-2

3. Remove the filter (F) on the bottom side by pulling out the filter holder (H) as illustrated.

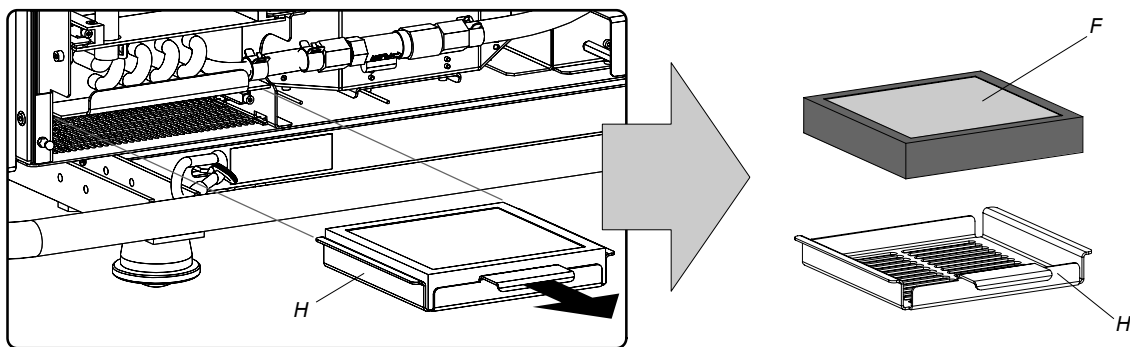

Image 15-3

4. Place a new HEPA dust filter in the filter holder.  
**Caution:** Make sure that the airflow indicated on the dust filter match with the airflow of the fans.
5. Reinstall the filter holder containing the new HEPA filter.
6. Fasten the two wedge lock screws (A) using a 2.5 mm Allen key as illustrated.

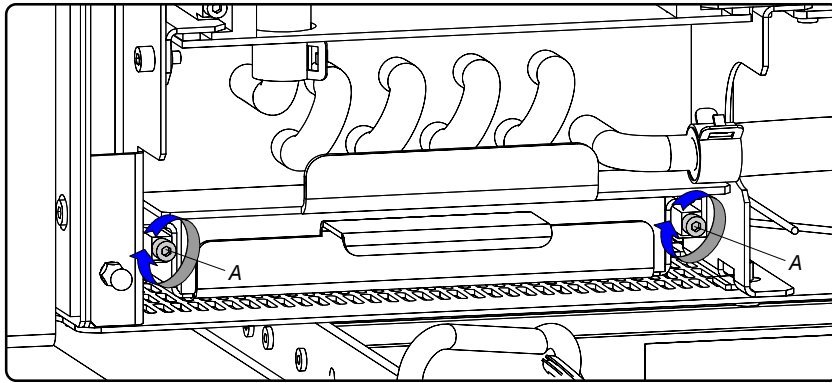

Image 15-4

7. Reinstall the side cover of the projector, see "Installation of the side cover", page 195.



**CAUTION:** Never install a used HEPA filter. Always install a new HEPA filter.

### 15.3 Replacement of the dust filter on the top side

#### Necessary parts

New HEPA dust filter for the top side (R9854480).

#### How to replace the HEPA dust filter on the top side of the projector ?

1. Remove the side cover of the projector, see "Removal of the side cover", page 192.
2. Remove the filter (F) on the top side by pulling out the filter holder (H) as illustrated.

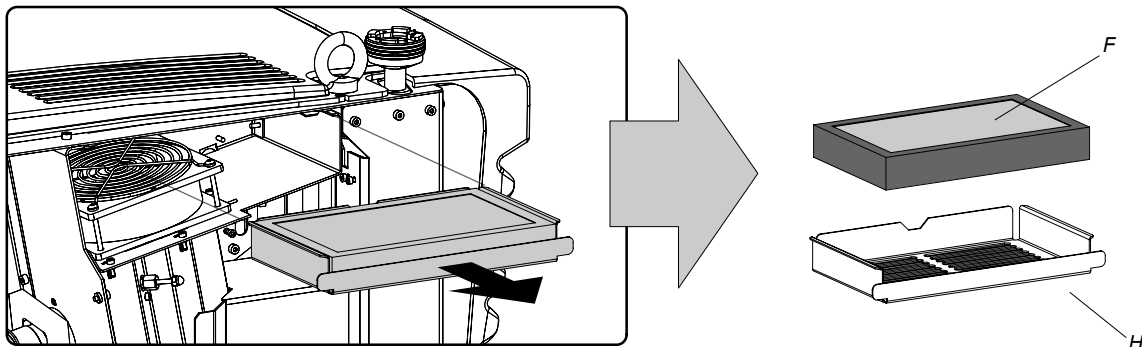

Image 15-5

3. Place a new HEPA dust filter in the filter holder.  
**Caution:** Make sure that the airflow indicated on the dust filter match with the airflow of the fans.
4. Reinstall the filter holder containing the new HEPA filter.
5. Reinstall the side cover of the projector, see "Installation of the side cover", page 195.



**CAUTION:** Never install a used HEPA filter. Always install a new HEPA filter.

### 15.4 Pressure verification of the liquid cooling circuit

#### How to check the pressure of the liquid cooling circuit inside the projector ?

1. Remove the side cover of the projector, see "Removal of the side cover", page 192.

2. Check the pressure indicated on the internal manometer of the liquid cooling circuit.

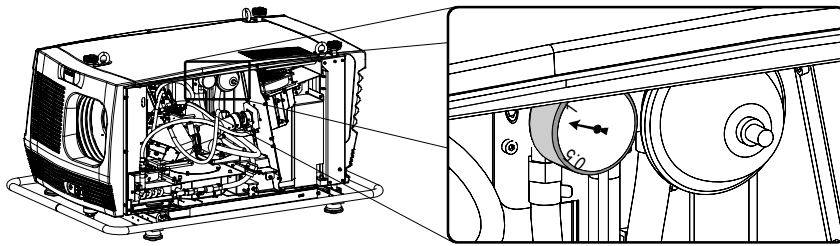

Image 15-6

3. This pressure should be between 0,5 and 1 bar. If the pressure, indicated on the manometer, is out of range, inform the responsible and qualified technicians, so they may take necessary corrective action.
4. Reinstall the side cover of the projector, see "Installation of the side cover", page 195.

## 15.5 Cleaning the lens

---



To minimize the possibility of damage to optical coatings, or scratches to lens surfaces, we have developed recommendations for cleaning. **FIRST**, we recommend you try to remove any material from the lens by blowing it off with clean, dry deionized air. **DO NOT** use any liquid to clean the lenses.

---

### Necessary tools

Toraysee™ cloth (delivered together with the lens kit). Order number : R379058.

### How to clean the lens ?

1. Always wipe lenses with a CLEAN Toraysee™ cloth.
2. Wipe lenses in a one single direction.  
**Warning:** Do not wipe back and forwards across the lens surface as this tends to grind dirt into the coating.
3. Do not leave the cleaning cloth in either an open room or lab coat pocket, as doing so can contaminate the cloth.
4. If smears occur when cleaning lenses, replace the cloth. Smears are the first indication of a dirty cloth.



**CAUTION:** Do not use fabric softener when washing the cleaning cloth or softener sheets when drying the cloth.

Do not use liquid cleaners on the cloth as doing so will contaminate the cloth.

---



Other lenses can also be cleaned safely with this Toraysee™ cloth.

---

## 15.6 Cleaning the exterior of the projector

---

### How to clean the exterior of the projector ?

1. Switch off the projector and unplug the power cord at the projector side.
2. Clean the housing of the projector with a damp cloth. Stubborn stains may be removed with a cloth lightly dampened with a mild detergent solution.

## 16. SERVICING

### About this chapter

This chapter contains general servicing procedures like lamp replacement, input unit replacement etc. Note that some of these procedures may only be performed by qualified technical service personnel.

### Overview

- Removal of the lamp house
- Removal of the input & communication unit
- Removal of an input module
- Installation of the lamp house
- Installation of the input & communication unit
- Installation of an input module
- Realignment of the lamp in its reflector

### Extra service information

Extra service information for qualified service technicians can be found on Barco's Partnerzone (URL:[www.partnerzone.events.barco.com](http://www.partnerzone.events.barco.com)). Registration is necessary.

If you are not yet registered, click on Partnerzone registration and follow the instructions. With the created login and password, it is possible to enter the partnerzone where you can find extra service information about the projector.

### 16.1 Removal of the lamp house



**WARNING:** This procedure may only be performed by qualified technical service personnel.



**CAUTION:** Never attempt to disassemble the lamp from its housing or to dispose of it. Return it to Barco. Due to its high internal pressure, the lamp may explode in either hot or cold states if improperly handled.

#### Necessary tools

7 mm flat screw driver.

#### How to remove the lamp house of the projector ?

1. Switch off the projector and unplug the power cord at the projector side.
2. Remove the lamp cover, see "Removal of the lamp cover", page 193.
3. Release the three spring lock screws of the lamp house as illustrated.

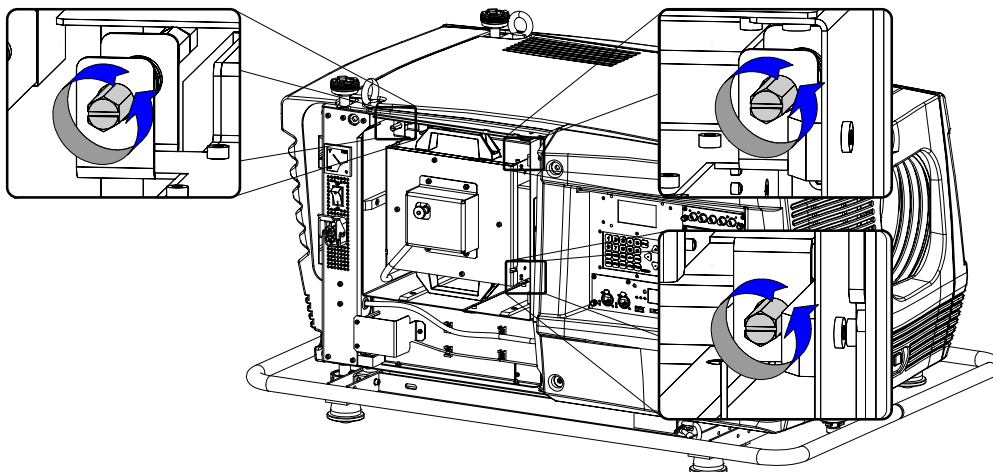

Image 16-1

4. Clasp the lamp house by the handles and pull the lamp house out of the projector.

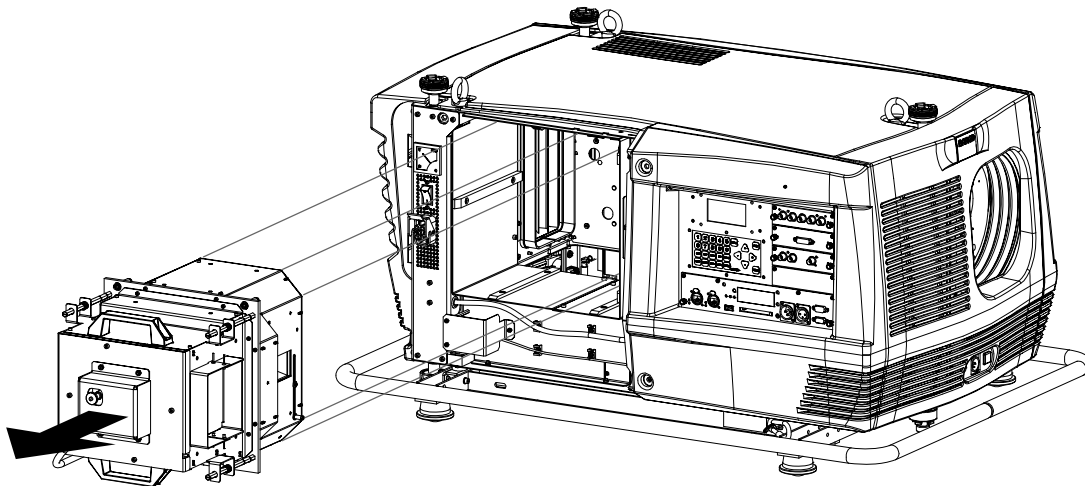

Image 16-2



While starting up the projector, the electronics detect if a lamp is installed. If no lamp is installed, it is not possible to start up the projector.

## 16.2 Removal of the input & communication unit



**WARNING:** This procedure may only be performed by qualified technical service personnel.

### Necessary tools

7 mm flat screw driver.

### How to remove the input & communication unit from the projector ?

1. Switch off the projector and unplug the power cord at the projector side. See procedure "Switching off", page 47.
2. Ensure that no cables are connected to one of the ports of the input & communication unit.
3. Remove the input cover, see "Removal of the input cover", page 193.
4. Release the four captive screws in the corners of the input and communication unit as illustrated.

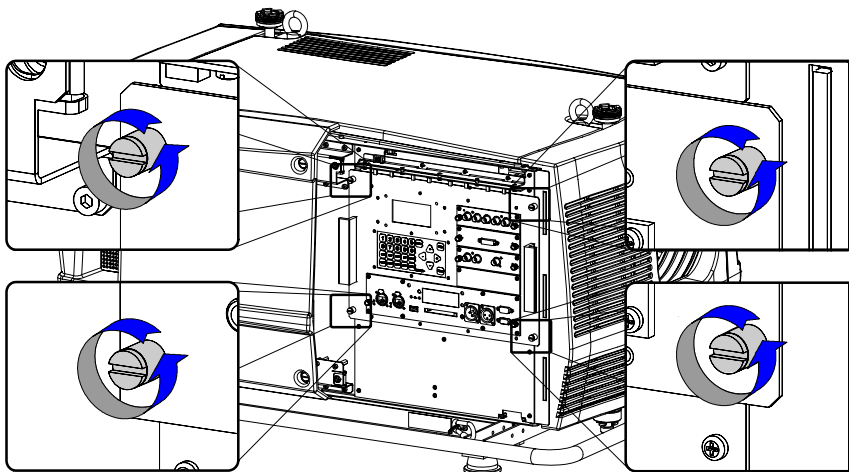

Image 16-3

5. Pull the input & communication unit out of its compartment, using the side handles provided.



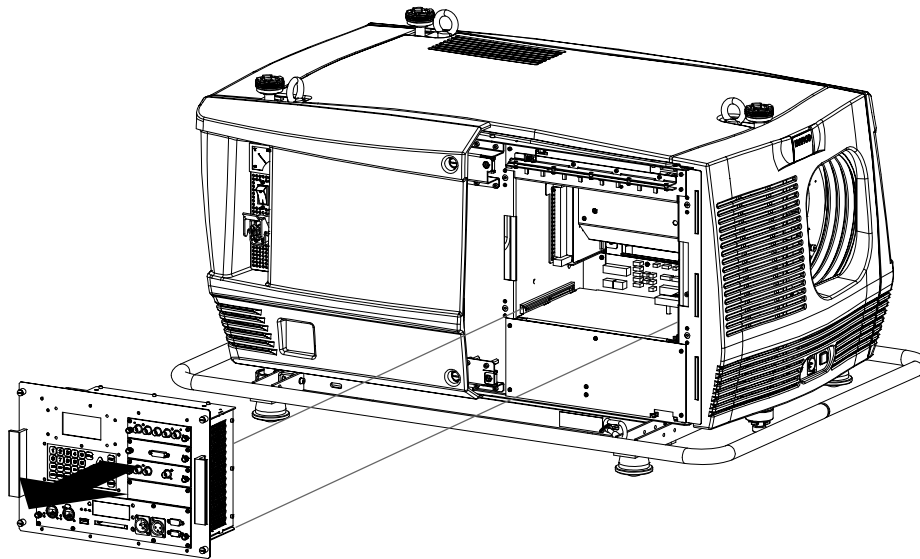

Image 16-4

### 16.3 Removal of an input module



The procedure below is applicable to all input modules of the input & communication unit of the projector.

#### Necessary tools

Phillips screw driver PH1.

#### How to remove an input module out of the input & communication unit of the projector ?

1. Switch off the projector and unplug the power cord at the projector side.
2. Release the two captive screws of the input module using a Phillips screw driver PH1.

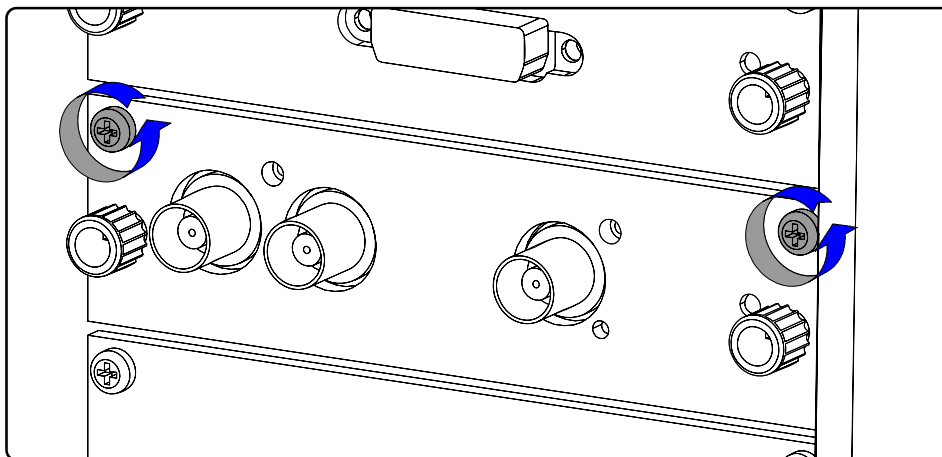

Image 16-5

3. Pull the input module out of the input & communication unit, via the two knobs provided.

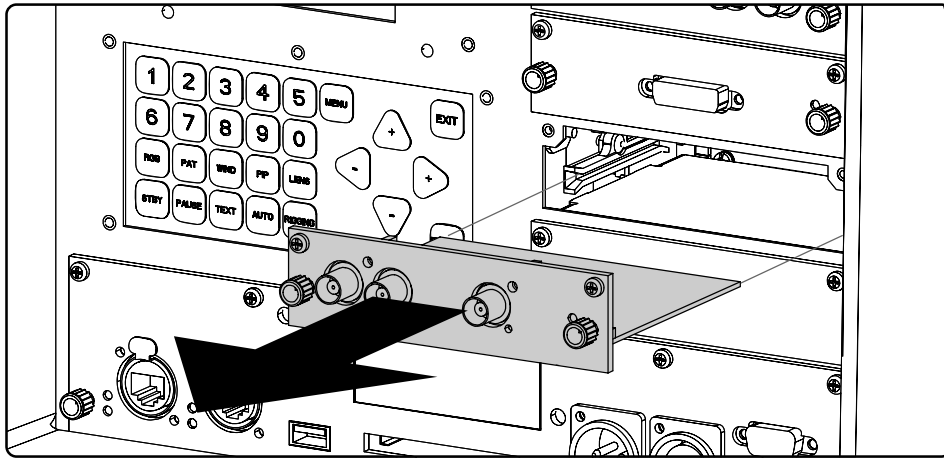

Image 16-6



**CAUTION:** Ensure that all unused input slots of the input & communication unit are always covered with a dummy front plate. After removing one of the input modules, immediately replace with an other one or install a dummy front cover on the unused input slot.

## 16.4 Installation of the lamp house



**WARNING:** This procedure may only be performed by qualified technical service personnel.



**CAUTION:** Never attempt to disassemble the lamp from its housing or to dispose of it. Return it to Barco. Due to its high internal pressure, the lamp may explode in either hot or cold states if improperly handled.

### Necessary tools

7 mm flat screw driver.

### How to install the lamp house of the projector ?

1. Ensure the projector is switched off and the power cord at the projector side is unplugged.
2. Remove the lamp cover, if not removed yet. See "Removal of the lamp cover", page 193.
3. Clasp the lamp house by its handles and gently slide the lamp house into its socket. Note that the compartment is provided with guides (G) to position the lamp house correctly.

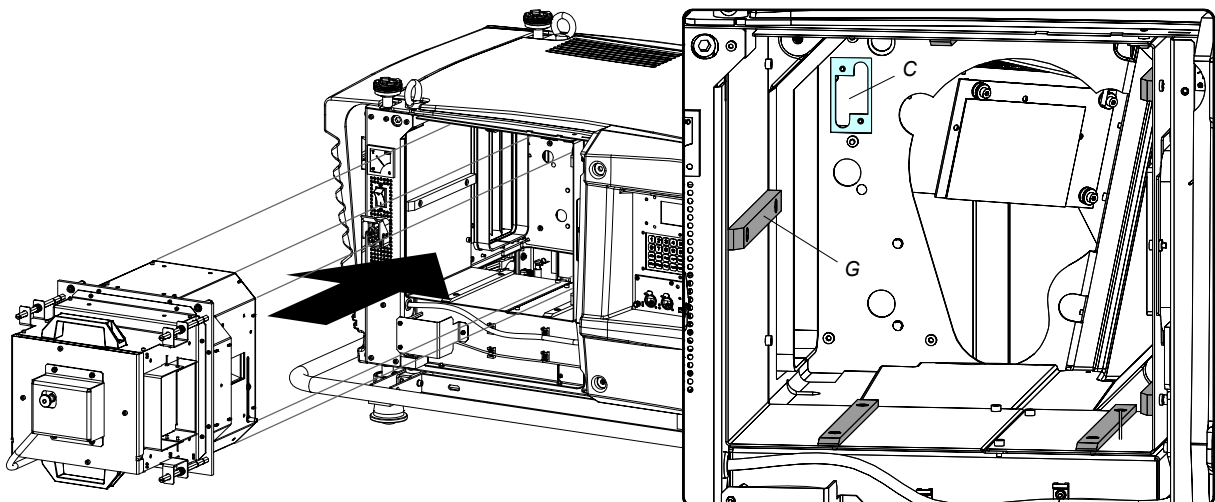

Image 16-7

4. Push the lamp house forward until it slides fully into the projector.
5. Secure the correct position of the lamp house by tightening all three spring lock screws as illustrated.

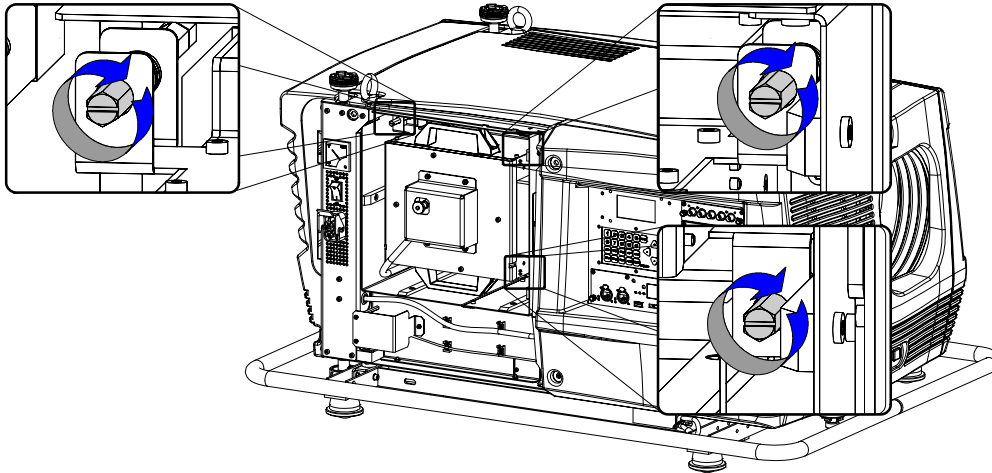

Image 16-8

6. Reinstall the lamp cover of the projector, see "Installation of the lamp cover", page 196.



While starting up the projector, the electronics detect if a lamp is installed. If no lamp is installed, it is not possible to start up the projector.

## 16.5 Installation of the input & communication unit



**WARNING:** This procedure may only be performed by qualified technical service personnel.

### Necessary tools

7 mm flat screw driver.

### How to install the input & communication unit of the projector ?

1. Ensure that the projector is switched off and the power cord at the projector side is unplugged.
2. Remove the input cover, if not removed yet. See "Removal of the input cover", page 193.
3. Hold the input & communication unit by its handles and gently slide the unit into the guides at the bottom of the input & communication socket inside the projector.

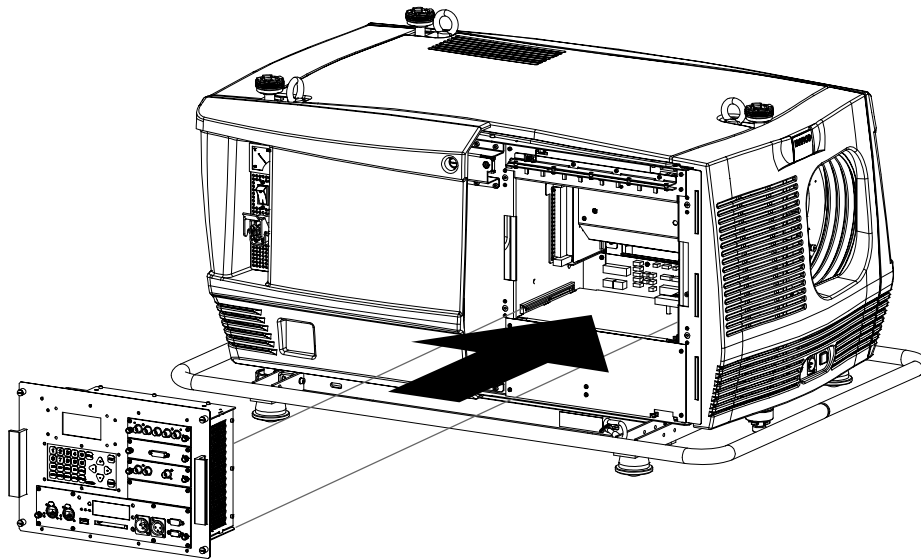

Image 16-9

4. Push the input & communication unit forward until you feel the connectors of the unit fit in their sockets. The back of the front plate of the unit must touch the chassis of the projector.
5. Secure the input & communication unit by fastening the four captive screws in the corners of the unit.

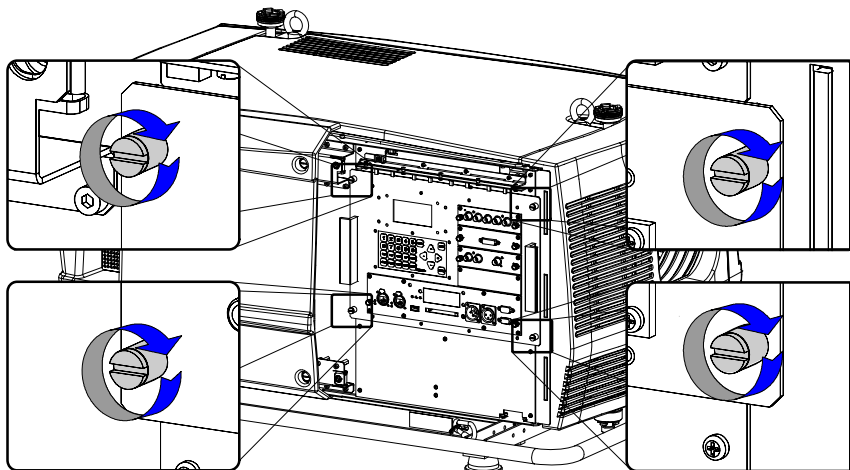

Image 16-10

## 16.6 Installation of an input module



The procedure below is applicable to all input modules of the input & communication unit of the projector.

### Necessary tools

Phillips screw driver PH1.

### How to install an input module into the input & communication unit of the projector ?

1. Switch off the projector and unplug the power cord at the projector side.
2. Slide the input module into the guides of the input slot.

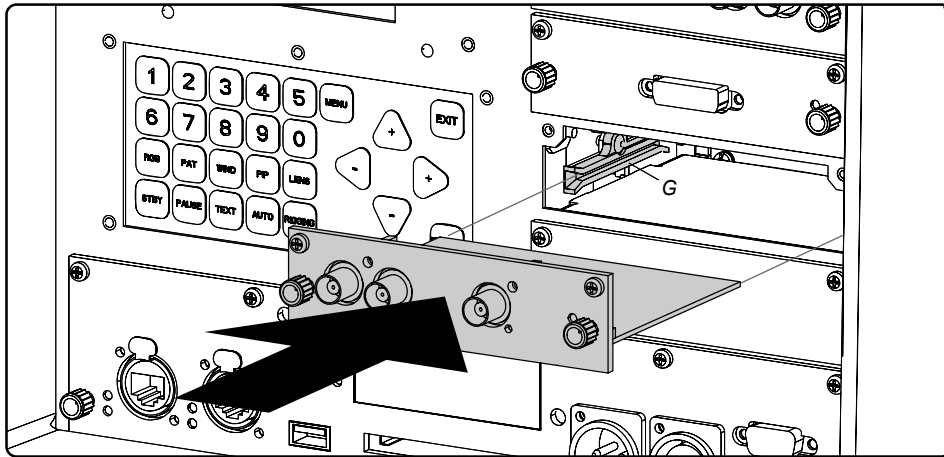

Image 16-11

3. Push the input module forward until you feel that the connector of the input module fit in the socket of the input slot. The back of the front plate of the module must touch the front plate of the input & communication unit.
4. Secure the input module by fastening both captive screws in the top corners of the module.

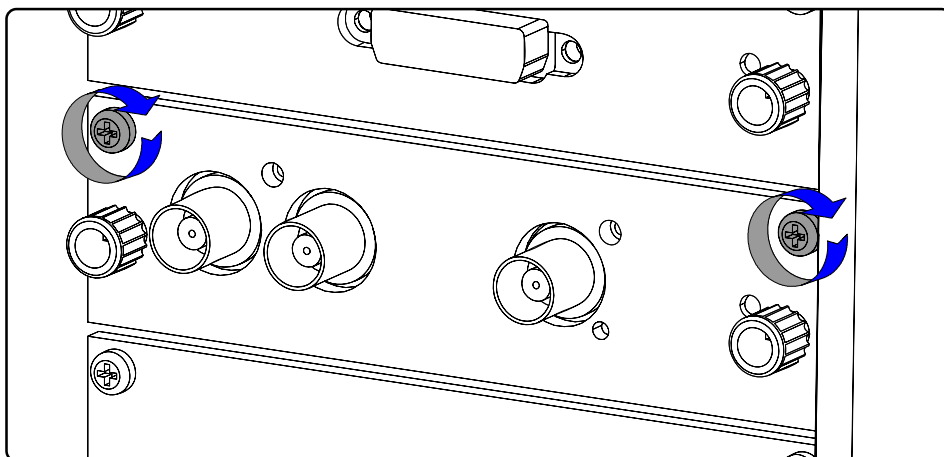

Image 16-12

## 16.7 Realignment of the lamp in its reflector

### Why realigning the lamp ?

With longer run times, the light output of the lamp will decrease, which results in a lower light output on the screen. This light output decrease can be compensated by readjusting the Z-position of the lamp.



**WARNING:** This procedure may only be performed by qualified technical service personnel.

### How to realign the lamp in its reflector ?

1. Remove the cover of the lamp, see "Removal of the lamp cover", page 193.
2. Connect the projector to the local power net, see "Power connection", page 35.
3. Start up the projector, enter the menu structure and select Lamp / Z-axis (for more explanation, see "Z-axis adjustment", page 113)
4. Carefully turn the thumb screw (A) at the rear of the lamp house clockwise for maximum light output. Once over the maximum, turn slightly counterclockwise to reach the maximum light output again.

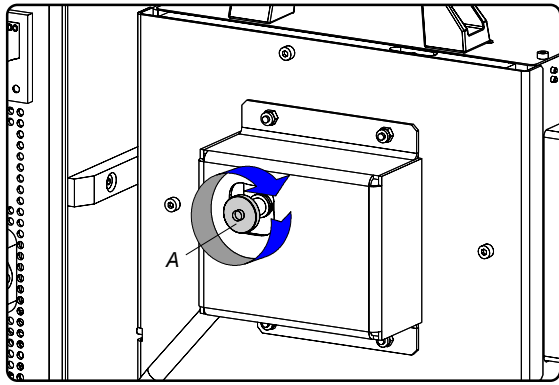

Image 16-13

5. Switch off the projector, wait five minutes and unplug the power cord at the projector side.
6. Reinstall the cover of the lamp, see "Installation of the lamp cover", page 196.

# 17. REMOVAL OF THE PROJECTOR COVERS

## About this chapter

Most maintenance and servicing procedures demand removing one or more of the projector covers to gain access to the parts to maintain or to service. To avoid redundancy, all procedures about cover removing or installing are grouped together in this chapter. The maintenance and servicing procedures also refer to this chapter if required. The procedures in this chapter describe, with detailed step by step actions and illustrations, how to remove or install the projector covers. Note that some covers may only be removed by qualified service personnel, see remarks above each procedure.



**WARNING:** Always switch off the projector and unplug the power cord at the projector side before removing one of the covers.

## Overview

- Removal of the front cover
- Removal of the side cover
- Removal of the lamp cover
- Removal of the input cover
- Installation of the front cover
- Installation of the side cover
- Installation of the lamp cover
- Installation of the input cover

## 17.1 Removal of the front cover

### Necessary tools

7 mm flat screw driver.

### How to remove the front cover of the projector ?

1. Remove the lens. See chapter "Lens removal", page 26.
2. Remove the rubber dust ring from the lens holder. See image 17-1.
3. Release the captive screw at the middle bottom of the front cover, using a flat screw driver.

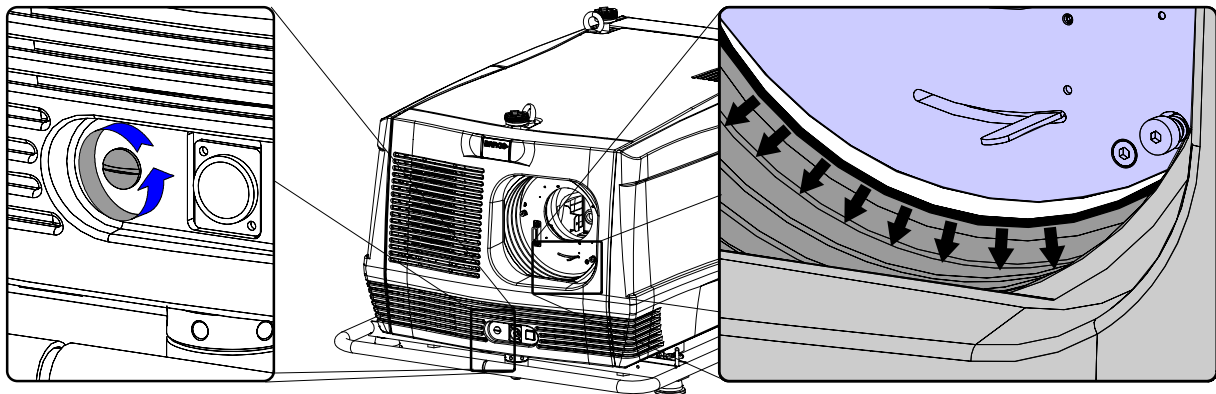

Image 17-1

4. Remove the front cover from the projector doing the following:
  - a) standing in front of the projector, pull the right side of the front cover toward you until the latches release (left side is hinged)
  - b) then slide the front cover to the right to release it from the hinging points.

## 17. Removal of the projector covers

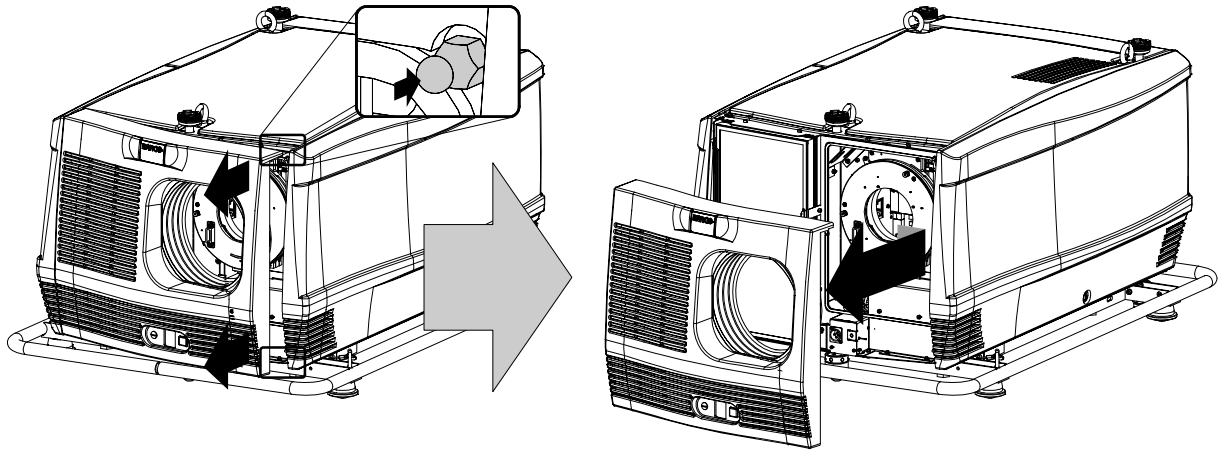

Image 17-2

### 17.2 Removal of the side cover



**CAUTION:** Remove the side cover of the projector only in a clean and dust free area. Never remove the side cover in an area which is subject to airborne contaminants such as that produced by smoke machines or similar.

#### Necessary tools

7 mm flat screw driver.

#### How to remove the side cover of the projector ?

1. Release the captive screw at the middle bottom of the side cover, using a flat screw driver.

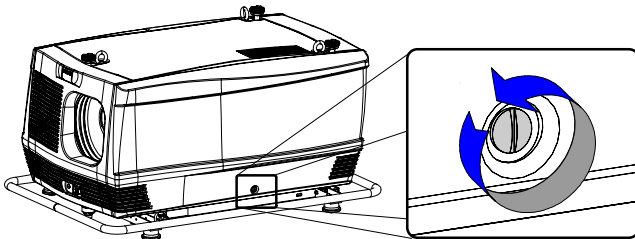

Image 17-3

2. Remove the side cover from the projector doing the following:
  - a) gently pull out the bottom corners (A) of the side cover,
  - b) then gently pull out the top corners (B) of the side cover,
  - c) then move the side cover away from the projector (C).

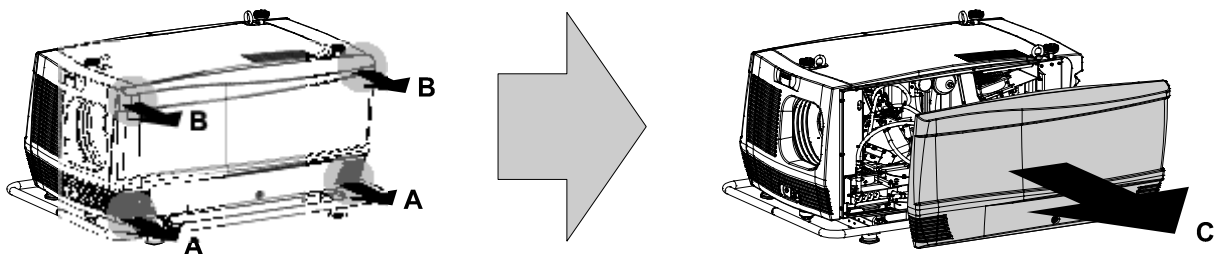

Image 17-4



## 17.3 Removal of the lamp cover



**WARNING:** This procedure may only be performed by qualified technical service personnel.

### Necessary tools

7 mm flat screw driver.

### How to remove the lamp cover of the projector ?

1. Release the two captive screws at the top and bottom right side of the lamp cover, using a flat screw driver.

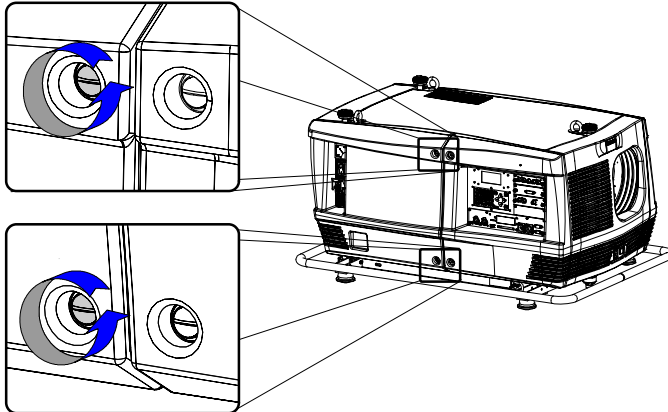

Image 17-5

2. Remove the lamp cover from the projector doing the following:
  - a) gently pull out the left bottom corner (A) of the lamp cover,
  - b) then gently pull out the left top corner (B) of the lamp cover,
  - c) then move the lamp cover away from the projector (C).

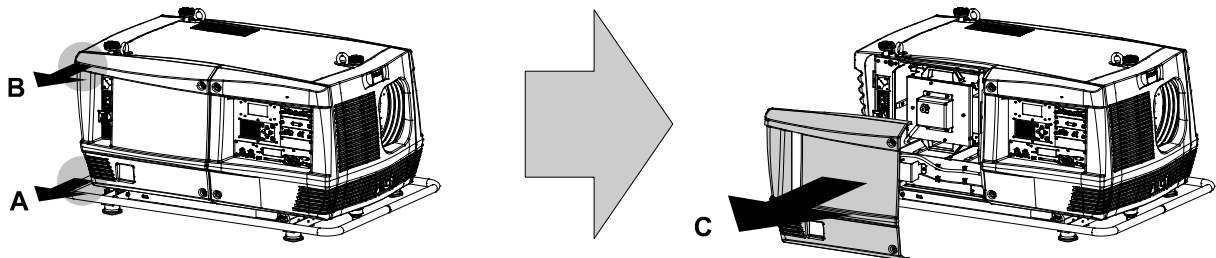

Image 17-6

## 17.4 Removal of the input cover



**WARNING:** This procedure may only be performed by qualified technical service personnel.

### Necessary tools

7 mm flat screw driver.

### How to remove the input cover of the projector ?

1. Release the two captive screws at the top and bottom left side of the input cover, using a flat screw driver.

## 17. Removal of the projector covers

---

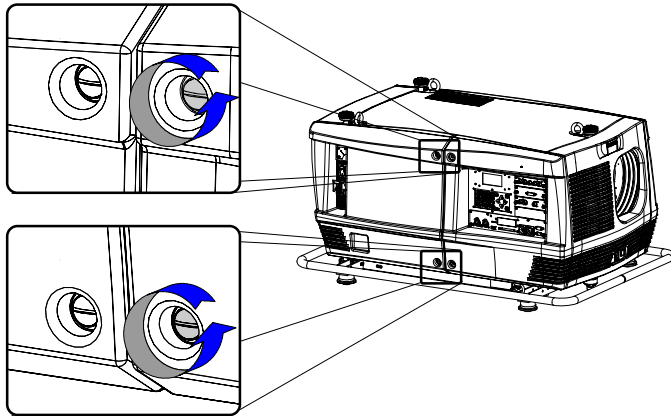

Image 17-7

2. Remove the input cover from the projector doing the following:
  - a) gently pull out the right bottom corner (A) of the input cover,
  - b) then gently pull out the right top corner (B) of the input cover,
  - c) then move the input cover away from the projector (C).

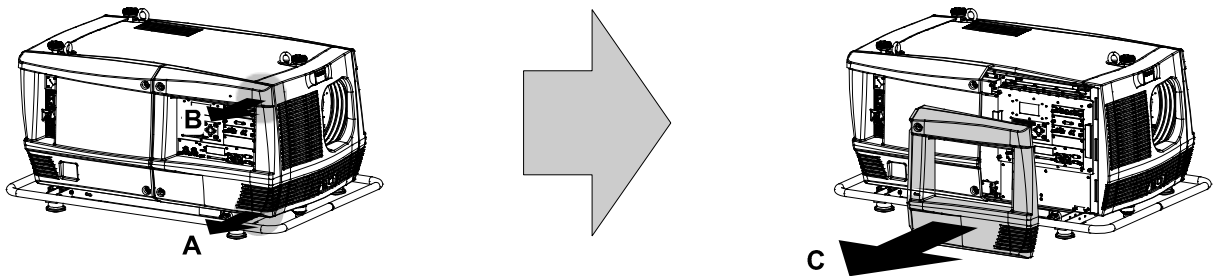

Image 17-8

## 17.5 Installation of the front cover

---

### Necessary tools

7 mm flat screw driver.

### How to install the front cover of the projector ?

1. Check if the front filter is present.
2. Ensure that no lens is mounted.
3. Install the front cover of the projector doing the following:
  - a) first hook in the side of the front cover at the front filter,
  - b) then gently push the other side of the front cover into position,
  - c) ensure that the locking studs in the corners click into their receivers.

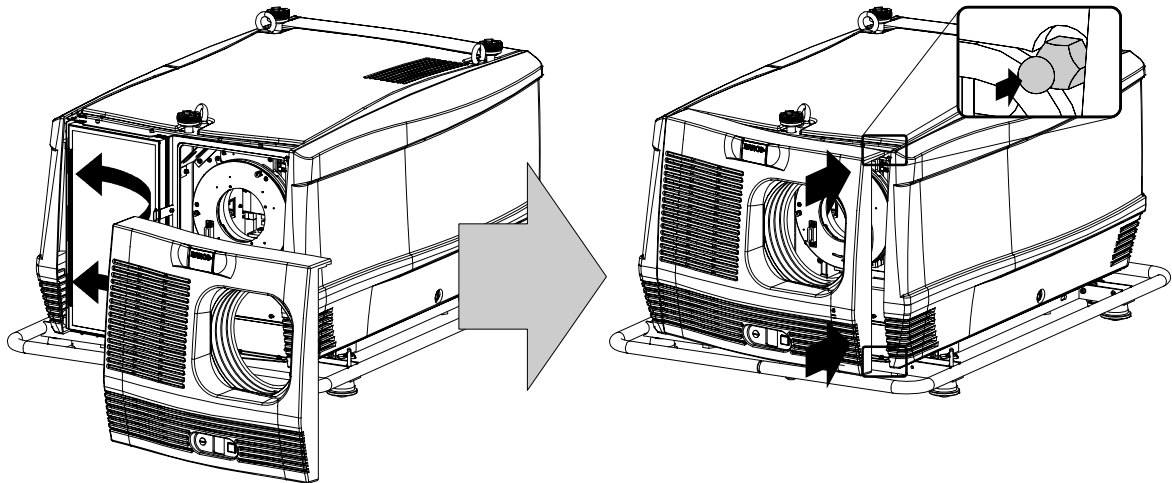

Image 17-9

4. Secure the front cover by locking the captive screw in the middle at the bottom of the front cover.

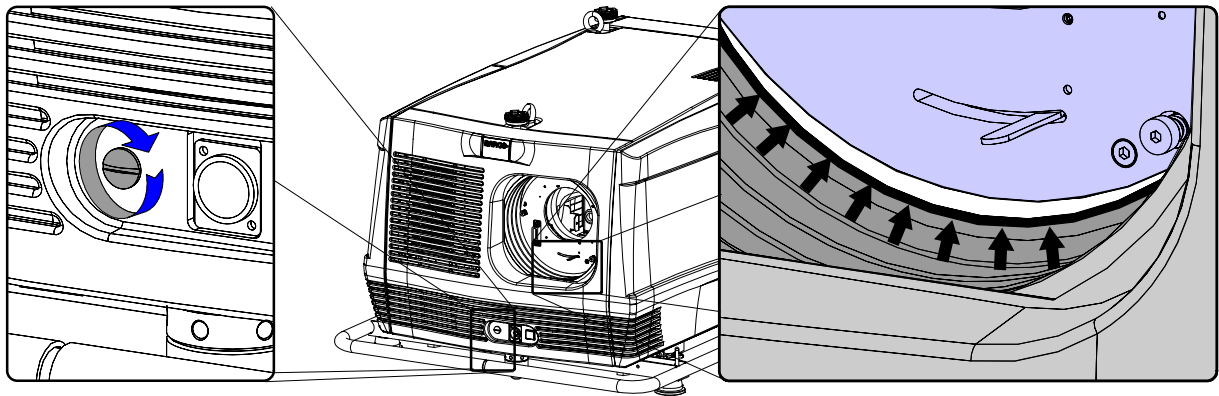

Image 17-10

5. Reinstall the rubber dust ring around the lens holder. See image 17-10.

## 17.6 Installation of the side cover

### Necessary tools

7 mm flat screw driver.

### How to install the side cover of the projector ?

1. Check if the bottom and top filters are present.
2. Check the pressure indicated on the internal manometer of the liquid cooling circuit. This pressure should be between 0,5 and 1 bar. If the pressure is out of range, inform the responsible and qualified technician, so he may take necessary corrective action.

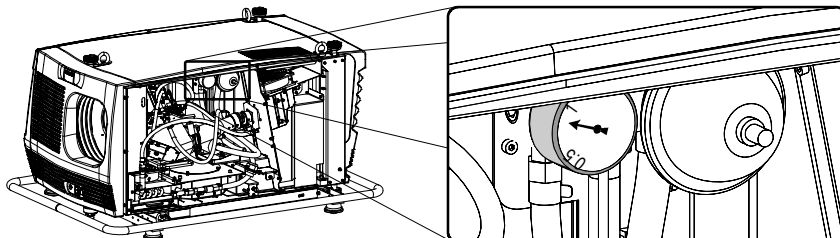

Image 17-11

3. Install the side cover of the projector doing the following:
  - a) Bring the side cover towards its final position (A),
  - b) then gently push the locking studs of the top corners (B) into their receivers,
  - c) then gently push the locking studs of the bottom corners (C) into their receivers.

## 17. Removal of the projector covers

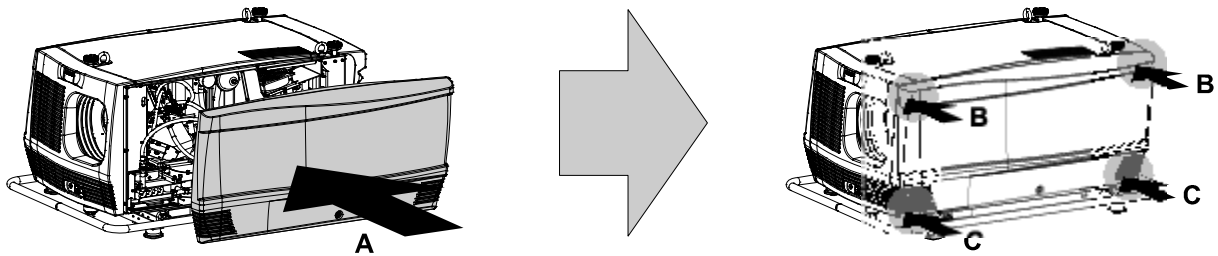

Image 17-12

4. Secure the side cover by locking the captive screw in the middle at the bottom of the side cover.

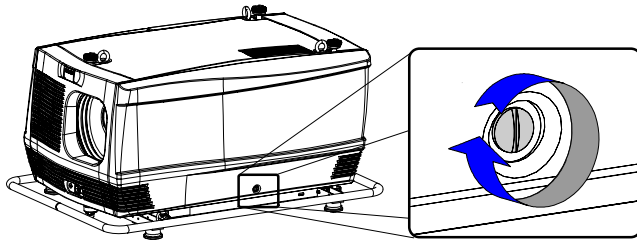

Image 17-13

## 17.7 Installation of the lamp cover

### Necessary tools

7 mm flat screw driver.

### How to install the lamp cover of the projector ?

1. Install the lamp cover of the projector doing the following:
  - a) Bring the lamp cover towards its final position (A),
  - b) then gently push the locking stud at the left top corner (B) into its receiver,
  - c) then gently push the locking stud at the left bottom corner (C) into its receiver.

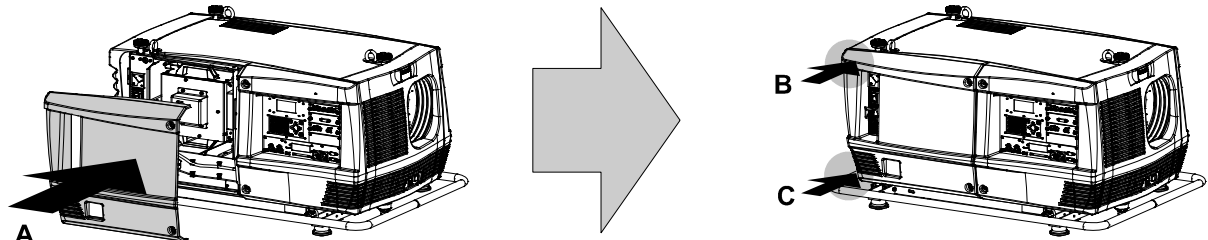

Image 17-14

2. Secure the lamp cover by locking the two captive screws at the right side of the lamp cover.

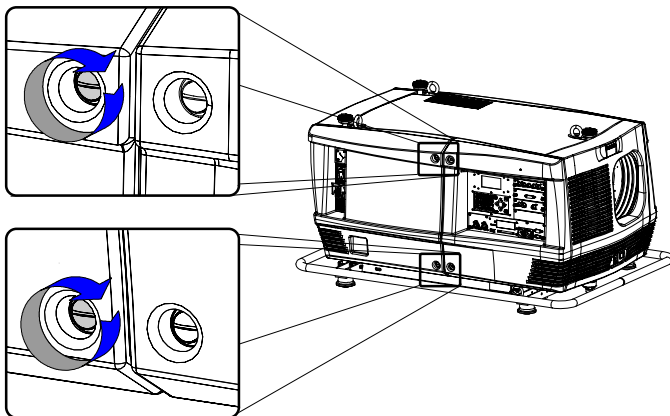

Image 17-15

## 17.8 Installation of the input cover

### Necessary tools

7 mm flat screw driver.

### How to install the input cover of the projector ?

1. Install the input cover of the projector doing the following:
  - a) Bring the input cover towards its final position (A),
  - b) then gently push the locking stud at the right top corner (B) into its receiver,
  - c) then gently push the locking stud at the right bottom corner (C) into its receiver.

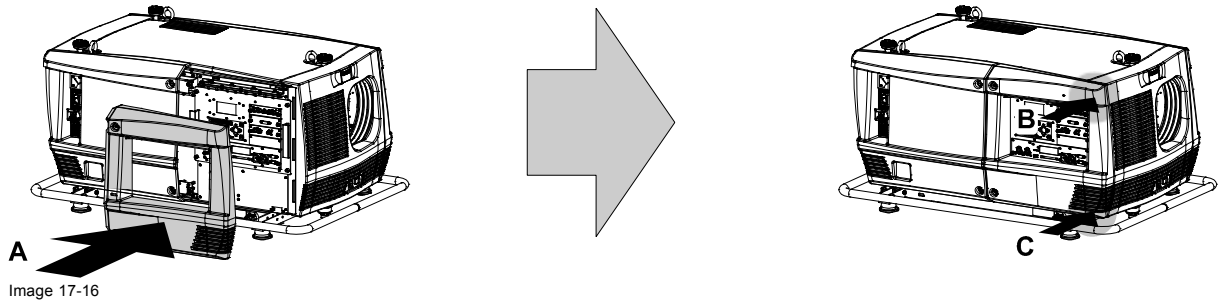

2. Secure the input cover by locking the two captive screws at the left side of the input cover.



# 18. DIMENSIONS

## Overview

- Dimensions of the FLM HD20
- Dimensions of the FLM flight case
- Dimensions of the rigging clamps

## 18.1 Dimensions of the FLM HD20

### Dimensions

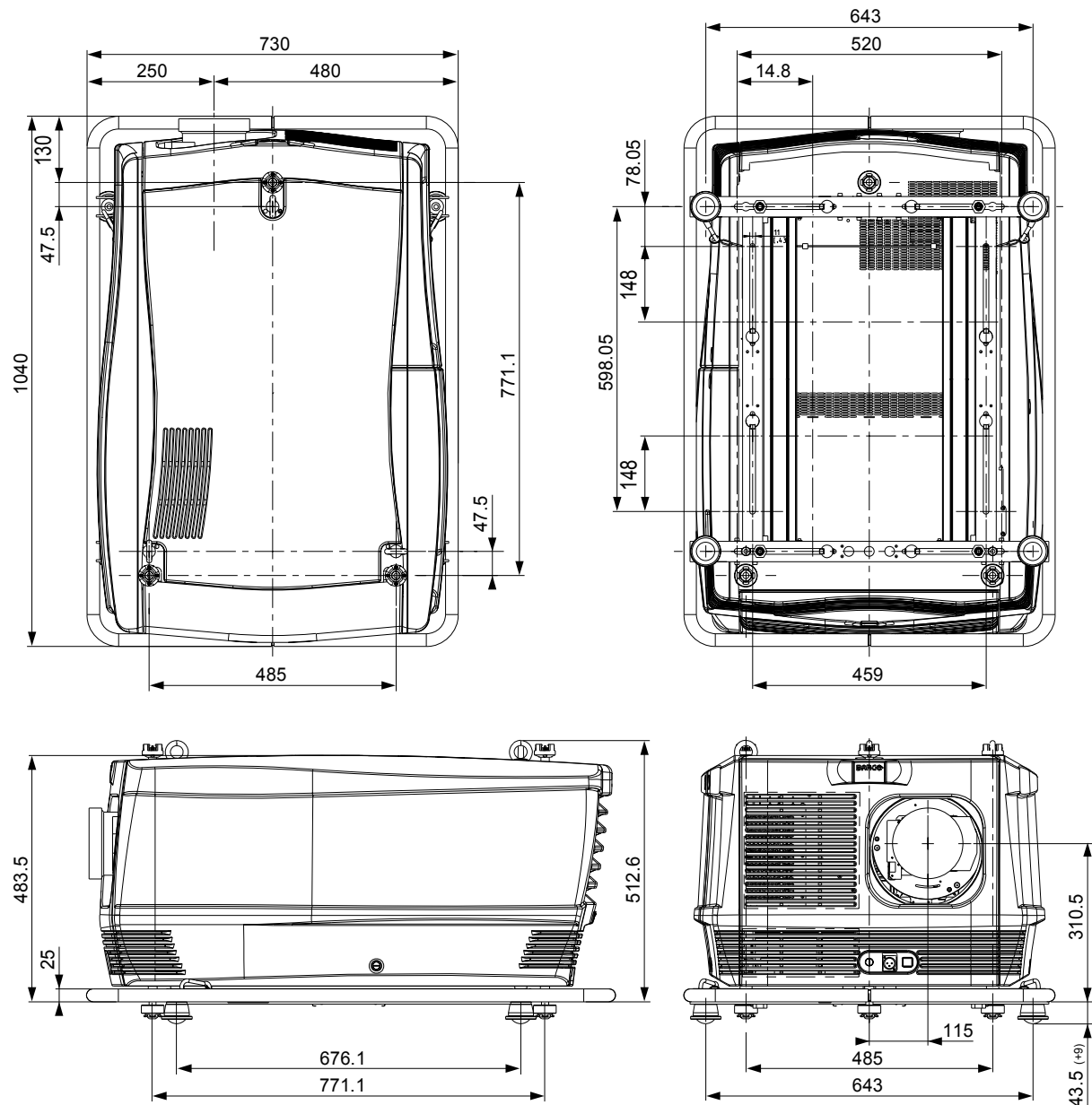

Image 18-1  
Dimensions given in millimeters.

**Point of gravity**

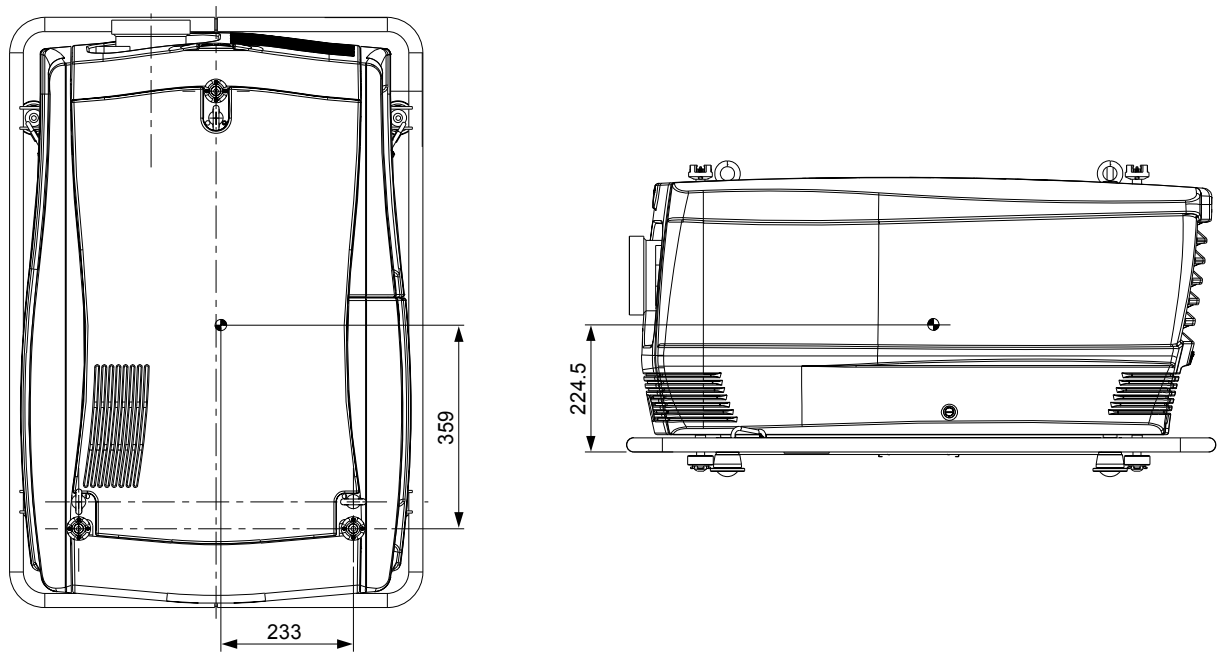

Image 18-2  
Dimensions given in millimeters.

**18.2 Dimensions of the FLM flight case**

**Dimensions**

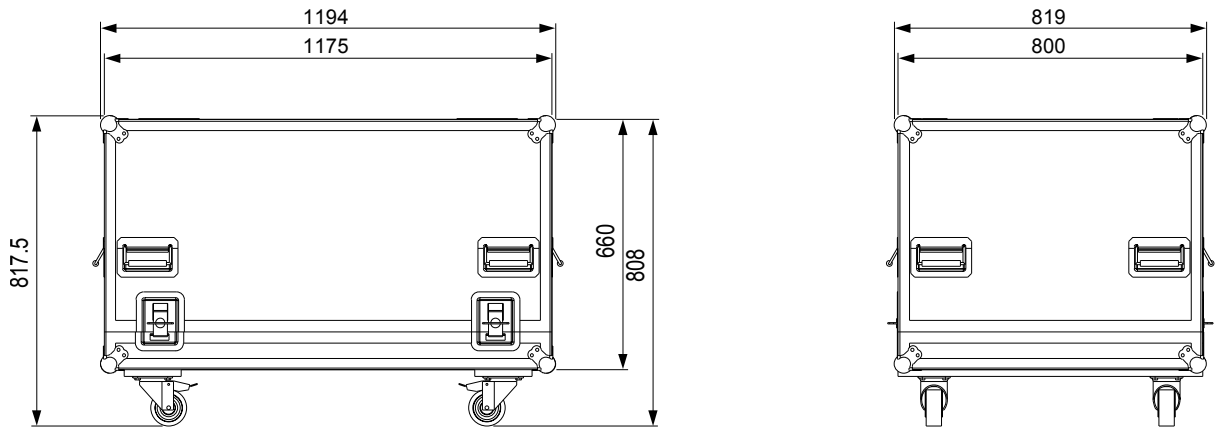

Image 18-3  
Dimensions given in millimeters.



18.3 Dimensions of the rigging clamps

Dimensions

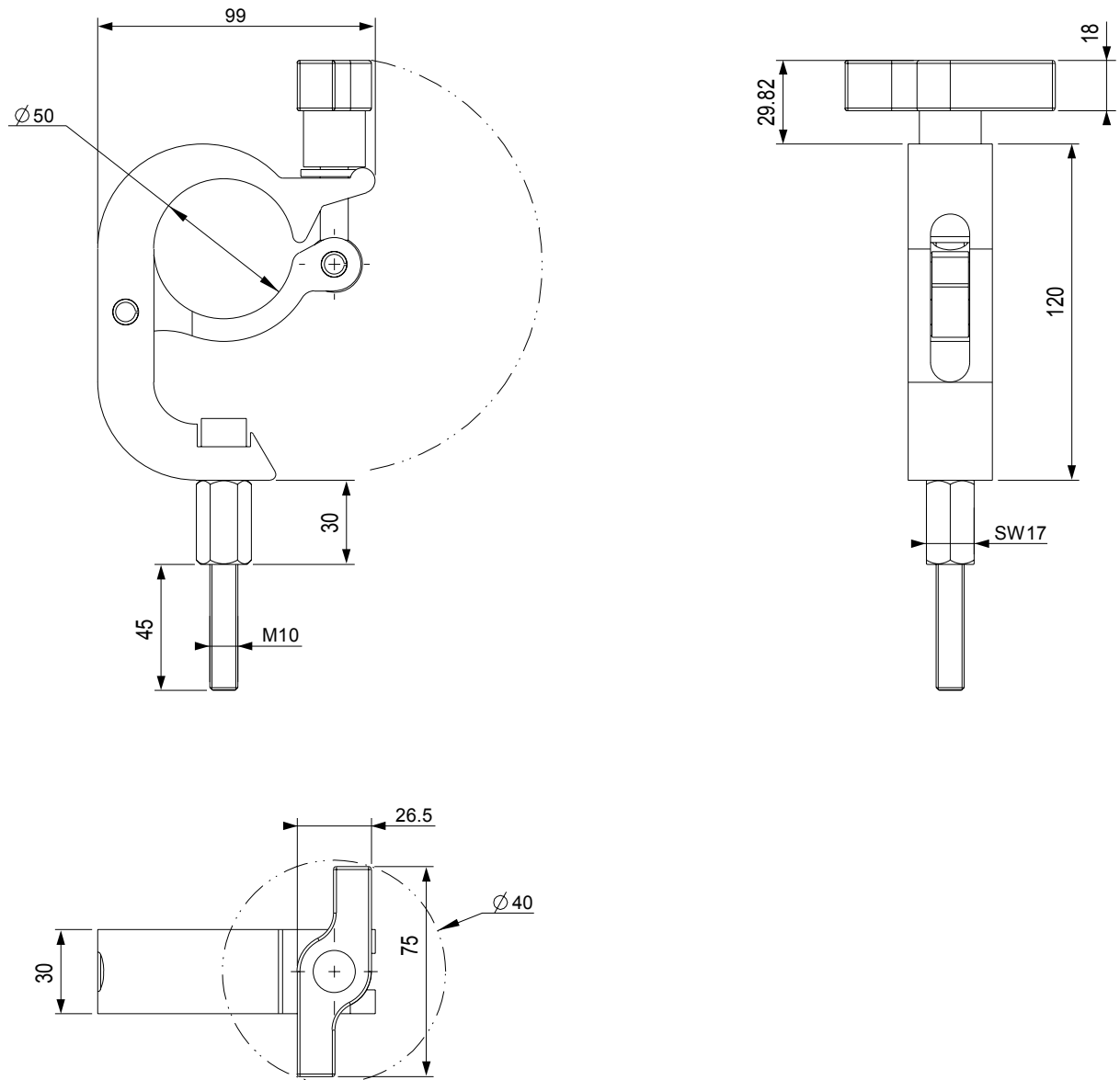

Image 18-4  
Dimensions given in millimeters.



# 19. STANDARD SOURCE FILES

## 19.1 Table overview

### Table overview

The following standard image files are pre-programmed in the projector.

| Name <sup>2</sup> | Fvert<br>Hz <sup>3</sup> | FHor<br>kHz <sup>4</sup> | Fpix<br>MHz <sup>5</sup> | Ptot <sup>6</sup> | Pact <sup>7</sup> | Ltot <sup>8</sup> | Lact <sup>9</sup> |
|-------------------|--------------------------|--------------------------|--------------------------|-------------------|-------------------|-------------------|-------------------|
| 640x350@85        | 85,079                   | 37,860                   | 31,500                   | 832               | 640               | 445               | 350               |
| 640x400@85        | 85,079                   | 37,860                   | 31,500                   | 832               | 640               | 445               | 400               |
| 640x480@60        | 59,940                   | 31,668                   | 25,175                   | 800               | 640               | 525               | 480               |
| 640x480@72        | 72,888                   | 30,288                   | 19,687                   | 832               | 640               | 520               | 480               |
| 640x480@75        | 74,999                   | 37,500                   | 31,500                   | 840               | 640               | 500               | 480               |
| 640x480@85        | 85,009                   | 43,270                   | 36,000                   | 832               | 640               | 509               | 480               |
| 720x400@85        | 85,040                   | 37,928                   | 35,500                   | 936               | 720               | 446               | 400               |
| 800x600@56        | 56,251                   | 35,157                   | 36,001                   | 1024              | 800               | 625               | 600               |
| 800x600@60        | 60,317                   | 37,879                   | 40,000                   | 1056              | 800               | 628               | 600               |
| 800x600@72        | 72,188                   | 48,077                   | 50,000                   | 1040              | 800               | 666               | 600               |
| 800x600@75        | 75,001                   | 46,876                   | 49,501                   | 1056              | 800               | 625               | 600               |
| 800x600@85        | 85,062                   | 53,674                   | 56,250                   | 1048              | 800               | 631               | 600               |
| 848x480@60        | 60,000                   | 31,020                   | 33,750                   | 1088              | 848               | 517               | 480               |
| 1024x768@60       | 60,004                   | 48,363                   | 65,000                   | 1344              | 1024              | 806               | 768               |
| 1024x768@70       | 70,068                   | 56,475                   | 74,999                   | 1328              | 1024              | 806               | 768               |
| 1024x768@75       | 75,030                   | 60,024                   | 78,751                   | 1312              | 1024              | 800               | 768               |
| 1024x768@85       | 84,996                   | 68,677                   | 94,499                   | 1376              | 1024              | 808               | 768               |
| 1152x864@75       | 74,999                   | 67,499                   | 107,999                  | 1600              | 1152              | 900               | 864               |
| 1280x768@60       | 59,870                   | 47,776                   | 79,499                   | 1664              | 1280              | 798               | 768               |
| 1280x768@75       | 74,992                   | 60,288                   | 102,249                  | 1696              | 1280              | 805               | 768               |
| 1280x768@85       | 84,838                   | 68,634                   | 117,502                  | 1712              | 1280              | 809               | 768               |
| 1280x768RB@60     | 59,994                   | 47,396                   | 68,250                   | 1440              | 1280              | 790               | 768               |
| 1280x960@60       | 59,999                   | 59,999                   | 107,998                  | 1800              | 1280              | 1000              | 960               |
| 1280x960@85       | 85,005                   | 85,940                   | 128,505                  | 1728              | 1280              | 1011              | 960               |
| 1280x1024@60      | 60,018                   | 63,980                   | 107,997                  | 1688              | 1280              | 1066              | 1024              |
| 1280x1024@75      | 75,023                   | 79,974                   | 134,997                  | 1688              | 1280              | 1066              | 1024              |
| 1280x1024@85      | 85,027                   | 91,149                   | 157,506                  | 1728              | 1280              | 1072              | 1024              |
| 1360x768@60       | 59,898                   | 47,619                   | 85,333                   | 1792              | 1360              | 795               | 768               |
| 1400x1050@50      | 50,015                   | 54,517                   | 94,641                   | 1736              | 1400              | 1090              | 1050              |
| 1400x1050@60      | 59,979                   | 65,317                   | 121,751                  | 1864              | 1400              | 1089              | 1050              |
| 1400x1050@75      | 74,866                   | 82,277                   | 155,998                  | 1896              | 1400              | 1099              | 1050              |
| 1400x1050@85      | 84,958                   | 93,879                   | 179,497                  | 1912              | 1400              | 1105              | 1050              |

2. Name: name of file, contains the settings.
3. Fvert Hz: vertical frame frequency of the source
4. FHor kHz: horizontal frequency of the source
5. Fpix MHz: pixel frequency
6. Ptot : total pixels on one horizontal line.
7. Pact: active pixels on one horizontal line.
8. Ltot: total lines in one field
9. Lact: active lines in one field.

19. Standard Source Files

| Name <sup>2</sup> | Fvert<br>Hz <sup>3</sup> | FHor<br>kHz <sup>4</sup> | Fpix<br>MHz <sup>5</sup> | Ptot <sup>6</sup> | Pact <sup>7</sup> | Ltot <sup>8</sup> | Lact <sup>9</sup> |
|-------------------|--------------------------|--------------------------|--------------------------|-------------------|-------------------|-------------------|-------------------|
| 1400x1050RB@60    | 59,946                   | 64,742                   | 100,997                  | 1560              | 1400              | 1080              | 1050              |
| 1600x1200@60      | 60,001                   | 75,002                   | 162,004                  | 2160              | 1600              | 1250              | 1200              |
| 1600x1200@65      | 64,998                   | 81,248                   | 175,496                  | 2160              | 1600              | 1250              | 1200              |
| 1600x1200@70      | 69,997                   | 87,497                   | 188,993                  | 2160              | 1600              | 1250              | 1200              |
| 1600x1200@75      | 74,998                   | 93,747                   | 202,414                  | 2160              | 1600              | 1250              | 1200              |
| 1600x1200@85      | 84,998                   | 106,247                  | 229,494                  | 2160              | 1600              | 1250              | 1200              |
| 1792x1344@60      | 60,000                   | 83,640                   | 204,751                  | 2448              | 1792              | 1394              | 1344              |
| 1792x1344@75      | 74,996                   | 106,270                  | 260,999                  | 2456              | 1792              | 1417              | 1344              |
| 1856x1392@60      | 59,995                   | 86,333                   | 218,251                  | 2528              | 1856              | 1439              | 1392              |
| 1920x1140@60      | 60,001                   | 90,001                   | 234,002                  | 2600              | 1920              | 1500              | 1140              |
| 1920x1200@60      | 59,883                   | 74,555                   | 193,235                  | 2592              | 1920              | 1245              | 1200              |
| 1920x1200RB@60    | 59,952                   | 74,041                   | 154,006                  | 2080              | 1920              | 1235              | 1200              |
| 1920x1440@60      | 60,001                   | 90,001                   | 234,002                  | 2600              | 1920              | 1500              | 1200              |
| hd-1280x720@60p   | 60,001                   | 45,000                   | 74,251                   | 1650              | 1280              | 750               | 720               |
| hd-1920x1035@30i  | 60,000                   | 33,720                   | 74,184                   | 2200              | 1920              | 562               | 517               |
| hd-1920x1080@24p  | 24,000                   | 27,000                   | 74,250                   | 2750              | 1920              | 1125              | 1080              |
| hd-1920x1080@24sf | 48,001                   | 54,002                   | 148,504                  | 2750              | 1920              | 1125              | 1080              |
| hd-1920x1080@25i  | 50,044                   | 28,125                   | 74,249                   | 2640              | 1920              | 562               | 540               |
| hd-1920x1080@25p  | 25,000                   | 28,125                   | 74,249                   | 2640              | 1920              | 1125              | 1080              |
| hd-1920x1080@30i  | 60,000                   | 33,720                   | 74,184                   | 2200              | 1920              | 562               | 540               |
| hd-1920x1080@30p  | 30,000                   | 33,750                   | 74,249                   | 2200              | 1920              | 1125              | 1080              |
| hd-1920x1080@25i  | 50,000                   | 31.25                    | 74,250                   | 2376              | 1920              | 625               | 540               |
| hd-1920x1080@60p  | 60,011                   | 67,513                   | 148,528                  | 2200              | 1920              | 1125              | 1080              |
| VIDEO525          | 62,437                   | 15,734                   | 13,500                   | 858               | 712               | 252               | 242               |
| VIDEO525p         | 59,940                   | 31,468                   | 27,000                   | 858               | 712               | 525               | 484               |
| VIDEO625          | 50,080                   | 15,625                   | 13,500                   | 864               | 702               | 312               | 287               |
| VIDEO625p         | 50,080                   | 31,250                   | 27,000                   | 864               | 702               | 625               | 574               |
| no-signal         | 100,00                   | 20,000                   | 8,000                    | 400               | 300               | 200               | 100               |
| no-signal-i       | 100,00                   | 20,000                   | 8,000                    | 400               | 300               | 200               | 100               |

Table 19-1

## 20. DMX CHART

### Overview

- DMX chart, basic
- DMX chart, Extended
- DMX chart, Full

### 20.1 DMX chart, basic

#### Overview

| Chan<br>nel | Function             | Value     | Action              |
|-------------|----------------------|-----------|---------------------|
| 1           | Intensity            | 0 - 5     | Mechanical shutter  |
|             |                      | 0 - 255   | Electronic contrast |
| 2           | Function selection   | 0 - 7     | no function         |
|             |                      | 8 - 15    | Layout 1            |
|             |                      | 16 - 23   | Layout 2            |
|             |                      | 24 - 31   | Layout 3            |
|             |                      | 32 - 39   | Layout 4            |
|             |                      | 40 - 47   | Layout 5            |
|             |                      | 48 - 55   | Layout 6            |
|             |                      | 56 - 63   | Layout 7            |
|             |                      | 64 - 71   | Layout 8            |
|             |                      | 72 - 79   | Layout 9            |
|             |                      | 80 - 87   | Layout 10           |
|             |                      | 88 - 95   | Input select 1      |
|             |                      | 96 - 103  | Input select 2      |
|             |                      | 104 - 111 | Input select 3      |
|             |                      | 112 - 119 | Input select 4      |
|             |                      | 120 - 127 |                     |
|             |                      | 128 - 135 |                     |
|             |                      | 136 - 143 |                     |
|             |                      | 144 - 151 |                     |
|             |                      | 152 - 159 |                     |
| 160 - 167   |                      |           |                     |
| 168 - 175   |                      |           |                     |
| 176 - 183   |                      |           |                     |
| 184 - 207   |                      |           |                     |
| 208 - 215   | Power On / Lamp On   |           |                     |
| 216 - 223   | Power Off / Lamp Off |           |                     |
| 224 - 255   |                      |           |                     |

## 20.2 DMX chart, Extended

### Overview

| Channel   | Function        | Value     | Default | Actions   |
|-----------|-----------------|-----------|---------|---|
| 1         | Intensity       | 0 - 5     |         | Mechanical shutter closed   |
|           |                 | 0 - 255   |         | Contrast 0 - channel 3  |
| 2         | Brightness      | 0 - 255   | 128     | Adjusts the brightness between 0 and 100% (SLM/XLM doesn't adjust on DVI) |
| 3         | Contrast        | 0 - 255   | 128     | Adjusts the contrast between 0 and 100% (SLM/XLM doesn't adjust on DVI)   |
| 4         | Input selection | 0 - 7     |         | No function   |
|           |                 | 8 - 15    |         | Layout 1 (execution takes 5 sec)  |
|           |                 | 16 - 23   |         | Layout 2 (execution takes 5 sec)  |
|           |                 | 24 - 31   |         | Layout 3 (execution takes 5 sec)  |
|           |                 | 32 - 39   |         | Layout 4 (execution takes 5 sec)  |
|           |                 | 40 - 47   |         | Layout 5 (execution takes 5 sec)  |
|           |                 | 48 - 55   |         | Layout 6 (execution takes 5 sec)  |
|           |                 | 56 - 63   |         | Layout 7 (execution takes 5 sec)  |
|           |                 | 64 - 71   |         | Layout 8 (execution takes 5 sec)  |
|           |                 | 72 - 79   |         | Layout 9 (execution takes 5 sec)  |
|           |                 | 80 - 87   |         | Layout 10 (execution takes 5 sec)   |
|           |                 | 88 - 95   |         | Input select 1  |
|           |                 | 96 - 103  |         | Input select 2  |
|           |                 | 104 - 111 |         | Input select 3  |
|           |                 | 112 - 119 |         | Input select 4  |
|           |                 | 120 - 127 |         |   |
|           |                 | 128 - 135 |         |   |
|           |                 | 136 - 143 |         |   |
|           |                 | 144 - 151 |         |   |
|           |                 | 152 - 159 |         |   |
| 160 - 167 |                 |           |         |   |
| 168 - 175 |                 |           |         |   |
| 176 - 183 |                 |           |         |   |
| 184 - 255 | No function     |           |         |   |
| 5         | Lens control    | 0 - 7     |         | No function   |
|           |                 | 8 - 15    |         | Lens shift Right  |
|           |                 | 16 - 23   |         | No function   |
|           |                 | 24 - 31   |         | Lens shift Left   |
|           |                 | 32 - 39   |         | No function   |
|           |                 | 40 - 47   |         | Lens shift up   |
|           |                 | 48 - 55   |         | No function   |
|           |                 | 56 - 63   |         | Lens shift down   |
|           |                 | 64 - 231  |         | No function   |
|           |                 | 232 - 239 |         | Return lens to center (if held for 5 seconds)                             |
|           |                 | 240 - 247 |         | Calibrate lens zoom + focus (if held for 5 seconds and channel 1 < 6)     |
|           |                 | 248 - 255 |         | No function   |
|           |                 | 6         |         | Foxus (MSB)   |
| 7         | Focus (LSB)     | 0 - 255   |         | Fine focus adjustment   |
| 8         | Zoom (MSB)      | 0 - 255   |         | Coarse zoom adjustment  |

| Channel   | Function   | Value                                       | Default | Actions              |
|-----------|------------|---|---------|----------------------|
| 9         | Zoom (LSB) | 0 - 255                                     |         | Fine zoom adjustment |
| 10        | Control    | 0 - 7                                       |         | Lamp power 100%      |
|           |            | 8 - 15                                      |         | Lamp power 98%       |
|           |            | 16 - 23                                     |         | Lamp power 96%       |
|           |            | 24 - 31                                     |         | Lamp power 94%       |
|           |            | 32 - 39                                     |         | Lamp power 91%       |
|           |            | 40 - 47                                     |         | Lamp power 89%       |
|           |            | 48 - 55                                     |         | Lamp power 86%       |
|           |            | 56 - 63                                     |         | Lamp power 84%       |
|           |            | 64 - 71                                     |         | Lamp power 82%       |
|           |            | 72 - 79                                     |         | Lamp power 80%       |
|           |            | 80 - 87                                     |         | Lamp power 78%       |
|           |            | 88 - 95                                     |         | Lamp power 76%       |
|           |            | 96 - 103                                    |         | Lamp power 74%       |
|           |            | 104 - 111                                   |         | Lamp power 72%       |
|           |            | 112 - 119                                   |         | Lamp power 70%       |
|           |            | 120 - 127                                   |         | Lamp power 68%       |
|           |            | 128 - 135                                   |         | Lamp power 66%       |
|           |            | 136 - 143                                   |         | Lamp power 64%       |
|           |            | 144 - 151                                   |         | Lamp power 62%       |
|           |            | 152 - 159                                   |         | Lamp power 60%       |
| 160 - 167 |            | No function                                 |         |                      |
| 168 - 175 |            | DMX buffer 4 (Not used)                     |         |                      |
| 176 - 183 |            | DMX buffer 8 (Not used)                     |         |                      |
| 184 - 191 |            | DMX buffer off (Not used)                   |         |                      |
| 192 - 199 |            | DMX buffer clear (Not used)                 |         |                      |
| 200 - 207 |            | No function                                 |         |                      |
| 208 - 215 |            | Power On / Lamp On (if held for 5 seconds)  |         |                      |
| 216 - 223 |            | Stand by / Lamp Off (if held for 5 seconds) |         |                      |
| 224 - 255 |            | No function                                 |         |                      |

## 20.3 DMX chart, Full

### Overview

| Channel | Function   | Value   | Default | Action  |
|---------|------------|---------|---------|---|
| 1       | Intensity  | 0 - 5   |         | Mechanical shutter closed   |
|         |            | 6 - 255 |         | Contrast 0 - channel 3  |
| 2       | Brightness | 0 - 255 | 128     | Adjusts the brightness between 0 and 100% (SLM/XLM doesn't adjust on DVI) |
| 3       | Contrast   | 0 - 255 | 128     | Together with channel 1   |

20. DMX chart

| Chan-<br>nel | Function        | Value     | Default | Action  |
|--------------|-----------------|-----------|---------|---|
| 4            | Input selection | 0 - 7     |         | No function   |
|              |                 | 8 - 15    |         | Layout 1 (execution takes 5 sec)  |
|              |                 | 16 - 23   |         | Layout 2 (execution takes 5 sec)  |
|              |                 | 24 - 31   |         | Layout 3 (execution takes 5 sec)  |
|              |                 | 32 - 39   |         | Layout 4 (execution takes 5 sec)  |
|              |                 | 40 - 47   |         | Layout 5 (execution takes 5 sec)  |
|              |                 | 48 - 55   |         | Layout 6 (execution takes 5 sec)  |
|              |                 | 56 - 63   |         | Layout 7 (execution takes 5 sec)  |
|              |                 | 64 - 71   |         | Layout 8 (execution takes 5 sec)  |
|              |                 | 72 - 79   |         | Layout 9 (execution takes 5 sec)  |
|              |                 | 80 - 87   |         | Layout 10 (execution takes 5 sec)   |
|              |                 | 88 - 95   |         | Input select 1  |
|              |                 | 96 - 103  |         | Input select 2  |
|              |                 | 104 - 111 |         | Input select 3  |
|              |                 | 112 - 119 |         | Input select 4  |
|              |                 | 120 - 127 |         |   |
|              |                 | 128 - 135 |         |   |
|              |                 | 136 - 143 |         |   |
|              |                 | 144 - 151 |         |   |
|              |                 | 152 - 159 |         |   |
| 160 - 167    |                 |           |         |   |
| 168 - 175    |                 |           |         |   |
| 176 - 183    |                 |           |         |   |
| 184 - 255    | No function     |           |         |   |
| 5            | Function select | 0 - 31    |         | No function   |
|              |                 | 32 - 63   |         | Focus motor   |
|              |                 | 64 - 95   |         | Zoom motor  |
|              |                 | 96 - 127  |         | Lens shift Right Left   |
|              |                 | 128 - 159 |         | Lens shift Up Down  |
|              |                 | 160 - 191 |         | Power On / Lamp On (together with channel 6 and 7 held in 255 for 5 sec)  |
|              |                 | 192 - 223 |         | Stand By / Lamp Off (together with channel 6 and 7 held in 255 for 5 sec) |
|              |                 | 224 - 255 |         | Return lens to center position (if held for 5 seconds)                    |
| 6            | Motor Go >>     | 0 - 31    |         | Stop  |
|              |                 | 32 - 63   |         | Run   |
|              |                 | 64 - 223  |         | No function   |
|              |                 | 224 - 255 |         | Command (see channel 5)   |
| 7            | Motor Go <<     | 0 - 31    |         | Stop  |
|              |                 | 32 - 63   |         | Run   |
|              |                 | 64 - 223  |         | No function   |
|              |                 | 224 - 255 |         | Command (see channel 5)   |
| 8            | Free            | 0 - 255   |         |   |



| Channel   | Function   | Value          | Default | Action          |
|-----------|------------|----------------|---------|-----------------|
| 9         | Lamp Power | 0 - 26         | 0       | Powered at 100% |
|           |            | 27 - 52        |         | Powered at 98%  |
|           |            | 53 - 79        |         | Powered at 96%  |
|           |            | 80 - 105       |         | Powered at 94%  |
|           |            | 106 - 131      |         | Powered at 91%  |
|           |            | 132 - 157      |         | Powered at 89%  |
|           |            | 158 - 183      |         | Powered at 86%  |
|           |            | 184 - 209      |         | Powered at 84%  |
|           |            | 210 - 235      |         | Powered at 82%  |
| 236 - 255 |            | Powered at 80% |         |                 |
| 10        | Free       | 0 - 255        |         |                 |



## 21. TROUBLESHOOTING

### 21.1 Error codes

#### Overview

When the error code is preceded by a '-' sign, then the error means a real error for the projector.

When the error code is preceded by a '+' sign, then the error code means a warning. The projector does not fail yet, but take care for the warning and try to resolve the problem. A warning state can turn into an error state.

Not all error codes can have two states. When the state is available, it is indicated by a Yes in the overview table. When the state is not available, it is indicated by a No.

| Error code        | Description                | Error | Warning | Caused by  | Action   |
|-------------------|----------------------------|-------|---------|--|--|
| 1000<br>↓<br>1017 | Wrong lamp parameters      | Yes   | -       | Wrong lamp/ no communication with lamp   | Check lamp type<br>Call a qualified service engineer   |
| 1499              |                            |       |         |  |  |
| 1498              |                            |       |         |  |  |
| 1699              | Formatter busy             |       |         |  |  |
| 1698              | Formatter address          |       |         |  |  |
| 1697              | Formatter init failed      | Yes   | -       | no communication with formatter ctrl   | Call a qualified service engineer  |
| 1696              | Formatter ctrl init failed | Yes   | -       | no communication with formatter ctrl   | Call a qualified service engineer  |
| 1695              | Red form. start failed     | Yes   | -       | no communication with red formatter  | Call a qualified service engineer  |
| 1694              | Green form. start failed   | Yes   | -       | no communication with green formatter  | Call a qualified service engineer  |
| 1693              | Blue form. start failed    | Yes   | -       | no communication with blue formatter   | Call a qualified service engineer  |
| 1692              | Form. PWRGood              | Yes   | -       | formatter 'Power Good' signal not OK   | Call a qualified service engineer  |
| 2000              | No lps detected            | Yes   | -       | no communication with lamp power supply  | Call a qualified service engineer  |
| 2001              | Mains voltage too low      | Yes   | -       | mains voltage too low  |  |
| 2002              | Lamp start failed          | Yes   | -       | Hot restrike<br>Lamp with many strikes<br>maximum run time exceeded<br>Lamp or LPS or SPG failed | Let cool down the lamp for at least 5 minutes. Retry a few times.<br>Replace the lamp with a new one<br>Replace LPS or SPG or cabling. |
| 2003              | Main voltage too high      | Yes   | -       | mains voltage too high   |  |
| 2004              | Lamp goes out              | Yes   | -       |  | Call qualified service engineer  |
| 2005              | Lamp stop failed           | Yes   | -       |  | Call qualified service engineer  |
| 2201              | PFC start failed           | Yes   | -       | LPS (address 0x20)   | Replace LPS  |
| 2501              | PFC start failed           | Yes   | -       | LPS (address 0x22)   | Replace LPS  |
| 2801              | PFC start failed           | Yes   | -       | LPS (address 0x28)   | Replace LPS  |
| 2202              | LPS start failed           | Yes   | -       | LPS (address 0x20)   | Replace LPS  |
| 2502              | LPS start failed           | Yes   | -       | LPS (address 0x22)   | Replace LPS  |

## 21. Troubleshooting

| Error code | Description            | Error | Warning | Caused by  | Action   |
|------------|------------------------|-------|---------|--|--|
| 2802       | LPS start failed       | Yes   | -       | LPS (address 0x28)   | Replace LPS  |
| 2203       | BOOST start failed     | Yes   | -       | LPS (address 0x20)   | Replace LPS  |
| 2503       | BOOST start failed     | Yes   | -       | LPS (address 0x22)   | Replace LPS  |
| 2803       | BOOST start failed     | Yes   | -       | LPS (address 0x28)   | Replace LPS  |
| 2206       | Lamp ignition failed   | Yes   | -       | hot restrike,<br>lamp with many strikes, maximum run time exceeded   | Let cool down the lamp for at least 3 minutes. Replace the lamp or SPG with a new one If problem persists, call a qualified service engineer |
| 2506       | Lamp ignition failed   | Yes   | -       | hot restrike,<br>lamp with many strikes, maximum run time exceeded   | Let cool down the lamp for at least 3 minutes. Replace the lamp or SPG with a new one If problem persists, call a qualified service engineer |
| 2806       | Lamp ignition failed   | Yes   | -       | hot restrike,<br>lamp with many strikes, maximum run time exceeded   | Let cool down the lamp for at least 3 minutes. Replace the lamp or SPG with a new one If problem persists, call a qualified service engineer |
| 2207       | Lamp voltage range     | Yes   | -       | lamp voltage too high or too low                                     | Replace lamp   |
| 2507       | Lamp voltage range     | Yes   | -       | lamp voltage too high or too low                                     | Replace lamp   |
| 2807       | Lamp voltage range     | Yes   | -       | lamp voltage too high or too low                                     | Replace lamp   |
| 2208       | Lamp power range       | Yes   | -       | lamp voltage too high or too low                                     | Replace lamp   |
| 2508       | Lamp power range       | Yes   | -       | lamp voltage too high or too low                                     | Replace lamp   |
| 2808       | Lamp power range       | Yes   | -       | lamp voltage too high or too low                                     | Replace lamp   |
| 4000       | Incompatible hardware  | Yes   | No      | Incompatible hardware used   | Change to correct hardware   |
| 4199       | FIB reset failed       | Yes   | -       | no communication with FIB  | Call a qualified service engineer  |
| 5098       | Flash full             | Yes   | -       | Internal Backup device has reached its maximum capacity              | Call a qualified service engineer  |
| 5097       | Flash management full  | Yes   | -       | Internal Backup device has reached its maximum capacity              | Call a qualified service engineer  |
| 5096       | Storing unsuccessful   | Yes   | -       | Storing the custom settings into internal backup device has failed   | If problem persists, call a qualified service engineer   |
| 5095       | Restoring unsuccessful | Yes   | -       | Restoring the custom settings from internal backup device has failed | If problem persists, call a qualified service engineer   |
| 6099       |                        |       |         |  |  |
| 6098       |                        |       |         |  |  |
| 7698       | Light pipe temp high   | Yes   | Yes     | High temperature on light pipe entry                                 | If problem persists, call a qualified service engineer   |
| 7697       | Light pipe temp open   | Yes   | Yes     | Temperature sensor on light pipe not connected                       | Call a qualified service engineer  |
| 7696       | Light pipe temp short  | Yes   | Yes     | Temperature sensor on light pipe shorted                             | Call a qualified service engineer  |
| 7695       | Red front DMD temp low | No    | Yes     | Low temperature on red DMD   | Switching on the lamp will heat up the DMD   |

| Error code | Description                | Error | Warning | Caused by   | Action   |
|------------|----------------------------|-------|---------|---|--|
| 7694       | Red front DMD temp high    | Yes   | Yes     | High temperature on red DMD                                 | Check if air slots are free.<br>Clean air filters.<br>If problem persists, call a qualified service engineer |
| 7693       | Red front DMD temp open    | Yes   | Yes     | Temperature sensor on Red DMD not connected                 | Call a qualified service engineer  |
| 7692       | Red front DMD temp short   | Yes   | Yes     | Temperature sensor on Red DMD shorted                       | Call a qualified service engineer  |
| 7691       | Green front DMD temp low   | No    | Yes     | Low temperature on green DMD                                | Switching on the lamp will heat up the DMD   |
| 7690       | Green front DMD temp high  | Yes   | Yes     | High temperature on green DMD                               | Check if air slots are free.<br>Clean air filters.<br>If problem persists, call a qualified service engineer |
| 7689       | Green front DMD temp open  | Yes   | Yes     | Temperature sensor on green DMD not connected               | Call a qualified service engineer  |
| 7888       | Green front DMD temp short | Yes   | Yes     | Temperature sensor on green DMD shorted                     | Call a qualified service engineer  |
| 7687       | Blue front DMD temp low    | Yes   | -       | Low temperature on blue DMD                                 | Switching on the lamp will heat up the DMD   |
| 7686       | Blue front DMD temp high   | Yes   | Yes     | High temperature on blue DMD                                | Check if air slots are free.<br>Clean air filters.<br>If problem persists, call a qualified service engineer |
| 7685       | Blue front DMD temp open   | Yes   | Yes     | Temperature sensor on blue DMD not connected                | Call a qualified service engineer  |
| 7684       | Blue front DMD temp short  | Yes   | Yes     | Temperature sensor on blue DMD shorted                      | Call a qualified service engineer  |
| 7676       | Front block temp high      | Yes   | Yes     | High temperature on front DMD cooling block                 | Check if air slots are free.<br>Clean air filters.<br>If problem persists, call a qualified service engineer |
| 7675       | Front block temp open      | Yes   | Yes     | Temperature sensor on front cooling block not connected     | Call a qualified service engineer  |
| 7674       | Front block temp short     | Yes   | Yes     | Temperature sensor on front cooling block shorted           | Call a qualified service engineer  |
| 7672       | Red block temp high        | Yes   | Yes     | High temperature on red DMD cooling block                   | Check if air slots are free.<br>Clean air filters.<br>If problem persists, call a qualified service engineer |
| 7671       | Red block temp open        | Yes   | Yes     | Temperature sensor on red DMD cooling block not connected   | Call a qualified service engineer  |
| 7670       | Red block temp short       | Yes   | Yes     | Temperature sensor on red DMD cooling block shorted         | Call a qualified service engineer  |
| 7668       | Green block temp high      | Yes   | Yes     | High temperature on green DMD cooling block                 | Check if air slots are free.<br>Clean air filters.<br>If problem persists, call a qualified service engineer |
| 7667       | Green block temp open      | Yes   | Yes     | Temperature sensor on green DMD cooling block not connected | Call a qualified service engineer  |
| 7666       | Green block temp short     | Yes   | Yes     | Temperature sensor on green DMD cooling block shorted       | Call a qualified service engineer  |

21. Troubleshooting

| Error code | Description                   | Error | Warning | Caused by  | Action   |
|------------|-------------------------------|-------|---------|--|--|
| 7664       | Blue block temp high          | Yes   | Yes     | High temperature on blue DMD cooling block                 | Check if air slots are free.<br>Clean air filters.<br>If problem persists, call a qualified service engineer |
| 7663       | Blue block temp open          | Yes   | Yes     | Temperature sensor on blue DMD cooling block not connected | Call a qualified service engineer  |
| 7662       | Blue block temp short         | Yes   | Yes     | Temperature sensor on blue DMD cooling block shorted       | Call a qualified service engineer  |
| 7660       | Engine air temp high          | Yes   | Yes     | High temperature on engine                                 | Check if air slots are free.<br>Clean air filters.<br>If problem persists, call a qualified service engineer |
| 7659       | Engine air temp open          | Yes   | Yes     | Temperature sensor on engine not connected                 | Call a qualified service engineer  |
| 7658       | Engine air temp short         | Yes   | Yes     | Temperature sensor on engine shorted                       | Call a qualified service engineer  |
| 7999       | Fan speed cathode too low     | Yes   | Yes     | fan is running too slow or not at all                      | If problem persists, call a qualified service engineer   |
| 7998       | Fan speed cathode high        | -     | Yes     |  |  |
| 7997       | Fan speed anode too low       | Yes   | Yes     | fan is running too slow or not at all                      | If problem persists, call a qualified service engineer   |
| 7996       | Fan speed anode high          | -     | Yes     |  |  |
| 7995       | Fan speed engine too low      | Yes   | Yes     | fan is running too slow or not at all                      | If problem persists, call a qualified service engineer   |
| 7994       | Fan speed engine high         | -     | Yes     |  |  |
| 7993       | Fan speed cold mirror too low | Yes   | Yes     | fan is running too slow or not at all                      | If problem persists, call a qualified service engineer   |
| 7992       | Fan speed cold mirror high    |       |         |  |  |
| 7991       | Fan speed heat ex. too low    | Yes   | Yes     | fan is running too slow or not at all                      | If problem persists, call a qualified service engineer   |
| 7990       | Fan speed heat ex. high       | -     | Yes     |  |  |
| 7989       | Fan speed smps 1 too low      | Yes   | Yes     | fan is running too slow or not at all                      | If problem persists, call a qualified service engineer   |
| 7987       | Fan speed smps 2 too low      | Yes   | Yes     | fan is running too slow or not at all                      | If problem persists, call a qualified service engineer   |
| 7985       | Red DMD temp low              | No    | Yes     | low temperature on dmd                                     | turning on the lamp will heat up the dmd   |
| 7984       | Red DMD temp high             | Yes   | Yes     | high temperature on dmd                                    | check if air slot are free; clean air filters<br>If problem persists, call a qualified service engineer      |
| 7983       | Green DMD temp low            | No    | Yes     | low temperature on dmd                                     | turning on the lamp will heat up the dmd   |
| 7982       | Green DMD temp high           | Yes   | Yes     | high temperature on dmd                                    | check if air slot are free; clean air filters<br>If problem persists, call a qualified service engineer      |
| 7981       | Blue DMD temp low             | No    | Yes     | low temperature on dmd                                     | turning on the lamp will heat up the dmd   |

| Error code | Description        | Error | Warning | Caused by  | Action  |
|------------|--------------------|-------|---------|--|---|
| 7980       | Blue DMD temp high | Yes   | Yes     | high temperature on dmd  | check if air slot are free; clean air filters<br>If problem persists, call a qualified service engineer |
| 7978       | Lamp temp high     | Yes   | Yes     | high temperature lamp  | check if air slot are free; clean air filters<br>If problem persists, call a qualified service engineer |
| 7976       | SMPS HS temp high  | Yes   | Yes     | high temperature on smps                                       | check if air slot are free; clean air filters<br>If problem persists, call a qualified service engineer |
| 7974       | Ambient temp high  | Yes   | Yes     | ambient temperature above specification                        | check ambient conditions<br>check if air slot are free; clean air filters                               |
| 7973       | Fan 1 voltage low  | Yes   | Yes     | voltage on fan group 1 too low (= cathode fan)                 | Hardware problem in Fan control board, call a qualified service engineer                                |
| 7972       | Fan 1 voltage high | -     | Yes     | voltage on fan group 1 too high                                | Hardware problem in Fan control board, call a qualified service engineer                                |
| 7971       | Fan 2 voltage low  | Yes   | Yes     | voltage on fan group 2 too low (= anode fan)                   | Hardware problem in Fan control board, call a qualified service engineer                                |
| 7970       | Fan 2 voltage high | -     | Yes     | voltage on fan group 2 too high                                | Hardware problem in Fan control board, call a qualified service engineer                                |
| 7969       | Fan 3 voltage low  | Yes   | Yes     | voltage on fan group 3 too low (= engine fan)                  | Hardware problem in Fan control board, call a qualified service engineer                                |
| 7968       | Fan 3 voltage high | -     | Yes     | voltage on fan group 3 too high                                | Hardware problem in Fan control board, call a qualified service engineer                                |
| 7967       | Fan 4 voltage low  | Yes   | Yes     | voltage on fan group 4 too low (= cold mirror + head ex. fan)  | Hardware problem in Fan control board, call a qualified service engineer                                |
| 7966       | Fan 4 voltage high | -     | Yes     | voltage on fan group 4 too high (= cold mirror + head ex. fan) | Hardware problem in Fan control board, call a qualified service engineer                                |
| 7965       | Fan 5 voltage low  | Yes   | Yes     | voltage on fan group 5 too low (= mains input fan)             | Hardware problem in Fan control board, call a qualified service engineer                                |
| 7964       | Fan 5 voltage high | -     | Yes     | voltage on fan group 5 too high (mains input fan)              | Hardware problem in Fan control board, call a qualified service engineer                                |
| 7963       | Fan 6 voltage low  | Yes   | Yes     | voltage on fan group 6 too low (= smps fan)                    | Hardware problem in Fan control board, call a qualified service engineer                                |
| 7962       | Fan 6 voltage high | -     | Yes     | voltage on fan group 6 too low (= smps fan)                    | Hardware problem in Fan control board, call a qualified service engineer                                |
| 7959       | Pump voltage low   | Yes   | Yes     | voltage on pump too low  | If problem persists, call a qualified service engineer  |
| 7958       | Pump voltage high  | -     | Yes     | voltage on pump too high                                       | If problem persists, call a qualified service engineer  |
| 7957       | 30V voltage low    | No    | Yes     | supply voltage for fans too low                                | If problem persists, call a qualified service engineer  |
| 7956       | 30V voltage high   | No    | Yes     | supply voltage for fans too high                               | If problem persists, call a qualified service engineer  |
| 7955       | VTEC voltage low   | No    | Yes     | supply voltage for DMD cooling too low                         | If problem persists, call a qualified service engineer  |

## 21. Troubleshooting

| Error code | Description                   | Error | Warning | Caused by   | Action   |
|------------|-------------------------------|-------|---------|---|--|
| 7954       | VTEC voltage high             | No    | Yes     | supply voltage for DMD cooling too high             | If problem persists, call a qualified service engineer   |
| 7953       | VMTR voltage low              | No    | Yes     | supply voltage for motors too low                   | If problem persists, call a qualified service engineer   |
| 7952       | VMTR voltage high             | No    | Yes     | supply voltage for motors too high                  | If problem persists, call a qualified service engineer   |
| 7945       | 5V voltage low                | No    | Yes     | supply voltage for electronics too low              | If problem persists, call a qualified service engineer   |
| 7944       | 5V voltage high               | No    | Yes     | supply voltage for electronics too high             | If problem persists, call a qualified service engineer   |
| 7943       | 5V FIB voltage low            | No    | Yes     | supply voltage for engine electronics too low       | If problem persists, call a qualified service engineer   |
| 7942       | 5V FIB voltage high           | No    | Yes     | supply voltage for engine electronics too high      | If problem persists, call a qualified service engineer   |
| 7941       | 5V PMP voltage low            | No    | Yes     | supply voltage for drawer electronics too low       | If problem persists, call a qualified service engineer   |
| 7940       | 5V PMP voltage high           | No    | Yes     | supply voltage for drawer electronics too high      | If problem persists, call a qualified service engineer   |
| 7939       | Prism                         | No    | Yes     | projection lens too close to prism                  | move lens away from prism (up and/or right)  |
| 7938       | Lamp not inserted well        | Yes   | No      | lamp module not correctly inserted                  | reinsert lamp module and screw firmly  |
| 7937       | Waterflow                     | Yes   | No      | bad or no water flow in cooling circuit             | If problem persists, call a qualified service engineer   |
| 7936       | Tilt                          | No    | Yes     | tilt angle is out of specifications                 | Correct projection installation.<br>Change the tilting so that the tilt angle becomes within the specifications. |
| 7935       | Engine not well inserted      | Yes   | No      | engine is not correctly inserted                    | If problem persists, call a qualified service engineer   |
| 7934       | FIB not inserted well         | Yes   | No      | formatter interface board is not correctly inserted | If problem persists, call a qualified service engineer   |
| 7931       | PFC HS high temp              | Yes   | Yes     | high temperature on smps                            | check if air slot are free; clean air filters<br>If problem persists, call a qualified service engineer          |
| 7929       | SMPS HS high temp             | Yes   | Yes     | high temperature on smps                            | check if air slot are free; clean air filters<br>If problem persists, call a qualified service engineer          |
| 7928       | Overtemp                      | Yes   | No      | extreme overheating of dmd's or lamp                | If problem persists, call a qualified service engineer   |
| 7927       | fan speed mains input too low | Yes   | Yes     | fan is not running or is running too slow           | If problem persists, call a qualified service engineer   |
| 7926       | fan speed mains input high    | -     | Yes     |   |  |
| 8000       | Opening shutter failed        | No    | Yes     |   | If problem persists, call a qualified service engineer   |
| 8001       | Closing shutter failed        | No    | Yes     |   | If problem persists, call a qualified service engineer   |
| 8002       | Lamp EEPROM                   | No    | Yes     |   | If problem persists, call a qualified service engineer   |
| 9000       | Scaler unit failed            | Yes   | -       | Initialization of the scaler failed                 | If problem persists, call a qualified service engineer   |
| 9198       | Scaler pixel clock too high   | Yes   | -       | BW or refresh rate of input source too high         |  |



---

| <b>Error code</b> | <b>Description</b>          | <b>Error</b> | <b>Warning</b> | <b>Caused by</b>                             | <b>Action</b>                     |
|-------------------|-----------------------------|--------------|----------------|--|-----------------------------------|
| 9398              | Maximum image files reached | Yes          | No             | Reaching the maximum allowed number of files | Delete some unnecessary files     |
| 10498             | Unsupported module          | Yes          | No             | Module with obsolete firmware                | Call a qualified service engineer |



---

## 22. SPECIFICATIONS

### Overview

- Specifications FLM HD20
- Specifications FLM 5 cable input (multi purpose)
- Specifications FLM HDSDI – SDI input
- Specifications FLM DVI input
- Specifications FLM DVI HDCP input

### 22.1 Specifications FLM HD20

---

#### Overview

##### Light Output

20,000 Center lumens

##### Resolution

1,920 x 1,080 (native)

##### Contrast ratio

1800 : 1 (full field)

high contrast mode:

2400 : 1 (full field)

##### Lamp

3.5 kW Xenon

Warranty universal lamphouse: 750 Hrs

##### Power consumption

4200 W

##### Mains Voltage

200 - 240 V

##### Weight

99 kg (220 lbs)

##### Dimensions

WxLxH:

707 x 1025 x 548 mm

(27.8 x 40.3 x 21.5 inch)

incl. carrying handle + rigging points

##### ScenergiX

Standard horizontal & vertical electronic edge blending

##### Network connection

10/100 base-T

##### Picture-in-picture

2 sources simultaneously

### Ambient Temperature

Max 40°C (104°F)

### Inputs

- configurable 5 cable (BNC)
- DVI
- (HD)SDI (+ loop through)

### Input source compatibility

max. input: up to QXGA (2048 x 1536)

### Dust filters

Dense, high quality microfilters, also available as spare kit

### Brightness uniformity

> 90 % for the total screen

### Display

3-chip DLP HD (1920 x 1080 pixels, aspect ratio 16:9)

### Lens Shift

Vertical: -10% to +110%

Horizontal: -30% to +30%

(small differences exist per lens type, e.g. short throw lenses have less shift)

### On board display server

Ethernet control standard

remote control projector over ethernet via Projector Toolset

### Outputs

HDSDI/ SDI loop out

### Communication

- 1x RS-232C IN (D-9 connector)
- 1x RS-232C OUT (D-9 connector)
- 1x RS-232C IN (XLR connector)
- 2x prop. protocol (RJ45 connector)
- xlr and mini-jack for wired remote control

### Compatibility

- All current video sources (PAL, SECAM, NTSC) in Composite, S-Video, Component or RGB formats
- All current HDTV sources
- All computer graphics formats from VGA, SVGA, XGA, SXGA, full HD, UXGA to QXGA
- Most Macintosh computers
- Electronic workstations with a resolution up to QXGA (2048 x 1536 pixels @ 60 Hz)
- Most computer sources with a pixel clock up to 300 MHz
- DVI sources up to DC2K (2048 x 1080)

### Power Dissipation

max 13,300BTU/h

**Features**

- Picture-in-picture
- Seamless switching with effects
- Standard light shutter
- Rigging points
- Carrying handle
- High contrast mode
- P7 color processing

**Screen size**

From 1 - 12m / 3 - 39ft. recommended

**Scan Frequencies**

pixel clock >162Mhz (up to QXGA @ 60Hz)

**Lens encoders**

On zoom and focus (with TLD lenses)

**Safety Regulations**

Compliant with UL1950 and EN60950

**Electromagnetic Interference**

complies with FCC rules & regulations, part 15 Class A and CE EN55022 Class A

**Throw Ratio**

| Lens               | Throw ratio |
|--------------------|-------------|
| TLD (HB) 0.8       | 0.75        |
| TLD (HB) 1.2       | 1.1         |
| TLD (HB) 1.2+      | 1.23        |
| TLD (HB) 1.6 - 2.0 | 1.45 - 1.85 |
| TLD (HB) 2.0 - 2.8 | 1.85 - 2.55 |
| TLD (HB) 2.8 - 5.0 | 2.55 - 4.55 |
| TLD (HB) 5.0 - 8.0 | 4.55 - 7.3  |

**Noise Level**

58 dBA (at 40°C)

**Order Information**

Projector: R9004510  
 Spare lamp: R9854540  
 6-pack dust filters: R9454470  
 24-pack dust filters: R9454480  
 RGB HV module: R9854440  
 FLM/SLM adaptor plate: R9854490  
 FLM carry handle: R9854530  
 FLM flight case: R9854510

**Lenses**

| Lens         | Order nr |
|--------------|----------|
| TLD (HB) 0.8 | R9842040 |
| TLD (HB) 1.2 | R9840770 |

## 22. Specifications

|                    |          |
|--------------------|----------|
| TLD (HB) 1.2+      | R9840775 |
| TLD (HB) 1.6 - 2.0 | R9842060 |
| TLD (HB) 2.0 - 2.8 | R9842080 |
| TLD (HB) 2.8 - 5.0 | R9842100 |
| TLD (HB) 5.0 - 8.0 | R9842120 |

### Convergence

Max allowed convergence drift is 0.5 pixel.

This is checked on vertical and horizontal midlines only.

Corners are not applicable for convergence error.

This is measure with TLD 1.2 lens on axis.

### Shipping Dimensions

Width: 92 cm

Height: 95 cm

Depth: 123 cm

Floor Space: 1,1316 m<sup>2</sup>

Volume: 1,075020 m<sup>3</sup>

Gross Weight: 161 kg

## 22.2 Specifications FLM 5 cable input (multi purpose)

### Front view 5 cable input

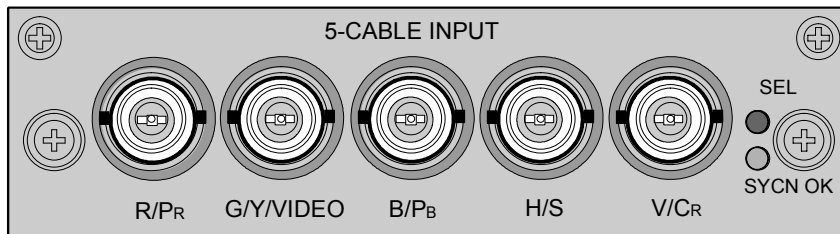

Image 22-1

### Signal connectivity

| Input signal             | R / P <sub>R</sub>       | G / Y / VIDEO       | B / P <sub>B</sub>       | H / S                              | V / C <sub>R</sub> |
|--------------------------|--------------------------|---------------------|--------------------------|------------------------------------|--------------------|
| RGBHV                    | R                        | G                   | B                        | H                                  | V                  |
| RGBS                     | R                        | G                   | B                        | S                                  | —                  |
|                          |                          |                     |                          | composite sync or VIDEO<br>as sync |                    |
| RGsB                     | R                        | Gs<br>sync on green | B                        | —                                  | —                  |
| Composite Video          | —                        | VIDEO               | —                        | —                                  | —                  |
| Super Video              | —                        | Y                   | —                        | —                                  | C                  |
|                          |                          | Luma                |                          |                                    | Chroma             |
| Component Video<br>- SS  | P <sub>R</sub> / (R - Y) | Y                   | P <sub>B</sub> / (B - Y) | S                                  | —                  |
|                          |                          |                     |                          | composite sync or VIDEO<br>as sync |                    |
| Component Video<br>- SOY | P <sub>R</sub> / (R - Y) | Ys                  | P <sub>B</sub> / (B - Y) | —                                  | —                  |

## Specifications

- Data and HD sources RGB and YUV [HS/VS, CS or SOG(Y)]:
  - Pixel clock maximum 275 MHz
  - 8 bit digital output
- Video sources CVBS, S-VIDEO, RGB and YUV [CS, CV or SOG(Y)]:
  - PAL B/D/I/G/H, PAL60, PAL M, PAL N, PAL Nc
  - NTSC M/J, NTSC 4.43
  - SECAM B/D/G/K/L
  - 525i, 625i, 525p, 625p
  - Macrovision copy protection robust
  - 10 bit digital output
  - Standard images "video525" and "video625"
- Automatic detection of sync inputs but with manual override:
  - automatic modes : RGB, YUV, VIDEO
  - manual modes : RGB HS/VS - CS, RGB CV, RGB SOG, YUV HS/VS - CS, YUV CV, YUV SOY, CVBS, S-VIDEO
- Possible to disconnect 75 Ohm terminations on HS and VS (TTL sync level selection)
- Signal requirements:
  - Component Video (BNC)
    - o R-Y : 0,7Vpp  $\pm$ 3dB 75 Ohm termination.
    - o Ys : 1Vpp  $\pm$ 3dB (0,7V Luma +0,3V Sync) 75 Ohm termination.
    - o B-Y : 0,7Vpp  $\pm$ 3dB 75 Ohm termination.
  - RG(s)B
    - o R : 0,7Vpp  $\pm$ 3dB 75 Ohm termination.
    - o G(s) : 1Vpp  $\pm$ 3dB (0,7Vpp G + 0,3Vpp Sync) 75 Ohm termination.
    - o B : 0,7Vpp  $\pm$ 3dB 75 Ohm termination.
- Diagnostic LED's on front panel:
  - Green LED: Lights up in case input module is selected
  - Yellow LED: Lights up in case sync detected

## 22.3 Specifications FLM HDSDI – SDI input

### Input front view HDSDI – SDI input

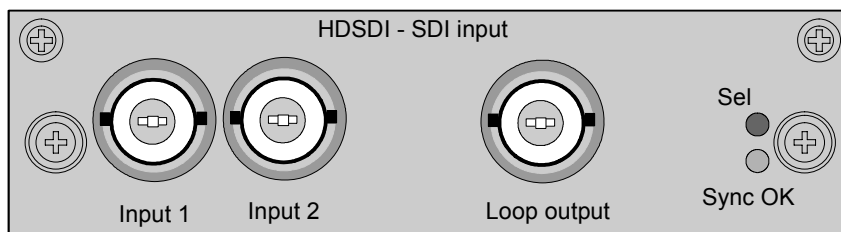

Image 22-2

### Specifications

- SD SMPTE 259M-C and HD SMPTE 292M input data
- 2 inputs (BNC), 1 active loop-through output (BNC) of selected input
- Automatic selection of active input with manual override
- 10 bit digital output
- Diagnostic LED's on front panel:
  - Green LED: Lights up in case input module is selected
  - Yellow LED: Lights up in case sync detected
- SDI: 270 Mbit/s transmission (SMPTE 259M-C).
- SDI: 525/625 interlaced.
- Coax (75 Ohm).

- Supported HDSI standards:
  - Progressive:
    - 1280x720/60/1:1/ (SMPTE 296M)
    - 1280x720/59.94/1:1/ (SMPTE 296M)
    - 1920x1080/30/1:1/ (SMPTE 274M)
    - 1920x1080/29.97/1:1/ (SMPTE 274M)
    - 1920x1080/25/1:1/ (SMPTE 274M)
    - 1920x1080/24/1:1/ (SMPTE 274M)
    - 1920x1080/23.98/1:1/ (SMPTE 274M)
  - Interlaced:
    - 1920x1035/60/2:1/ (SMPTE 260M)
    - 1920x1035/59.94/2:1/ (SMPTE 260M)
    - 1920x1080/60/2:1/ (SMPTE 274M)
    - 1920x1080/59.94/2:1/ (SMPTE 274M)
    - 1920x1080/50/2:1/ (SMPTE 274M)
    - 1920/1080/50/2:1 (1250)/ (SMPTE 295M)
    - 1920x1080/24/Segmented/ (SMPTE 274M)
    - 1920x1080//23.98/Segmented/ (SMPTE 274M)

### 22.4 Specifications FLM DVI input

---

#### Input front view

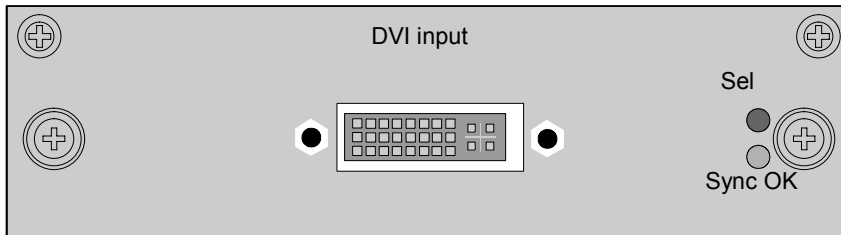

Image 22-3

#### Specifications

- DVI type: DVI-I (DVI-Integrated), but the analog signals are not supported. Single-link configuration.
- Single link dvi for pixelclocks up to 165MHz
- Vertical frequencies: 24 - 75 Hz
- Horizontal frequencies: 20 - 90 kHz
- Supported resolutions: up to UXGA (1600 x 1200) at 60 Hz.
- Cable lengths: up to 3 meter at UXGA speed.
- Compliance: DDC2B support according to VESA EDID Version 1.2
- Diagnostic LED's on front panel:
  - Green LED: Lights up in case input module is selected
  - Yellow LED: Lights up in case sync detected



## 22.5 Specifications FLM DVI HDCP input

### Input front view

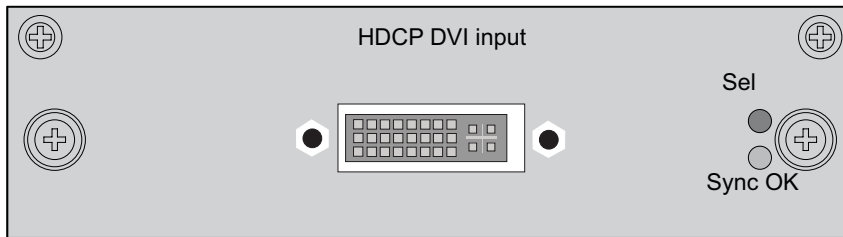

Image 22-4

### Specifications

- DVI type: DVI-I (DVI-Integrated), but the analog signals are not supported. Single-link configuration.
- Supports UXGA Resolution (1600 x 1200) (Output Pixel Rates up to 165 MHz)
- True-Color, 24 Bits/Pixel, 48-Bit Dual Pixel Output Mode, 16.7M Colors at 1 or 2 Pixels Per Clock
- Digital Visual Interface (DVI) and High-Bandwidth Digital Content Protection (HDCP) Specification Compliant
- Vertical frequencies: 24 - 75 Hz
- Horizontal frequencies: 20 - 90 kHz
- Cable lengths: up to 3 meter at UXGA speed.
- Compliance: DDC2B support according to VESA EDID Version 1.2
- Diagnostic LED's on front panel:
  - Green LED: Lights up in case input module is selected
  - Yellow LED: Lights up in case sync detected



## 23. ORDER INFORMATION

### 23.1 Spare part order info

#### Order info:

| Order info | Description  |
|------------|--|
| R9854490   | FLM/SLM adaptor plate (for stacking an SLM projector upon an FLM projector). |
| R9854420   | FLM lamp house (3kW lamp included).  |
| R9854520   | FLM lamp house refurbish (3kW lamp included).                                |
| R9854430   | 5 Cable input module.  |
| R9854440   | High bandwidth data input module (RGB).                                      |
| R9854450   | HDSDI - SDI input module.  |
| R9854460   | DVI input module.  |
| R9854465   | DVI HDCP input module  |
| R848607    | Cover plate for unused input slot.   |
| R9854470   | FLM front, top and bottom filters (6 pieces each).                           |
| R9854480   | FLM front, top and bottom filters (24 pieces each).                          |
| R9854510   | FLM flight case.   |
| R764988    | FLM remote control unit (RCU)  |
| R820411    | One rigging clamp for truss installations.                                   |
| Z3499178   | FLM power cord.  |
| R9842040   | TLD HB fixed lens (0.8 : 1)  |
| R9840770   | TLD HB fixed lens (1.2 : 1)  |
| R9840775   | TLD HB fixed lens (1.2+ : 1)   |
| R9842060   | TLD HB zoom lens (1.6 - 2.0 : 1)   |
| R9842080   | TLD HB zoom lens (2.0 - 2.8 : 1)   |
| R9842100   | TLD HB zoom lens (2.8 - 5.0 : 1)   |
| R9842120   | TLD HB zoom lens (5.0 - 8.0 : 1)   |



---

# GLOSSARY

**2:2 pull-down**

The process of transferring 24-frames/sec film format into video by repeating each frame (used for PAL DVD's) as two video fields. ( AD )

**3:2 pull-down**

Method used to map the 24 fps of film onto the 30 fps (60 fields) or 25 fps (50 fields), so that one film frame occupies three video fields, the next two, etc. It means the two fields of every other video frame come from different film frames making operations such as rotoscoping impossible, and requiring care in editing. Some sophisticated equipment can unravel the 3:2 sequence to allow frame-by-frame treatment and subsequently re-compose 3:2. The 3:2 sequence repeats every five video frames and four film frames, the latter identified as A-D. Only film frame A is fully on a video frame and so exists at one time code only, making it the editable point of the video sequence.

**Art-Net DMX**

DMX protocol over an Ethernet network.

**Artefacts**

Undesirable elements or defects in a video picture. These may occur naturally in the video process and must be eliminated in order to achieve a high-quality picture. Most common in analog are cross color and cross luminance. Most common in digital are macroblocks, which resemble pixelation of the video image.

**Aspect ratio**

Relation between the horizontal & vertical dimension in which the window will be displayed, e.g. 4 by 3 or 16 by 9. Can also be expressed as a decimal number, such as 1.77. The larger the ratio or decimal, the wider are less square the image.

**Color space**

A color space or color standard is a mathematical representation for a color. For example the RGB color space is based on a Cartesian coordinate system.

**Color temperature**

The coloration (reddish, white, bluish, greenish, etc.) of white in an image, measured using the Kelvin (degrees K) temperature scale. Higher temperatures output more light.

**Common address**

Projector will always execute the command coming from a RCU programmed with that common address.

**Default Gateway**

A router that serves as an entry point into and exit point out of a network. For example, a local network (LAN) may need a gateway to connect it to a wide area network (WAN) or to the Internet.

**DHCP**

Dynamic host configuration protocol. DHCP is a communications protocol that lets network administrators manage centrally and automate the assignment of IP addresses in an organization's network. Using the Internet Protocol, each machine that can connect to the Internet needs a unique IP address. When an organization sets up its computer users with a connection to the Internet, an IP address must be assigned to each machine. Without DHCP, the IP address must be entered manually at each computer and, if computers move to another location in another part of the network, a new IP address must be entered. DHCP lets a network administrator supervise and distribute IP addresses from a central point and automatically sends a new IP address when a computer is plugged into a different place in the network.

**DMX**

DMX-512 Lighting protocol, here used over Ethernet. Carries information of 512 channels from a lighting controller to lighting devices. Standardized by USITT.

**Gamma**

"Gamma" is a global setting that determines what gray shades are displayed between minimum input (black) and maximum input (white) for all signals. A good gamma setting helps to optimize blacks and whites while ensuring smooth transitions for the "in-between" values utilized in other colors. Thus, unlike "Brightness" and "Contrast" controls, the overall tone of your images can be lightened or darkened without changing the extremes, and all images will be more vibrant while still showing good detail in dark areas.

**HDCP**

High-bandwidth Digital Content Protection (HDCP) is a form of digital copy protection developed by Intel Corporation to protect digital audio and video content as it travels across DisplayPort, Digital Visual Interface (DVI), High-Definition Multimedia Interface (HDMI), Gigabit Video Interface (GVIF), or Unified Display Interface (UDI) connections. The specification is proprietary, and implementing HDCP requires a license.

**HEPA**

High Efficiency Particulate Absorbing

**IP**

Internet Protocol. The network layer of TCP/IP. Required for communication with the internet.

**MAC address**

Media Access Control address. Unique hardware number, used in combination with the IP-address to connect to the network (LAN or WAN).

**PiP**

PiP stands for "Picture in Picture" and allows to display multiple windows containing each of them an image. The windows may be of the video or data type.

**Projector address**

Address installed in the projector to be individually controlled.

**Restricted access location**

A location for equipment where both of the following paragraphs apply:

- 1) Access can only be gained by SERVICE PERSONS or by USERS who have been instructed about the reasons for the restriction applied to the location and about the precautions that shall be taken.
- 2) Access is through the use of the tool or lock and key, or other means of security, and is controlled by the authority responsible for the location.

**RS232**

An Electronic Industries Association (EIA) serial digital interface standard specifying the characteristics of the communication path between two devices using either D-SUB 9 pins or D-SUB 25 pins connectors. This standard is used for relatively short-range communications and does not specify balanced control lines. RS-232 is a serial control standard with a set number of conductors, data rate, word length and type of connector to be used. The standard specifies component connection standards with regard to computer interface. It is also called RS-232-C, which is the third version of the RS-232 standard, and is functionally identical to the CCITT V.24 standard. Logical '0' is  $> +3V$ , Logical '1' is  $< -3V$ . The range between  $-3V$  and  $+3V$  is the transition zone.

**RS422**

An EIA serial digital interface standard that specifies the electrical characteristics of balanced (differential) voltage, digital interface circuits. This standard is usable over longer distances than RS-232. This signal governs the asynchronous transmission of computer data at speeds of up to 920,000 bits per second. It is also used as the serial port standard for Macintosh computers. When the difference between the 2 lines is  $< -0.2V$  that equals with a logical '0'. When the difference is  $> +0.2V$  that equals to a logical '1'.

**Subnet mask**

A number that is used to identify a subnetwork so that IP addresses can be shared on a local area network.

# INDEX

## A

- Address 52
  - Program 52
  - RCU 52
- Adjustment 49–50
  - Quick set up 49–50
    - Lens 49
    - Lens functions 50
    - Lens key 49
    - PIP 50
- Adjustment mode 55–57
- About 55
  - LCD display menus 56
  - Local keypad 55
  - Menu memory 57
  - Navigation 56
  - On screen menus 56
  - RCU 55
  - Start up 55
  - Test patterns 57
- Air flow 18
- Align 27, 33
  - Ceiling mount 27
  - Stacked 33
  - Table mount 27
- Alignment 115–128, 130–135, 137, 139, 143
  - Blanking 128
  - Color space 131
  - Color standard 131
  - Contrast enhancement 128
  - Gamma 130
  - Internal pattern 130
  - Lens 117
    - Focus 117
    - Mid position 117
    - Shift 117
    - Zoom 117
  - Lens adjustment 117
  - Orientation 116
  - Overview flow 115, 143
  - ScenergiX 132–135, 137, 139
    - Activation 133
    - Black level 139
    - Horizontal overlap 134
    - Introduction 132
    - Preparations 133
    - Size adjustment 137
    - Vertical overlap 135
    - White level 137
  - Side keystone 118
  - Warp 119–127
    - 4 corners 125
    - About 119
    - Barrel correction 124
    - Horizontal keystone 121
    - Load warp file 127
    - Pincushion correction 124
    - Reset 126
    - Rotation 123
    - Status 120
    - Vertical keystone 122
- Art-Net activation 155
- Art-Net DMX 151–155
  - Art-Net activation 155
  - DMX address 152
  - DMX mode 154
  - DMX monitor 153
  - DMX universe 152
  - Home lens at startup 155
- Aspect ratio 82
  - Custom 82

## B

- Background color 66
  - No signal 66
- Blanking 128
- Box content 13
- Brightness 71
- Broadcast mode 175
- Buttons 156–157
  - APA 157
  - Auto 157
  - Shortcut keys 157
  - Standby 156

## C

- Card bus 41
- Ceiling mount 27
  - Align 27
- cleaning 182
  - lens 182
- Cleaning 182
  - Exterior 182
- Color saturation 72
- Color space 131
- Color standard 131
- Color temperature 76–77
  - Custom values 77
  - Predefined values 76
- Communication 38
  - Connection 38
- Configurations 14–15
  - Front projection 14
  - Rear projection 15
- Connection 35, 37–38
  - Communication 38
  - Power 35
  - Source 37
- Connections 35, 47
  - Switching off 47
- Contrast 71
- Contrast enhancement 128
- Convergence 170
  - Service patterns 170
- Cooling circuit 181
  - Pressure 181
- Cooling liquid circuit warning 7
- Copy 108
  - Layout 108
- Cover 191
  - Removal 191
- Custom aspect ratio 82
- Custom color temperature 77

## D

- Delete 107
  - Layout 107
- Diagnosis 165, 167–169
  - Fan speeds 168
  - SPI 169
  - Start up 165, 167
  - Temperatures 167
- Dimensions 199–201
  - Flight case 200
  - Projector 199
  - Rigging clamps 201
- DMX address 152
- DMX chart 205–207
  - Basic 205
  - Extended 206
  - Full 207
- DMX mode 154

- DMX monitor 153
- DMX universe 152
- Download plug-in 18
- Download Projector Toolset 18
- Dust filter 179–181
  - Bottom 180
  - Front 179
  - Top 181
  
- E**
- Error codes 211
- Error logging 170
  - Start up 170
- Ethernet 40
- Exterior 182
  - Cleaning 182
  
- F**
- Fan speeds 168
  - Diagnosis 168
- File services 88
  - Manual load file 88
- Film mode detection 86
- Flight case 14
- Front projection 14
- Fuses 36
  
- G**
- Gamma 130
- General 18
  - Download plug-in 18
  - Download Projector Toolset 18
- General info 11
- Getting started 43, 45, 49, 52–53
  - Operating 45
  - Projector address 52
  - Quick setup 49
  - Source selection 53
  - Terminology overview 43
- Getting Started 43, 45, 47, 54
  - Controlling the projector 54
  - RCU & local keypad 43
  - Switching on 45
  - Using the RCU 47
  
- H**
- Hang up 28
  - Projector 28
- Hue 73
  
- I**
- Identification 113
  - Lamp 113
- Image 69–76, 78–79, 82–84, 86–92
  - Advanced settings 84, 86
    - Clamp delay 84
    - Clamp width 84
    - Field polarity 84
    - Film mode detection 86
  - Aspect ratio 82
  - File services 88
    - Manual load file 88
  - Film mode detection 86
  - Image file services 87
  - Image services 87, 89–91
    - Copy file 91
    - Delete file 89
    - File manipulations 87
    - File options 91
  - Files 87
    - Rename file 90
  - Image settings 70–76, 78–79
    - Brightness 71
    - Color saturation 72
    - Color temperature 76
    - Contrast 71
    - Hue 73
    - Input balance 78
    - Input balance adjusting 79
    - Noise reduction 75
    - Phase 73
    - Saturation 72
    - Sharpness 74
    - Tint 73
  - Overview flow 69
  - Save custom settings 92
  - Source timings 83
  - Start up 70
  - Timings 83–84
    - Advanced settings 84
  - Image file services 87
  - Image files 203
    - standard 203
  - Image services 87, 89–92
    - Copy file 91
    - Delete file 89
    - File manipulations 87
    - File options 91
    - Files 87
      - Rename file 90
      - Save custom settings 92
    - Infra red 38
    - Input 59–61, 63, 65–66
      - Configuration 60
      - Input locking 61
      - Minimum delay 63
      - Module type 59
      - Native resolution 63
      - No signal 65–66
        - Background color 66
        - Shutdown 66
        - Shutdown retarding time 66
      - Overview flow 59
      - Slot module type 59
      - Source switching 65
    - Input & communication unit 184, 187
      - Install 187
      - Remove 184
    - Input balance 78–81
      - Adjusting 79
      - Black balance 80
      - Introduction 78
      - White balance 81
    - Input module 185, 188
      - Install 188
      - Remove 185
    - Input setup 59
      - About 59
    - Install 186–188, 194–197
      - Front cover 194
      - Input & communication unit 187
      - Input cover 197
      - Input module 188
      - Lamp cover 196
      - Lamp house 186
      - Side cover 195
    - Installation 11, 19
      - Requirements 11
    - Installation requirements 11–12
      - Ambient temperature 11
      - Clean air 11
      - Humidity 11
      - Image size 12
      - Projector weight 11
      - Screen type 11



Internal pattern 130  
 Selection 130  
 IR communication 38  
 IR control 151

**K**

Keystone 118

**L**

Lamp 111–113, 189  
 Identification 113  
 Overview flow 111  
 Power 112  
 Power mode 111  
 Realign 189  
 Z-axis 113  
 Lamp house 183, 186  
 Install 186  
 Remove 183  
 Lamp identification 113  
 Lamp power 112  
 Lamp power mode 111  
 Language 51, 160  
 Selection 51, 160  
 Laser Beams 8  
 Layout 95–96, 99, 101–102, 105–109  
 Copy 108  
 Delete 107  
 Layout file services 106  
 Layout services 106–108  
 Copy 108  
 Delete 107  
 Load 106  
 Rename 107  
 Save as 108  
 Load 106  
 Main window 95–96, 99  
 Position 99  
 Size 96  
 Source 96  
 Overview flow 95  
 PIP 101–102, 105  
 Activation 101  
 Position 105  
 Size 102  
 Source 101  
 Rename 107  
 Save as 108  
 Zoom - Focus 109  
 LCD display menus 56  
 lens 182  
 cleaning 182  
 Lens 23–24, 26, 117  
 Available 23  
 Focus 117  
 Formulas 24  
 Install 24  
 Mid position 117  
 Removal 26  
 Selection 23  
 Shift 117  
 Zoom 117  
 Lens adjustment 117  
 Lenses 23  
 Load 106  
 Layout 106

**M**

Maintenance 179  
 Menu memory 57  
 Menu position 158–159  
 Bar scale 159

On screen menu 158  
 Minimum delay 63

**N**

Native resolution 63  
 Navigation 56  
 Adjustment mode 56  
 Network 147–150  
 DHCP 148  
 Gateway 150  
 Introduction 148  
 IP-address 149  
 Subnet-mask 149  
 No signal 65–66  
 Background color 66  
 Shutdown 66  
 Shutdown retarding time 66  
 Noise reduction 75  
 Notice on safety 5

**O**

Off-Axis 16  
 On screen menus 56  
 On-Axis 16  
 Order information 227  
 Orientations 14–15  
 Front projection 14  
 Rear projection 15

**P**

PCMCIA 41  
 Phase 73  
 Physical installation 23  
 Lenses 23  
 PIP 100–102, 105  
 Activation 101  
 Introduction 100  
 Position 105  
 Size 102  
 Source 101  
 Position 99  
 Main window 99  
 Positioning 16  
 Power 35  
 Connection 35  
 Preset color temperature 76  
 Pressure 181  
 Cooling circuit 181  
 Prevent 6–8, 20  
 Battery explosion 8, 20  
 Device damage 7  
 Electrical shock 6  
 Fire hazard 8  
 Personal injury 7  
 Projector 14, 16–18  
 Air inlets 18  
 Air outlets 18  
 Configurations 14  
 Orientations 14  
 Positioning 16  
 Shift range 16  
 Tilt range 17  
 Projector address 52–53, 144–145  
 Address 144  
 Common address 145  
 Controlling 53  
 Projector control 143–160  
 Art-Net DMX 151–155  
 Art-Net activation 155  
 DMX address 152  
 DMX mode 154  
 DMX monitor 153

- DMX universe 152
- Home lens at startup 155
- Buttons 156–157
  - APA 157
  - Auto 157
  - Shortcut keys 157
  - Standby 156
- IR control 151
- Language 160
  - Selection 160
- Local LCD 159
- Local LCD contrast 160
- Local LCD time out 159
- Menu position 158–159
  - Bar scale 159
  - On screen menu 158
- Network 147–150
  - DHCP 148
  - Gateway 150
  - Introduction 148
  - IP-address 149
  - Subnet-mask 149
- Projector address 144–145
  - Address 144
  - Common address 145
- Serial communication 146–147
  - Baud rate setup 146
  - Interface standard 146
  - RS422 termination 147
- Projector status 38

## Q

- Quick language 51
  - Selection 51
- Quick layout 51
  - Rigging key 51
  - Selection 51
- Quick set up 49–50
  - Lens 49–50
    - Lens functions 50
    - LENS key 49
  - PIP 50
  - Text on/off 49
- Quick setup 19

## R

- RCU 19, 21–22
  - Possibilities 22
  - Rugged case 21
  - XLR adaptor 21
- Realign 189
  - Lamp 189
- Rear projection 15
- Refill mode 174
- Remote control 19–20, 38
  - Battery 20
- Remote Control 50
  - Lens functions 50
  - PIP 50
- Remove 183–185, 191–193
  - Front cover 191
  - Input & communication unit 184
  - Input module 185
  - Lamp cover 193
  - Lamp house 183
  - Side cover 192
- Rename 107
  - Layout 107
- Replace 179–181
  - Dust filter 179–181
    - Bottom 180
    - Front 179
    - Top 181

- Reset formatter 173
- Restore factory defaults 172
- Rigging clamps 28
- Rigging key 51
  - Quick layout selection 51
- Rigging points 28
- RS232 39
- RS422 39

## S

- Safety 5–9, 20
  - Battery explosion 20
  - Cooling liquid circuit 7
  - Device damage 7
  - Electrical shock 6
  - Fire hazard 8
  - Flight cases 9
  - General 5
  - Important instructions 6
  - Personal injury 7
  - Replacement parts 8
  - Servicing 8
- Saturation 72
- Save as 108
  - Layout 108
- Save custom settings 174
- ScenergiX 132–135, 137, 139
  - Activation 133
  - Black level 139
  - Horizontal overlap 134
  - Introduction 132
  - Preparations 133
  - Size adjustment 137
  - Vertical overlap 135
  - White level 137
- Serial communication 39, 146–147
  - Baud rate setup 146
  - Interface standard 146
  - RS422 termination 147
- Service 163, 165–176
  - Broadcast mode 175
  - Convergence 170
  - Diagnosis 165, 167–169
    - Fan speeds 168
    - SPI 169
    - Start up 165, 167
    - Temperatures 167
  - Error logging 170
    - Start up 170
  - Identification 163
  - Internal service patterns 171
  - Overview flow 163
  - Refill mode 174
  - Reset formatter 173
  - Restore factory defaults 172
  - Save custom settings 174
  - USB memory 176
  - Versions 165
    - Start up 165
  - Voltages 166
    - Start up 166
- Service patterns 171
  - Internal patterns 171
- Servicing 183
- Sharpness 74
- Shift range 16
- Shutdown, automatic 66
  - No signal 66
  - Retarding time 66
- Side keystone 118
- Size 96
  - Main window 96
- Source 37
  - Connection 37
- Source files 203

- Source selection 53
- Source switching 65
- Source timings 83
- Spare parts 227
- Spare power plug 36
- Specifications 219, 222–225
  - 5 cable input 222
  - DVI HDCP 225
  - DVI input 224
  - FLM HD20 219
  - HDSI–SDI input 223
- SPI 169
  - Diagnosis 169
- Stacked 33
  - Align 33
- Stacking 31
- Start up 46, 55
  - Adjustment mode 55
  - Errors and warnings 46
- Startup errors 46
- Startup warnings 46
- Suspend 28
  - Projector 28
- Switching off 47
- Switching to standby 46

## T

- Table mount 27
  - Align 27
- Temperatures 167
  - Diagnosis 167
- Test patterns 57
  - Adjustment mode 57
- Text on/off 49
- Tilt range 17
- Timings 83
- Tint 73
- Troubleshooting 211
  - Error codes 211

## U

- Unpacking 12
- USB memory 176
- USB port 41

## V

- Versions 165
  - Start up 165
- Volt meter 36
- Voltages 166
  - Start up 166

## W

- Warnings 7
  - Cooling liquid circuit 7
- Warp geometry settings 119–127
  - 4 corners 125
  - About 119
  - Barrel correction 124
  - Horizontal keystone 121
  - Load warp file 127
  - Pincushion correction 124
  - Reset 126
  - Rotation 123
  - Vertical keystone 122
  - Warp status 120
- Window 95, 100
  - PIP window 100

## Z

- Z-axis 113
  - Lamp 113
- Z-axis adjustment 113
- Zoom - Focus 109
  - Layout 109



## Revision Sheet

To:

► **Barco nv Media & Entertainment Division/Documentation**  
Noordlaan 5, B-8520 Kuurne  
Phone: +32 56.36.82.11, Fax: +32 56.36.88.24  
E-mail: [service.mne@barco.com](mailto:service.mne@barco.com), Web: [www.barco.com](http://www.barco.com)

From: \_\_\_\_\_

Date: \_\_\_\_\_

Please correct the following points in this documentation (**R59770180/04**):

**page**

**wrong**

**correct**